

This file is available for free download at <http://www.iluvmyrx7.com>

This file was not scanned to deprive Mazda of any money – it was scanned due to the rareness of the original manuals and the overwhelming need of the RX-7 owner to have this information so that they can accurately troubleshoot problems. Perhaps if Mazda's dealerships could support the Rotary Engine it wouldn't be so necessary for the owners to do so.



Many thanks to Anh Diep for scanning this file.

Before beginning any service procedure, refer to the 1993 RX-7 Body Electrical Troubleshooting Manual; see section S for air bag system precautions and J1 for audio anti-theft system precautions.

SUSPENSION

INDEX	R - 2
OUTLINE	R - 4
SPECIFICATIONS	R - 4
TROUBLESHOOTING GUIDE	R - 5
WHEEL ALIGNMENT	R - 6
PREINSPECTION	R - 6
FRONT WHEEL ALIGNMENT	R - 6
REAR WHEEL ALIGNMENT	R - 9
FRONT SUSPENSION (DOUBLE WISHBONE, COIL SPRING TYPE)	R -10
PREPARATION	R -10
FRONT SHOCK ABSORBER AND SPRING	R -12
UPPER ARM	R -16
FRONT LOWER ARM	R -19
FRONT STABILIZER	R -24
FRONT STRUT BAR	R -25
REAR SUSPENSION (DOUBLE WISHBONE, COIL SPRING TYPE)	R -26
PREPARATION	R -26
REAR SHOCK ABSORBER AND SPRING	R -27
UPPER ARM	R -32
REAR LOWER ARM	R -36
TOE-CONTROL LINK	R -40
REAR STABILIZER	R -42
REAR STRUT BAR	R -43

INDEX

FRONT SUSPENSION

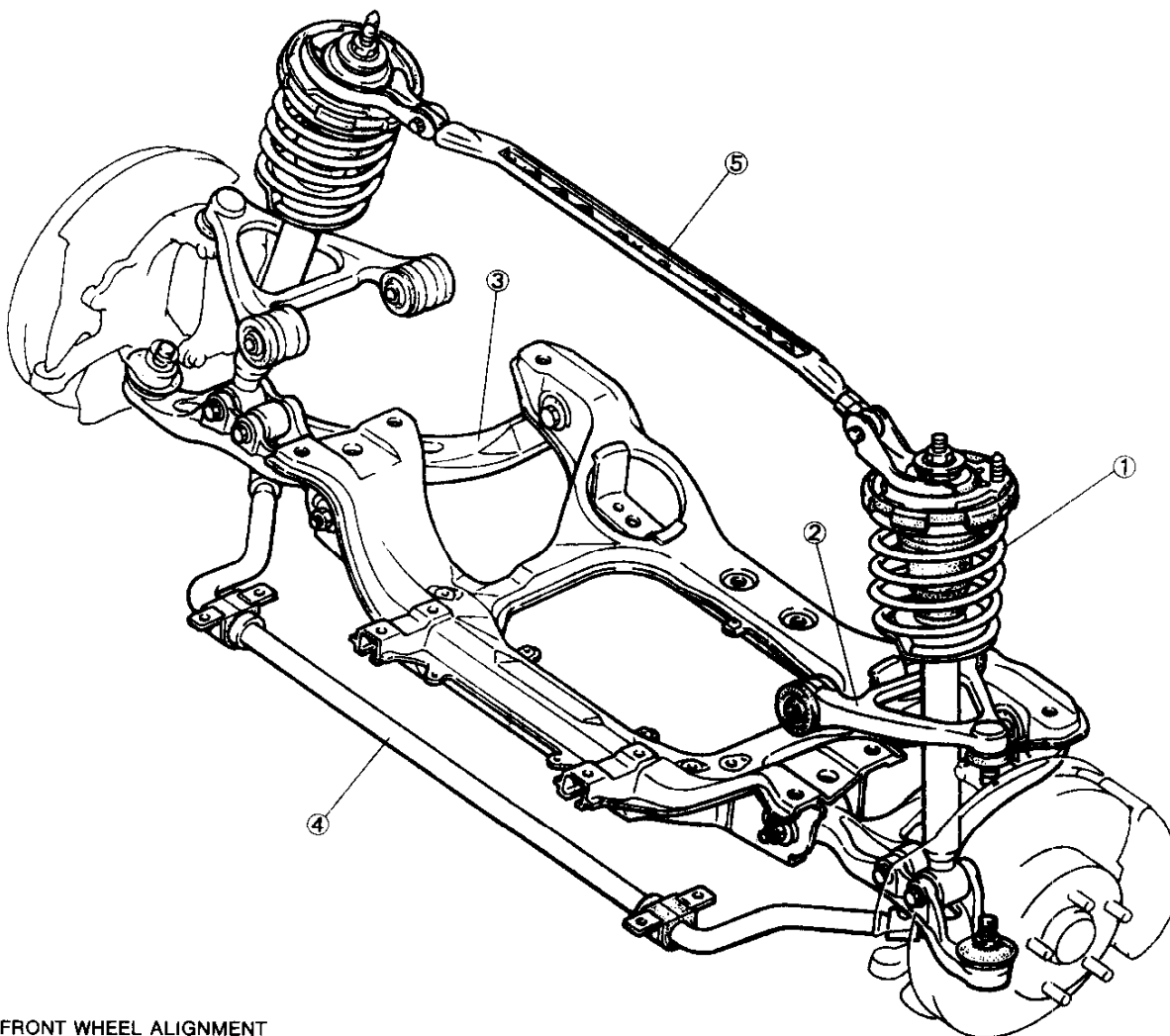

FRONT WHEEL ALIGNMENT

TOTAL TOE-IN: 1 ± 3 mm (0.04 \pm 0.11 in)

TOE-IN (PER SIDE): $0^{\circ}03' \pm 0.8'$

MAXIMUM STEERING ANGLE: $36^{\circ} \pm 2^{\circ}$ (INNER)
 $32^{\circ} \pm 2^{\circ}$ (OUTER)

CAMBER ANGLE: $0^{\circ}05' \pm 45'$

CASTER ANGLE: $6^{\circ}05' \pm 1^{\circ}$

KINGPIN ANGLE: $13^{\circ}55'$

37U0RX-002

- | | | |
|--|--|--|
| <p>1. Front shock absorber and spring
 Removal / Installation
 page R-12
 Disassembly / Inspection /
 Assembly page R-13</p> | <p>3. Front lower arm
 Removal / Inspection /
 Installation page R-19
 Inspection page R-20
 Disassembly / Inspection /
 Assembly page R-21</p> | <p>4. Front stabilizer
 Removal / Inspection /
 Installation page R-24</p> <p>5. Front strut bar
 Removal / Inspection /
 Installation page R-25</p> |
| <p>2. Upper arm
 Removal / Inspection /
 Installation page R-16
 Inspection page R-17
 Disassembly / Inspection /
 Assembly page R-17</p> | | |

REAR SUSPENSION

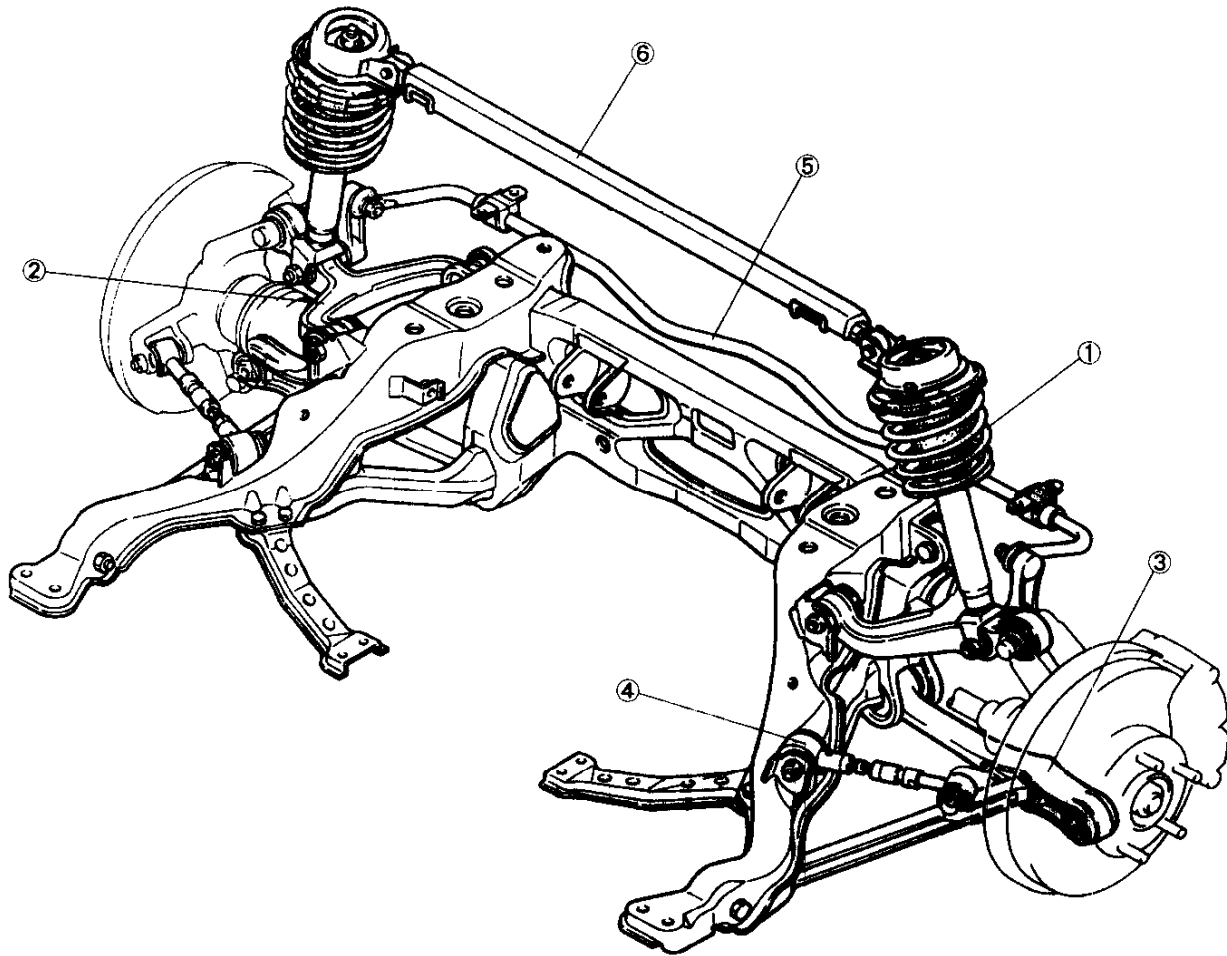

REAR WHEEL ALIGNMENT
 TOTAL TOE-IN: 2 ± 3 mm (0.08 ± 0.11 in);
 TOE-IN (PER SIDE): $0^{\circ}05' \pm 08'$
 CAMBER ANGLE: $-1^{\circ}13' \pm 45'$
 THRUST ANGLE: $0^{\circ} \pm 06'$

37U0RX-003

- 1. Rear shock absorber and spring
 Removal / Installation
 page R-27
 Disassembly / Inspection /
 Assembly ... page R-29
- 2. Upper arm
 Removal / Inspection
 Installation page R-32
 Disassembly / Inspection /
 Assembly page R-33

- 3. Rear lower arm
 Removal / Inspection
 Installation page R-36
 Disassembly / Inspection /
 Assembly page R-37
- 4. Toe-control link
 Removal / Inspection
 Installation page R-40

- 5. Rear stabilizer
 Removal / Inspection /
 Assembly page R-42
- 6. Rear strut bar
 Removal / Inspection /
 Assembly page R-43

OUTLINE

SPECIFICATIONS

Item	Grade		BASE, TOURING	R1	
Front suspension					
Suspension type			Double-wishbone		
Coil spring	Identification mark color		Blue		
	Wire diameter	mm {in}	12.4 {0.49}		
	Coil center diameter	mm {in}	104.9 {4.130}		
	Free length	mm {in}	272.9 {10.74}		
	Active coil number		4.27		
Shock absorber type			Cylindrical, double-acting, low-pressure gas charged		
Stabilizer	Type		Torsion bar, hollow type		
	Diameter	mm {in}	28.6 {1.13}		
Front wheel alignment (unladen*1)	Total toe-in		mm {in}		1 ± 3 {0.04 ± 0.11}
	Toe-in (per side)		degree		0°03' ± 08'
	Maximum steering angle	degree	Inner	36° ± 2°	
			Outer	32° ± 2°	
	Camber angle*2		degree		0°05' ± 45'
	Caster angle*2		degree		6°05' ± 1°
	Kingpin angle		degree		13°55'
Rear suspension					
Suspension type			Double-wishbone		
Coil spring	Identification mark color		White		
	Wire diameter	mm {in}	12.2 {0.48}		
	Coil center diameter	mm {in}	114.7 {4.516}		
	Free length	mm {in}	299.0 {11.77}		
	Active coil number		4.21		
Shock absorber type			Cylindrical, double-acting, low-pressure gas charged		
Stabilizer	Type		Torsion bar, hollow type		
	Diameter	mm {in}	17.3 {0.68}		
Rear wheel alignment (unladen*1)	Total toe-in		mm {in}		2 ± 3 {0.08 ± 0.11}
	Toe-in (per side)		degree		0°05' ± 08'
	Camber angle*2		degree		- 1°13' ± 45'
	Thrust angle		degree		0° ± 06'

37UORX-0/4

*1 Fuel tank full; radiator coolant and engine oil at specified levels; spare tire, jack, and tools in designated positions.

*2 Difference between left and right must not exceed 1°.

TROUBLESHOOTING GUIDE

Problem	Possible cause	Action	Page
Body rolls	Weak stabilizer or stabilizer link	Replace	R-24, 42
	Damaged or worn stabilizer control link	Replace	R-24, 42
	Worn or deteriorated upper arm or lower arm bushings	Replace	R-17, 21, 33, 37
	Damaged shock absorber	Replace	R-12, 27
Poor riding comfort	Weak coil spring	Replace	R-13, 29
	Damaged shock absorber	Replace	R-12, 27
Body leans	Weak coil spring	Replace	R-13, 29
	Damaged or worn stabilizer control link	Replace	R-24, 42
	Worn or deteriorated upper arm or lower arm bushings	Replace	R-17, 21, 33, 37
Abnormal noise from suspension system	Poor lubrication of or worn upper arm or lower arm ball joint	Lubricate or replace	R-17, 21
	Looseness of peripheral connections	Tighten	-
	Damaged shock absorber	Replace	R-12, 27
	Damaged or worn stabilizer control link	Replace	R-24, 42
	Worn or deteriorated upper arm or lower arm bushings	Replace	R-17, 21, 33, 37
General driving instability	Weak coil spring	Replace	R-13, 29
	Damaged shock absorber	Replace	R-12, 27
	Worn or deteriorated upper arm or lower arm bushings	Replace	R-17, 21, 33, 37
	Damaged or worn stabilizer control link	Replace	R-24, 42
	Improperly adjusted wheel alignment	Adjust	R-6
	Damaged or worn upper arm or lower arm ball joint	Replace	R-17, 21
	Malfunction of steering system	-	Section N
Damaged or unbalanced wheel	-	Section Q	
Heavy steering	Poor lubrication of or worn upper arm or lower arm ball joint	Lubricate or replace	R-17, 21
	Improperly adjusted wheel alignment	Adjust	R-6
	Malfunction of steering system	-	Section N
	Damaged or unbalanced wheel	-	Section Q
Steering wheel pulls to one side	Weak coil spring	Replace	R-13, 29
	Damaged or worn stabilizer control link	Replace	R-24, 42
	Worn or deteriorated upper arm or lower arm bushings	Replace	R-17, 21, 33, 37
	Damaged or worn upper arm or lower arm	Replace	R-17, 21, 33, 37
	Improperly adjusted wheel alignment	Adjust	R-6
	Malfunction of steering system	-	Section N
	Malfunction of braking system	-	Section P
Damaged or unbalanced wheel	-	Section Q	
Shimmy occurs (steering wheel vibrates circumferential)	Damaged or worn upper arm or lower arm ball joint	Replace	R-17, 21
	Damaged shock absorber	Replace	R-12
	Loose shock absorber mounting	Tighten	R-12
	Worn or deteriorated upper arm or lower arm bushings	Replace	R-17, 21
	Damaged or worn stabilizer control link	Replace	R-24
	Improperly adjusted wheel alignment	Adjust	R-6
	Damaged or worn wheel bearing	-	Section M
Malfunction of steering system	-	Section N	
Damaged or unbalanced wheel	-	Section Q	
Steering wheel doesn't return properly	Stuck or damaged upper arm or lower arm ball joint	Replace	R-17, 21
	Improperly adjusted wheel alignment	Adjust	R-6
	Malfunction of steering system	-	Section N
	Damaged or unbalanced wheel	-	Section Q

37U0RX-005

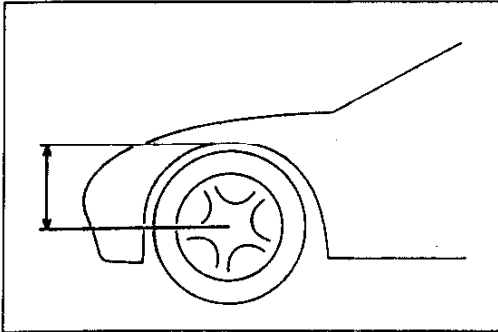

37U0RX-006

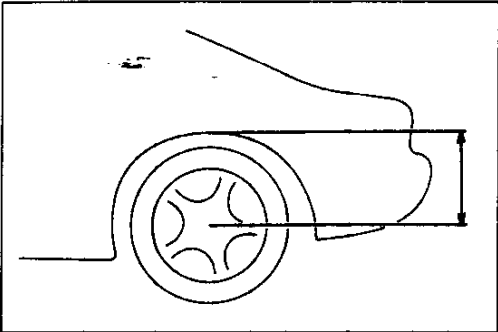

37U0RX-007

WHEEL ALIGNMENT

PREINSPECTION

1. Check the tire inflations and set to the recommended pressure, if necessary.
2. Inspect the front wheel bearing play. Replace the bearing(s) as necessary.
3. Inspect the wheel and tire runout of all wheels.
4. Inspect the ball joints and steering linkage for excessive looseness.
5. Place the vehicle on level ground with no luggage or passenger load.
6. Rock the vehicle to settle the suspension.
7. Verify that the height difference between the left and right sides from the center of the wheel to the fender brim does not exceed specification.

Specification: 10 mm {0.39 in}

8. Verify that the height difference between the front and rear does not exceed specifications.

Specification: 15 mm {0.59 in}

FRONT WHEEL ALIGNMENT

Specifications (Unladen*¹)

Item		Specifications
Total toe-in	mm {in}	1 ± 3 {0.04 ± 0.11}
Toe-in (per side)	Degree	0°03' ± 08'
Maximum steering angle	In	36° ± 2°
	Out	32° ± 2°
Kingpin angle		13°55'
Camber angle* ²	Degree	0°05' ± 45'
Caster angle* ²	Degree	6°05' ± 1°

37U0RX-008

*¹ Fuel tank full; radiator coolant and engine oil at specified levels; spare tire, jack, and tools in designated positions.

*² Difference between left and right must not exceed 1°.

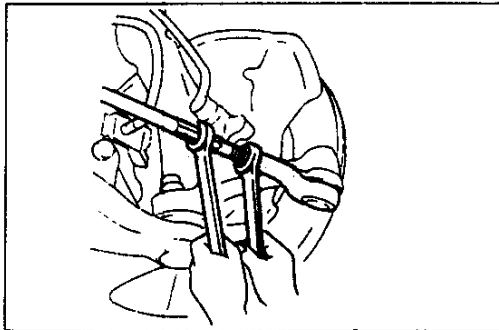

37U0RX-009

Adjustment

Toe-in

1. Remove the steering gear boot clamp.
2. Loosen the tie rod locknut.

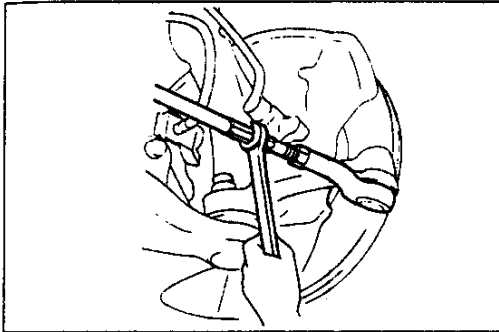

37U0RX-010

- Turn each of the tie rods the same amount.

Caution

- To increase the toe-in, turn the right tie rod toward the front of the vehicle and the left one the same amount toward the rear.
- One turn of the tie rod (one side) changes the toe-in about 10.6 mm {0.42 in}.
- Adjust the toe-in after adjusting the steering angle.

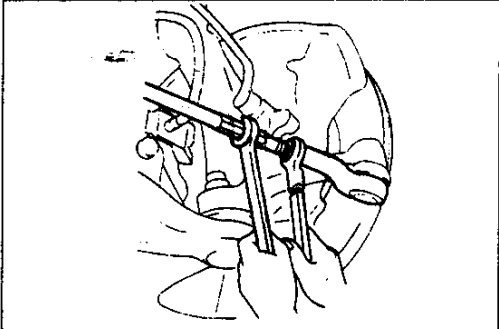

37U0RX-011

- Tighten the tie rod locknuts to the specified torque.

Tightening torque:

31–50 N·m {3.1–5.1 kgf·m, 23–36 ft·lbf}

- Verify that the boot is not twisted. Install the boot clamp.

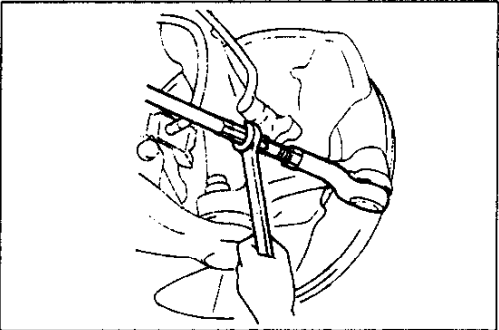

29U0RX-010

Maximum steering angle

- Remove the steering gear boot clamp.
- Loosen the tie rod locknut.
- Turn the tie rod to provide the correct maximum steering angle.

Maximum left / right difference: 3 mm {0.12 in}

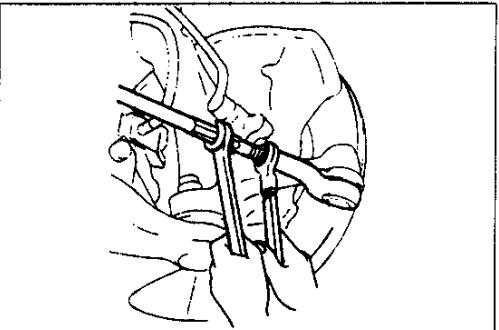

37U0RX-012

- After adjustment, tighten the locknut to the specified torque.

Tightening torque:

31–50 N·m {3.1–5.1 kgf·m, 23–36 ft·lbf}

- Adjust the toe-in. (Refer to page R-6.)
- Verify that the boot is not twisted. Install the boot clamp.

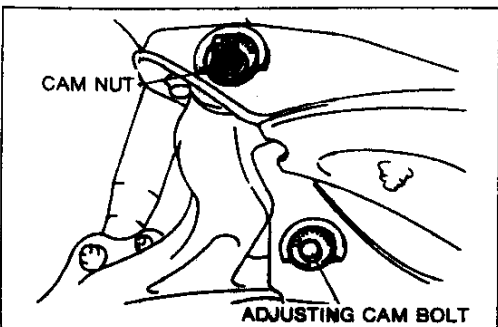

37U0RX-013

Caster

Caution

- Adjust the caster before adjusting the camber.

R

WHEEL ALIGNMENT

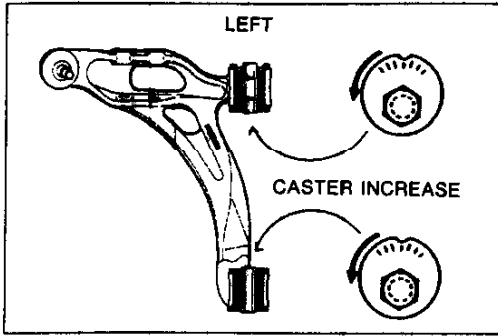

37U0RX-014

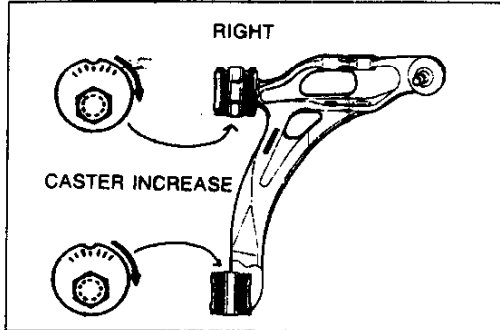

37U0RX-015

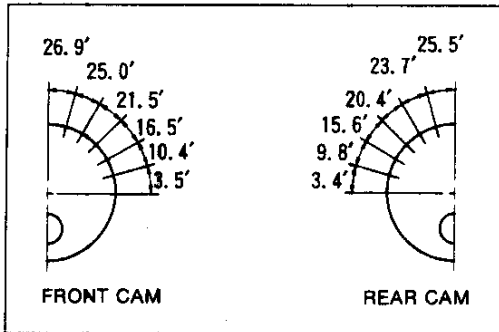

37U0RX-102

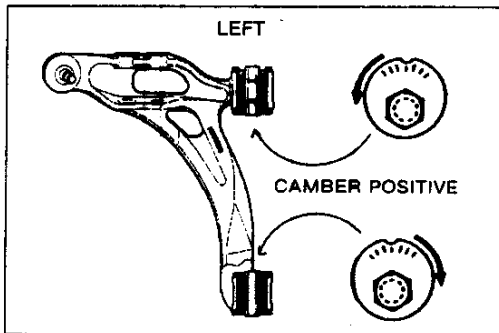

37U0RX-016

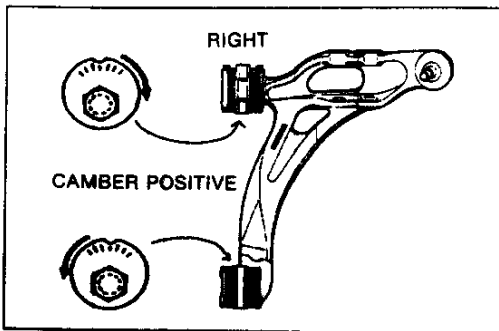

37U0RX-017

1. Loosen the front and / or rear cam nut on the front lower arm.
2. Turn the adjusting cam bolt as indicated to provide the correct caster angle.

Caster	Left wheel		Right wheel	
	Front cam	Rear cam	Front cam	Rear cam
Increase	Counter-clockwise	Counter-clockwise	Clockwise	Clockwise
Decrease	Clockwise	Clockwise	Counter-clockwise	Counter-clockwise

3. Adjust the camber and the toe-in.

Note

- Turning the adjusting cam bolt one graduation changes the caster as shown in the illustration.

Camber

Caution

- Adjust the camber after adjusting the caster.

1. Loosen the front and / or rear cam nut on the front lower arm.
2. Turn the adjusting cam bolt as indicated to provide the correct camber angle.

Camber	Left wheel		Right wheel	
	Front cam	Rear cam	Front cam	Rear cam
Positive	Counter-clockwise	Clockwise	Clockwise	Counter-clockwise
Negative	Clockwise	Counter-clockwise	Counter-clockwise	Clockwise

Note

- If the cam cannot be turned enough to make the adjustment, begin again at adjustment of the caster using the other cam.

WHEEL ALIGNMENT

R

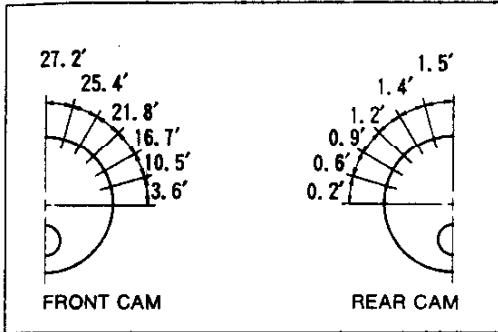

37UORX-103

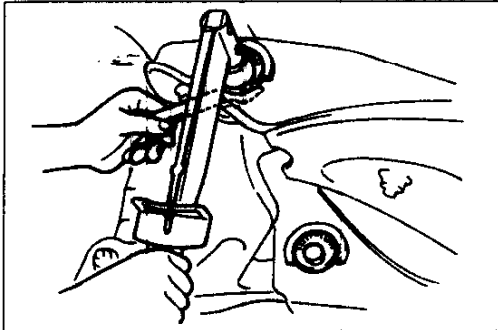

37UORX-018

Note

- Turning the adjusting cam bolt one graduation changes the camber as shown in the illustration.

3. Tighten the cam nut to the specified torque.

Tightening torque:

94-116 N·m {9.5-11.9 kgf·m, 69-86 ft·lbf}

Caution

- Loosely tighten the rear cam nut. Then lower the vehicle and tighten it to the specified torque with the vehicle unladen.

4. Adjust the toe-in.

REAR WHEEL ALIGNMENT

Specifications (Unladen¹)

Item		Specifications
Total toe-in	mm {in}	2 ± 3 {0.08 ± 0.11}
Toe-in (per side)	Degree	0°05' ± 08'
Camber angle ²	Degree	-1°13' ± 45'
Thrust angle	Degree	0° ± 06'

37UORX-019

¹ Fuel tank full; radiator coolant and engine oil at specified levels; spare tire, jack, and tools in designated positions.

² Difference between left and right must not exceed 1°.

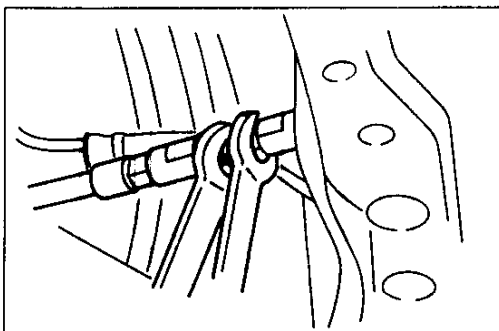

37UORX-020

Adjustment

Toe-in

Note

- The rear toe-in setting must be adjusted while maintaining a thrust angle within specified limits.

Thrust angle: 0° ± 06'

- If the thrust angle is not within specification, check the body dimensions.

Refer to 1992 RX-7 Body Shop Manual (Form No. 3256-10-92A)

R WHEEL ALIGNMENT, FRONT SUSPENSION (DOUBLE WISHBONE, COIL SPRING TYPE)

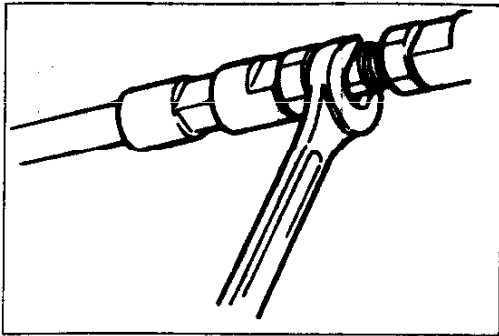

37U0RX-021

1. Loosen the left and right toe control link locknuts, and turn each of the links the same amount.

Caution

- To increase the toe-in, turn the right link toward the front of the vehicle, and turn the left link by the same amount toward the rear.
- One turn of the link (one side) changes the toe-in by about 16.5 mm (0.65 in).

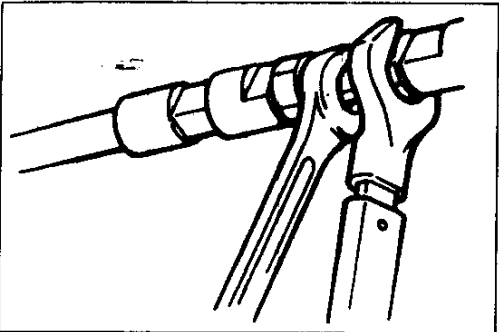

37U0RX-097

2. Tighten the toe control link locknuts to the specified torque.

Tightening torque:

55–63 N·m (5.6–6.5 kgf·m, 41–47 ft·lbf)

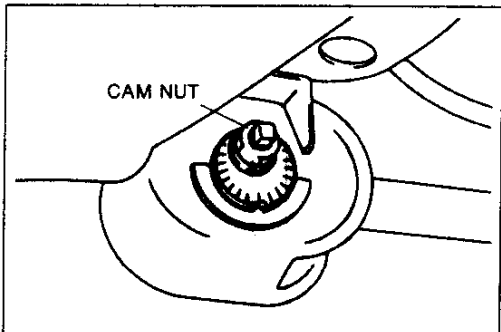

37U0RX-022

Camber

1. Loosen the cam nut on the I-arm.
2. Turn the adjusting cam bolt as indicated to provide the correct camber angle.

Camber	Left wheel	Right wheel
Positive	Clockwise	Counterclockwise
Negative	Counterclockwise	Clockwise

Note

- Turning the adjusting cam bolt one graduation changes the camber as shown in the illustration.

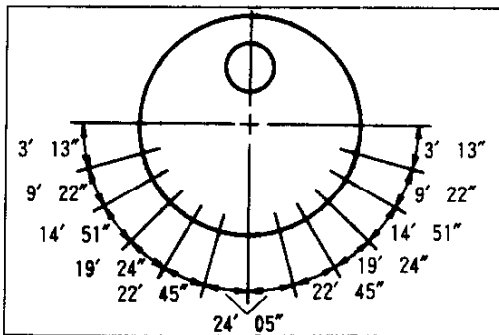

3. Tighten the cam nut to the specified torque.

Tightening torque:

94–116 N·m (9.5–11.9 kgf·m, 69–86 ft·lbf)

4. Adjust the toe-in.

FRONT SUSPENSION (DOUBLE WISHBONE, COIL SPRING TYPE)





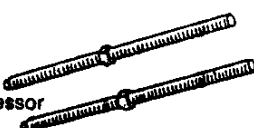
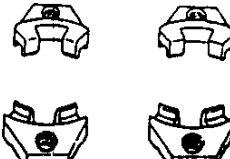



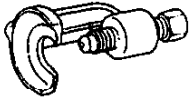

PREPARATION

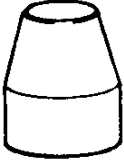
SST

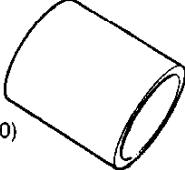
<p>49 0370 641</p> <p>Screw, coil spring compressor</p> 	<p>For removal / installation of coil spring</p>	<p>49 0223 640B</p> <p>Arm, coil spring compressor</p> 	<p>For removal / installation of coil spring</p>
---	--	---	--

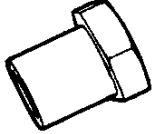
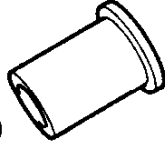
FRONT SUSPENSION (DOUBLE WISHBONE, COIL SPRING TYPE)

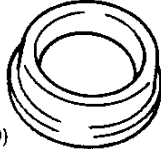
R

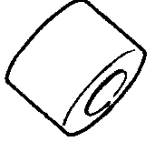
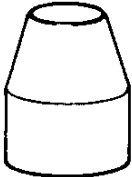
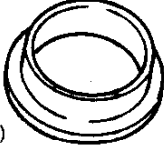
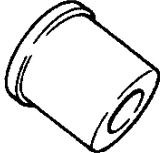
<p>49 0118 850C Puller, ball joint</p> 	<p>For removal of ball joint</p>	<p>49 0180 510B Attachment, preload measuring</p> 	<p>For inspection of ball joint</p>
<p>49 F034 211 Guide, clip</p> 	<p>For installation of dust boot clip</p>	<p>49 F034 2A0 Replacer set, rubber bushing</p> 	<p>For removal / installation of bushing</p>
<p>49 G028 203 Support (Part of 49 F034 2A0)</p> 	<p>For removal of bushing</p>	<p>49 G028 206 Shaft (Part of 49 F034 2A0)</p> 	<p>For removal / installation of bushing</p>
<p>49 G028 207 Nut (Part of 49 F034 2A0)</p> 	<p>For removal / installation of bushing</p>	<p>49 G028 208 Installer (Part of 49 F034 2A0)</p> 	<p>For removal of bushing</p>
<p>49 G034 205 Bearing (Part of 49 F034 2A0)</p> 	<p>For removal / installation of bushing</p>	<p>49 F034 204 Support (Part of 49 F034 2A0)</p> 	<p>For removal of bushing</p>
<p>49 F034 203 Support (Part of 49 F034 2A0)</p> 	<p>For installation of bushing</p>	<p>49 F034 206 Shaft (Part of 49 F034 2A0)</p> 	<p>For installation of bushing</p>
<p>49 F034 209 Installer (Part of 49 F034 2A0)</p> 	<p>For removal / installation of bushing</p>	<p>49 F034 210 Guide, clip</p> 	<p>For installation of dust boot clip</p>
<p>49 F034 205 Support (Part of 49 F034 2A0)</p> 	<p>For removal / installation of bushing</p>	<p>49 F034 208 Installer (Part of 49 F034 2A0)</p> 	<p>For installation of bushing</p>

37U0RX-024

R FRONT SUSPENSION (DOUBLE WISHBONE, COIL SPRING TYPE)

FRONT SHOCK ABSORBER AND SPRING

Removal / Installation

1. Jack up the front of the vehicle and support it on safety stands.
2. Remove the wheel and tire.
3. Remove in the order shown in the figure.
4. Install in the reverse order of removal, referring to **Installation Note**.
5. Install the wheel and tire.

Tightening torque: 89–117 N·m {9.0–12.0 kgf·m, 65–87 ft·lbf}

6. Adjust the front wheel alignment. (Refer to page R-6.)

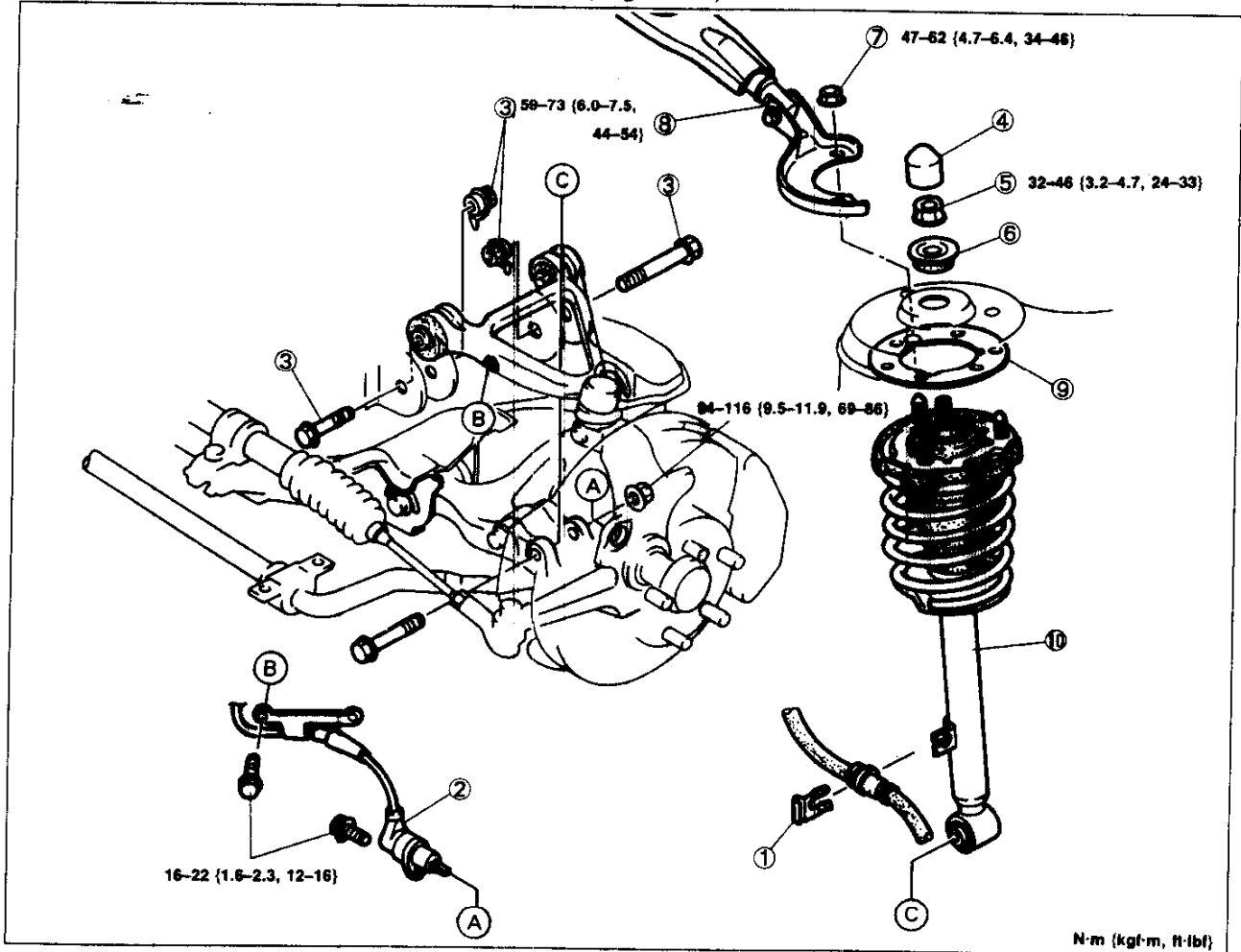

N·m (kgf·m, ft·lbf)

37U0RX-025

- | | | |
|---------------------------|---------------------------------|-------------------------------------|
| 1. Clip (brake hose) | 7. Nut | 10. Front shock absorber and spring |
| 2. ABS wheel-speed sensor | 8. Front strut bar (R1 vehicle) | Installation Note |
| 3. Bolt, nut | Removal / Inspection / | page R-13 |
| 4. Cap | Installation | Disassembly / Inspection / |
| 5. Nut | page R-25 | Assembly page R-13 |
| 6. Stopper rubber | 9. Insulator | |

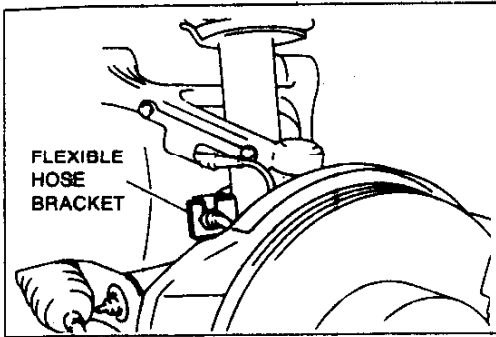

37U0RX-026

Installation note

Front shock absorber and spring

Install the shock absorber and spring so that the flexible hose bracket faces forward.

Disassembly / Inspection / Assembly

1. Disassemble in the order shown in the figure, referring to **Disassembly Note**.
2. Inspect all parts and repair or replace as necessary.
3. Assemble in the reverse order of removal, referring to **Assembly Note**.

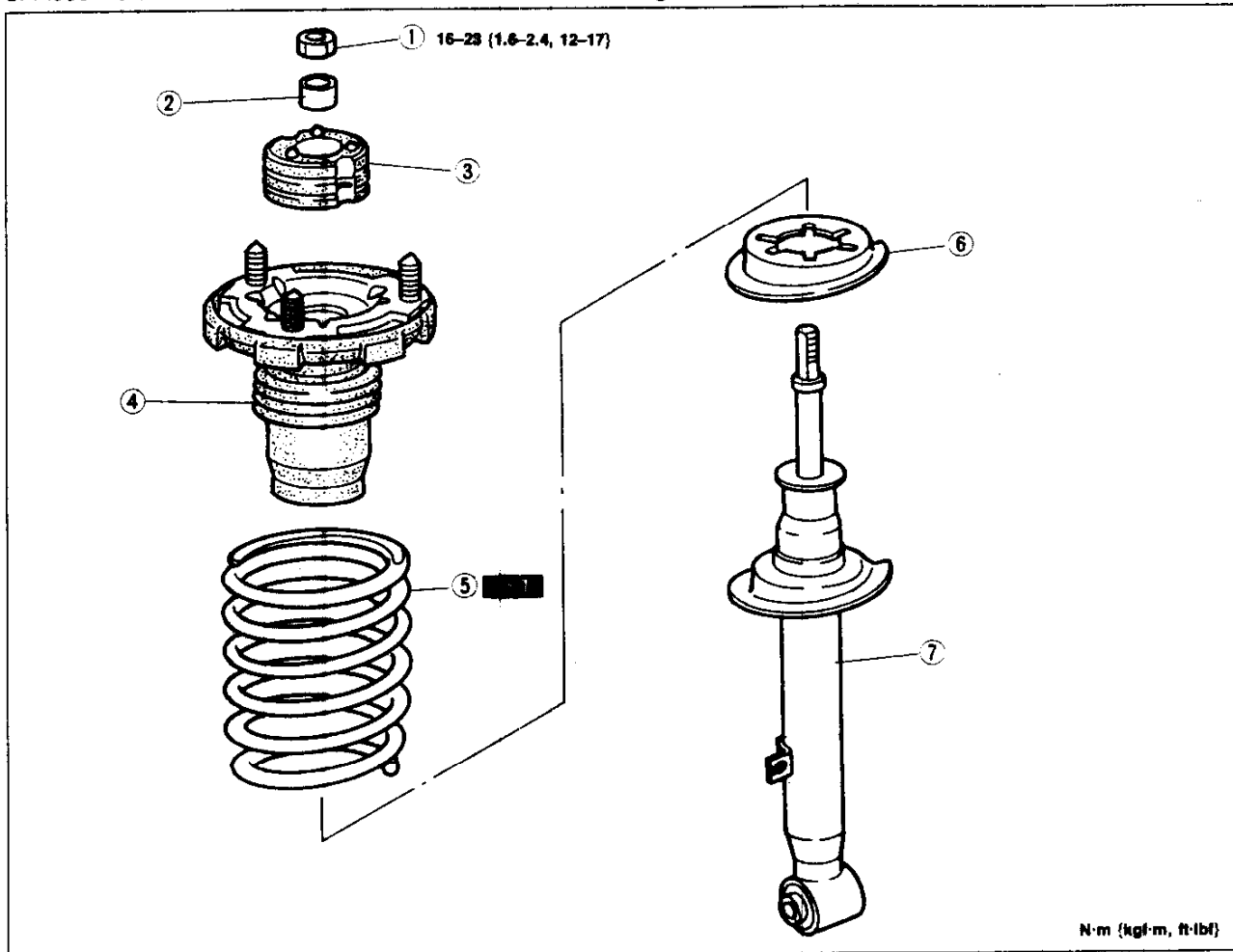

N·m (kgf·m, ft·lbf)

37U0RX-027

1. Nut
Disassembly Note page R-14
Assembly Note page R-15
2. Spacer
3. Mounting rubber
Inspect for damage and deterioration
Assembly Note page R-15

4. Bound stopper assembly
Inspect for damage and cracks
5. Coil spring
Inspect for damage and weakness
Assembly Note page R-14

6. Lower spring seat
Inspect for damage and cracks
7. Shock absorber
Inspection page R-14

R FRONT SUSPENSION (DOUBLE WISHBONE, COIL SPRING TYPE)

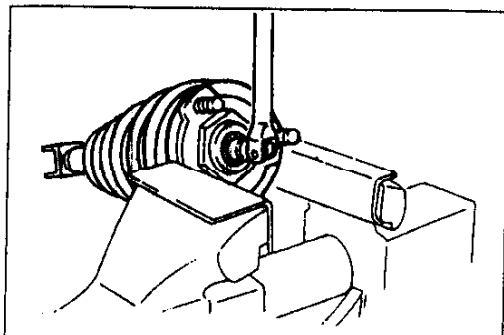

37U0RX-098

Disassembly note Nut

Caution

- Use protective plates in the jaws of the vise to prevent damage to the bracket.

1. Secure the mounting rubber bracket in a vise.

Warning

- Because the coil spring is under considerable tension, do not remove the mounting rubber nut before installation of the SST.

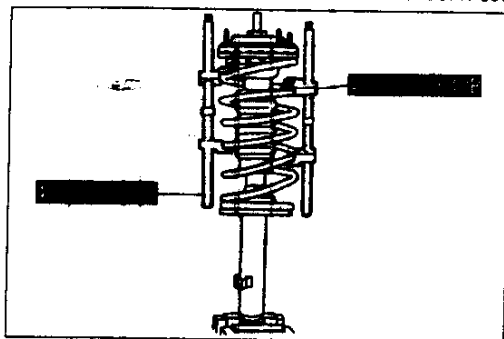

2. Loosen the mounting rubber nut several turns, but do not remove it.
3. Assemble the SST.
4. Compress the coil spring by using the SST and remove the mounting nut.

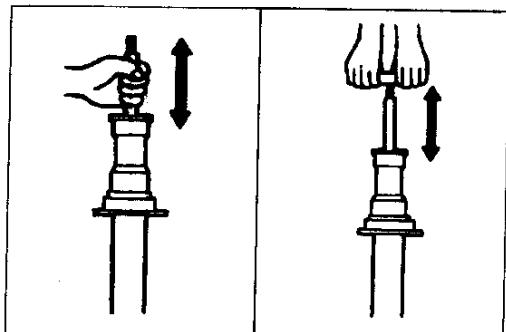

37U0RX-099

Inspection

Shock absorber

Check the following and replace the shock absorber if necessary.

1. Inspect for damage and oil leakage.
2. (1) Compress the shock absorber rod and release it.
(2) Verify that the rod extends fully at a normal speed.
3. Compress and extend the rod at least three times. Verify that the operational force does not change and that there is no unusual noise.

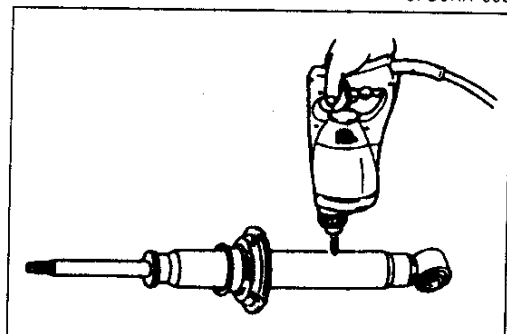

29U0RX-100

Disposal of shock absorber

Caution

- The gas in the shock absorber is colorless, odorless, and nontoxic.
- Wear safety glasses because drilling chips may be blown out by the pressurized gas.

1. Lay the shock absorber flat.
2. Drill a hole in its body.

Drill size: 2-3 mm {0.08-0.12 in}

3. Allow the gas to escape from the shock absorber.
4. Discard the shock absorber.

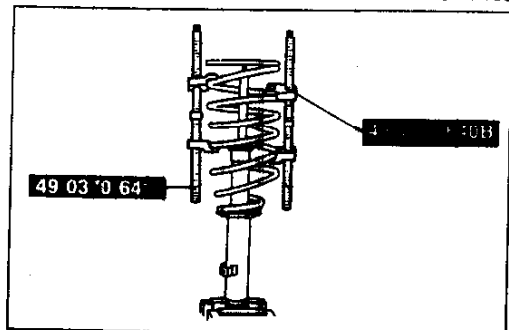

29U0RX-028

Assembly note

Coil spring

1. Compress the coil spring by using the SST.
2. Install the spring so that the lower coil is seated on the step of the lower seat.

FRONT SUSPENSION (DOUBLE WISHBONE, COIL SPRING TYPE)

R

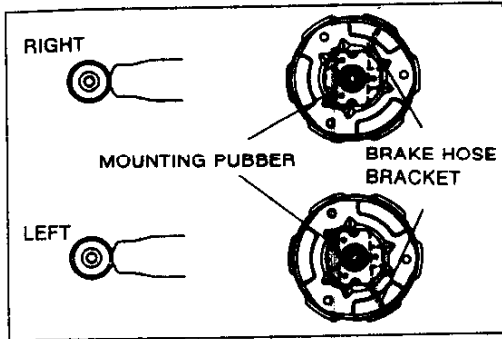

37U0RX-029

Mounting rubber

Install the mounting rubber as shown.

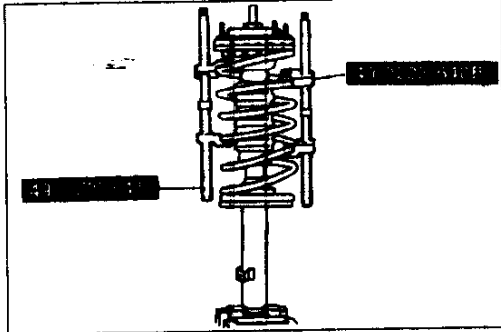

37U0RX-101

Nut

1. Tighten the mounting nut several turns.
2. Remove the SST.

Caution

- Verify that the lower coil of the spring is seated on the step of the lower seat.

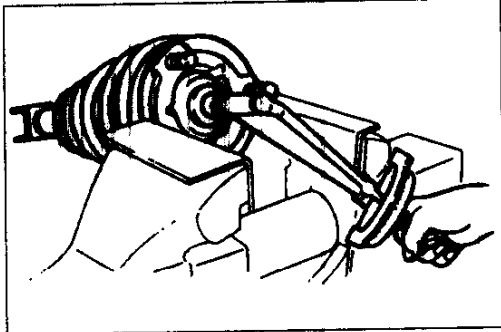

37U0RX-030

3. Secure the mounting rubber bracket in a vise.
4. Tighten the nut.

Tightening torque:

16-23 N·m {1.6-2.4 kgf-m, 12-17 ft-lbf}

R FRONT SUSPENSION (DOUBLE WISHBONE, COIL SPRING TYPE)

UPPER ARM

Removal / Inspection / Installation

1. Jack up the front of the vehicle and support it on safety stands.
2. Remove the wheel and tire.
3. Remove in the order shown in the figure.
4. Inspect all parts and repair or replace as necessary.
5. Install in the reverse order of removal.
6. Install the wheel and tire.

Tightening torque: 89–117 N·m {9.0–12.0 kgf·m, 65–87ft·lbf}

7. Adjust the front wheel alignment. (Refer to page R-6.)

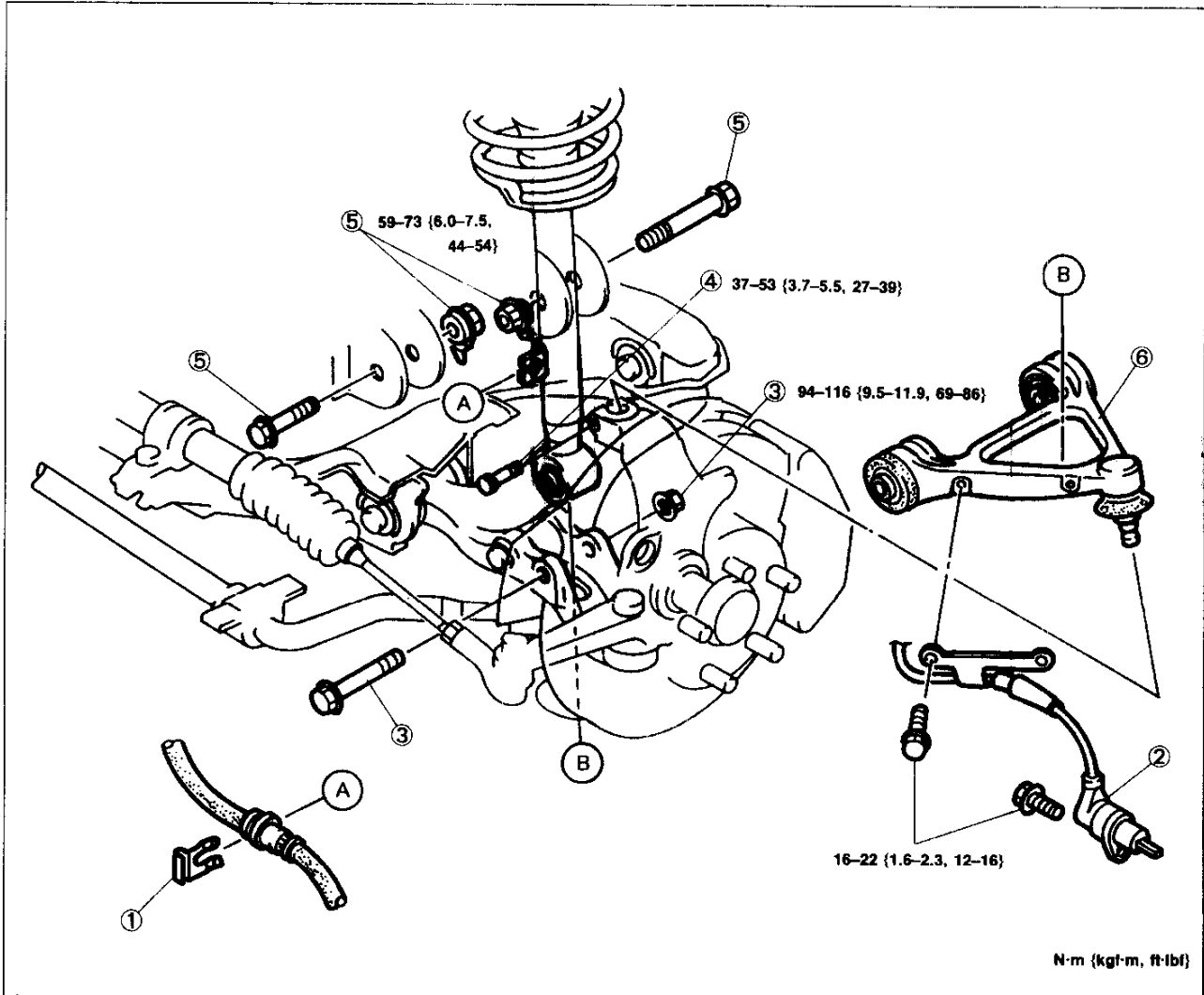

1. Clip (brake hose)
2. ABS wheel-speed sensor

3. Bolt nut
4. Bolt
5. Bolt nut

6. Upper arm
 Inspect for damage and cracks
 Inspect bushing for damage and wear
 Inspect boot for tearing and cracks
 Inspection page R-17
 Disassembly / Inspection /
 Assembly page R-17

37U0RX-031

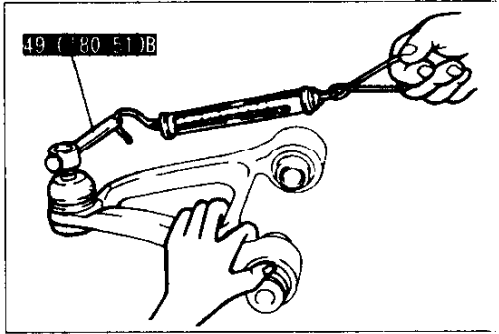

37U0RX-021

Inspection

Upper arm ball joint

Ball joint rotation torque

1. Shake and rotate the ball joint stud several times.
2. Connect the **SST** to the stud and measure the starting torque and the rotation torque by using a pull scale.

Starting torque:

2.0–5.8 N·m {20–60 kgf·cm, 18–52 in·lbf}

Pull scale reading:

20–58 N {2.0–6.0 kgf, 4.4–13.2 lbf}

Rotation torque:

0.4–1.1 N·m {4–12 kgf·cm, 3.5–10.4 in·lbf}

Pull scale reading:

4–11 N {0.4–1.2 kgf, 0.9–2.6 lbf}

3. If not within specification, replace the upper arm.

Disassembly / Inspection / Assembly

1. Disassemble in the order shown in the figure, referring to **Disassembly Note**.
2. Inspect all parts and repair or replace as necessary.
3. Assemble in the reverse order of disassembly, referring to **Assembly Note**.

Caution

- When holding a part in a vise, use protective plates in the jaws to prevent damage to the part.

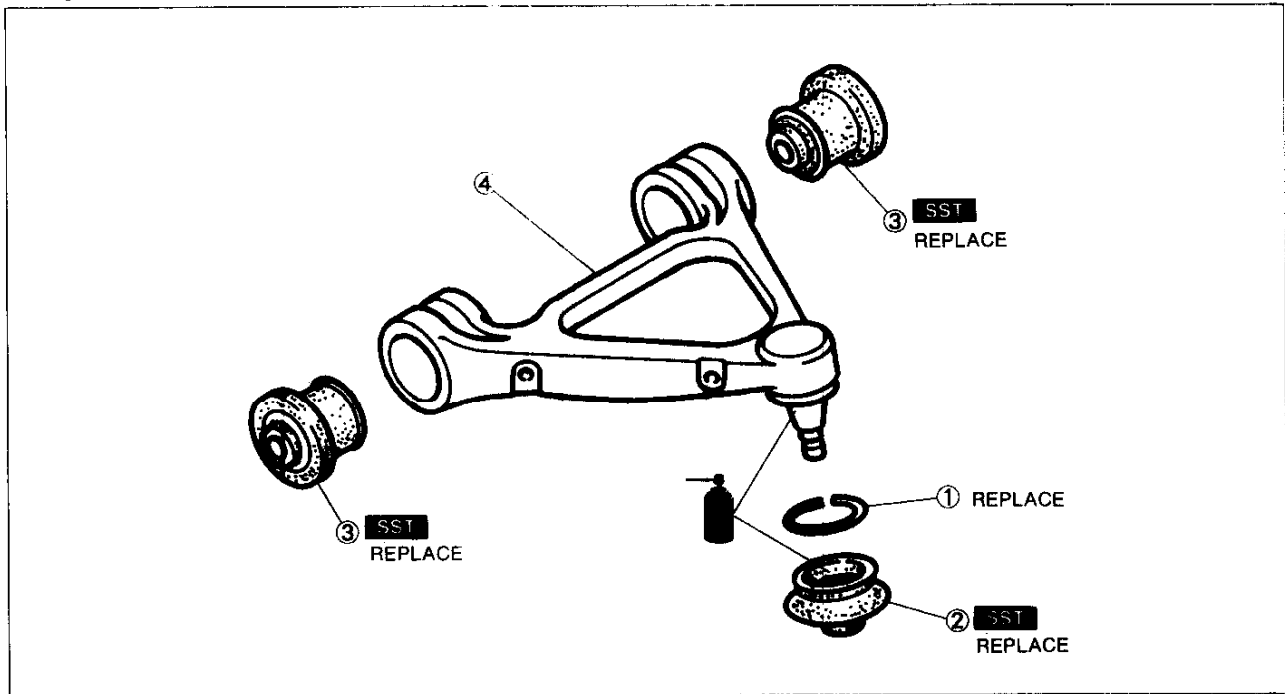

37U0RX-034

- | | |
|----------------------------------|-------------------------------|
| 1. Clip | 4. Upper arm |
| 2. Dust boot | Inspect for damage and cracks |
| Assembly Note page R-18 | |
| 3. Bushing | |
| Disassembly Note page R-18 | |
| Assembly Note page R-18 | |

R FRONT SUSPENSION (DOUBLE WISHBONE, COIL SPRING TYPE)

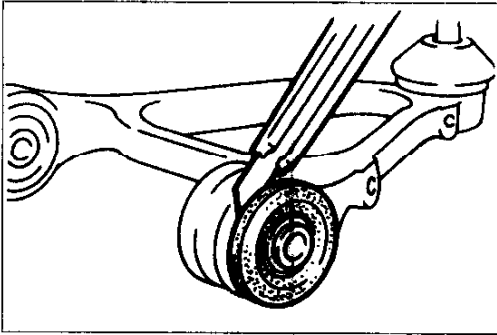

37U0RX-035

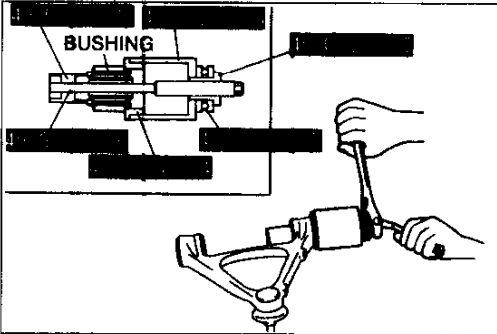

37U0RX-036

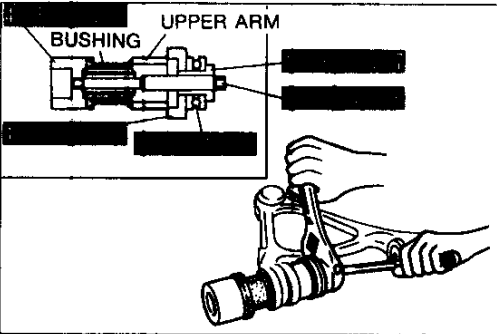

37U0RX-085

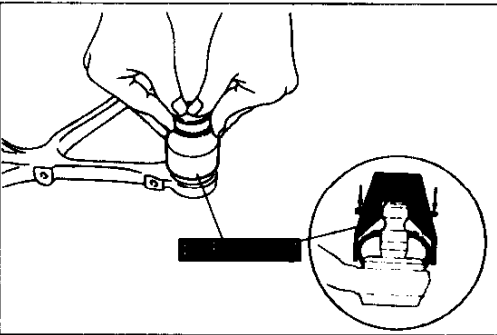

37U0RX-086

Disassembly note Bushings

1. Cut away the projecting rubber of the bushing.
2. Remove the bushing by using the **SST**.

Assembly note Bushings

1. Apply soapy water to the new bushing.
2. Install the bushing by using the **SST**.

Dust boot

1. Wipe the grease off the ball stud.
2. Fill the inside the new dust boot with grease.
3. Install the dust boot onto the ball joint.
4. Set the **SST** over the boot and install a new clip.
5. Wipe off the excess grease.

FRONT LOWER ARM

Removal / Inspection / Installation

1. Jack up the front of the vehicle and support it on safety stands.
2. Remove the wheel and tire.
3. Remove in the order shown in the figure, referring to **Removal Note**.
4. Inspect all parts and repair or replace as necessary.
5. Install in the reverse order of removal, referring to **Installation Note**.
6. Install the wheel and tire.

Tightening torque: 89–117 N·m {9.0–12.0 kgf·m, 65–87 ft·lbf}

Note

- Loosely tighten the rear cam nut of the lower arm. Lower the vehicle and tighten the nut to the specified torque with the vehicle unladen.

Tightening torque: 94–116 N·m {9.5–11.9 kgf·m, 69–86 ft·lbf}

7. Adjust the front wheel alignment. (Refer to page R-6.)

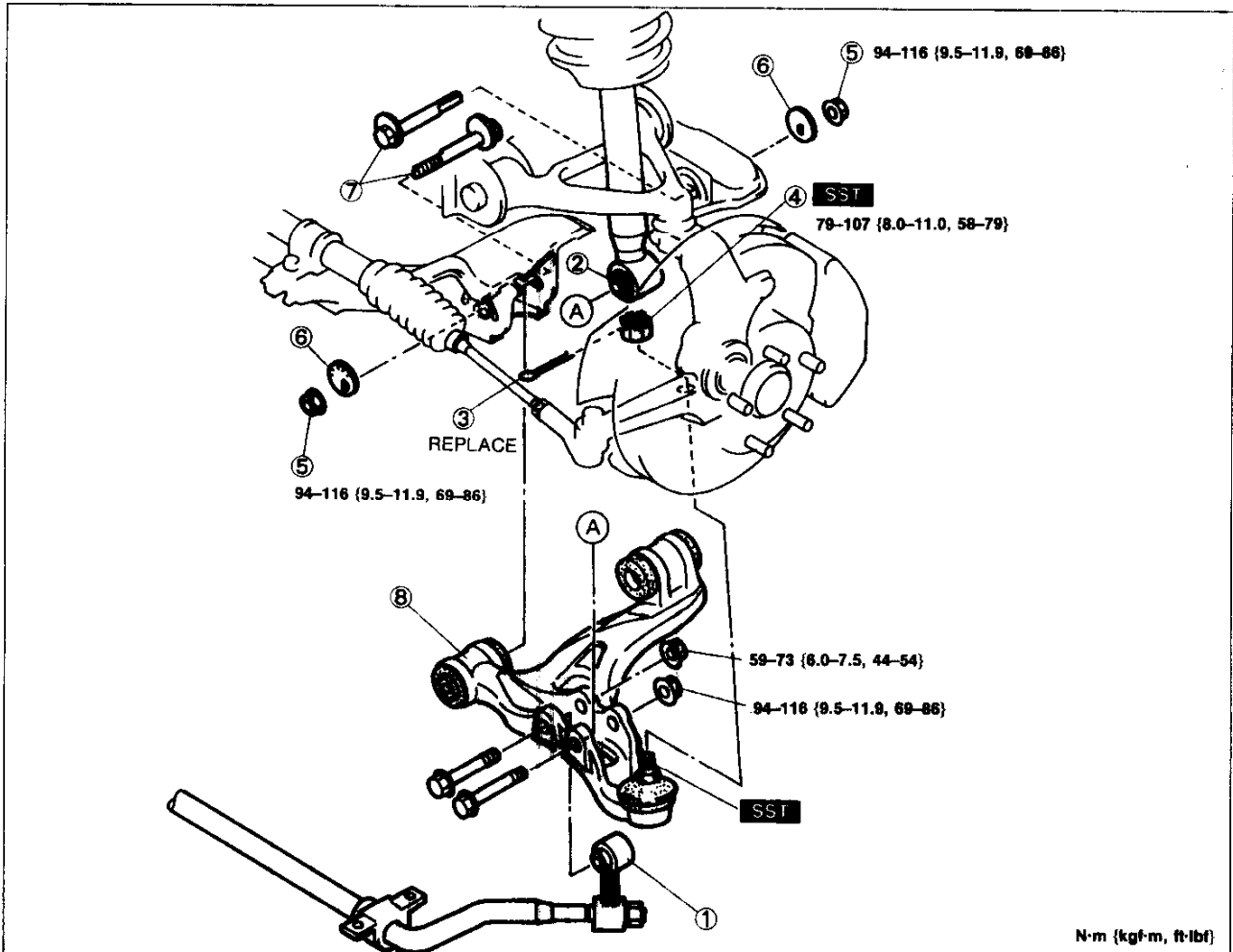

1. Front stabilizer control link
 2. Shock absorber and spring
 3. Cotter pin
 4. Nut
 5. Nut
 Removal Note page R-20
 Installation Note page R-20

6. Cam plate
 Removal Note page R-20
 Installation Note page R-20
 7. Adjusting cam bolt
 Installation Note page R-20

8. Front lower arm
 Removal Note ... page R-20
 Inspect for damage and cracks
 Inspect bushing for damage and wear
 Inspect boot for tearing and cracks
 Inspection page R-20
 Disassembly / Inspection / Assembly page R-21

37U0RX-037

R FRONT SUSPENSION (DOUBLE WISHBONE, COIL SPRING TYPE)

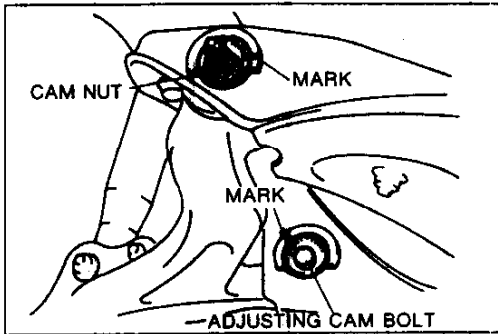

Removal note

Nut and cam plate

Before loosening the nut, make a mark on the cam plate and the crossmember for reference during installation.

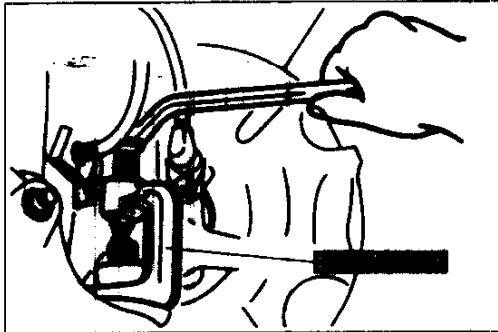

Front lower arm

1. Loosen the nut until it is flush with the end of the stud.
2. With the nut protecting the ball joint stud, separate the ball joint from the knuckle by using the **SST**.

Caution

- Do not damage the dust boot.

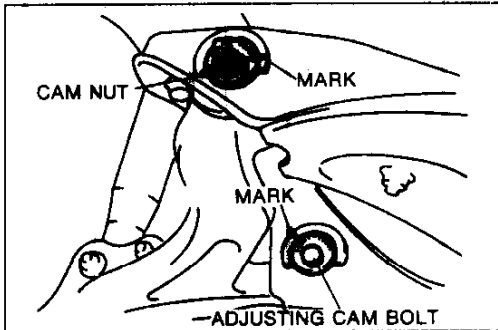

Installation note

Nut, cam plate, and adjusting cam bolt

1. Install the cam plate so that the notch faces the same direction as the adjusting cam bolt.
2. Align the mark made before removing the adjusting cam bolt. Temporarily tighten the nut.

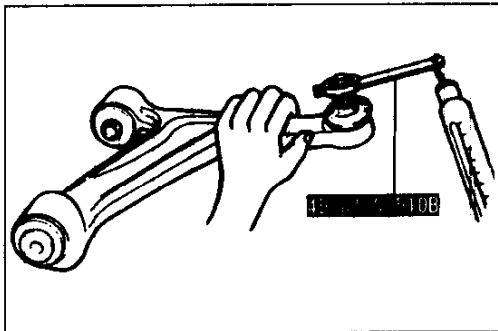

Inspection

Front lower arm ball joint

Ball joint rotation torque

1. Shake and rotate the ball joint stud at least five times.
2. Connect the **SST** to the stud and measure the starting torque and the rotation torque by using a pull scale.

Starting torque:

2.5–7.3 N·m {25–75 kgf·cm, 22–65 in·lbf}

Pull scale reading:

25–73 N {2.5–7.5 kgf, 5.5–16.5 lbf}

Rotation torque:

0.5–1.4 N·m {5–15 kgf·cm, 4.4–13.0 in·lbf}

Pull scale reading:

5–14 N {0.5–1.5 kgf, 1.1–3.3 lbf}

3. If not within specification, replace the front lower arm.

Disassembly / Inspection / Assembly

1. Disassemble in the order shown in the figure, referring to **Disassembly Note**.
2. Inspect all parts and repair or replace as necessary.
3. Assemble in the reverse order of disassembly, referring to **Assembly Note**.

Caution

- When holding a part in a vise, use protective plates in the jaws to prevent damage to the part.

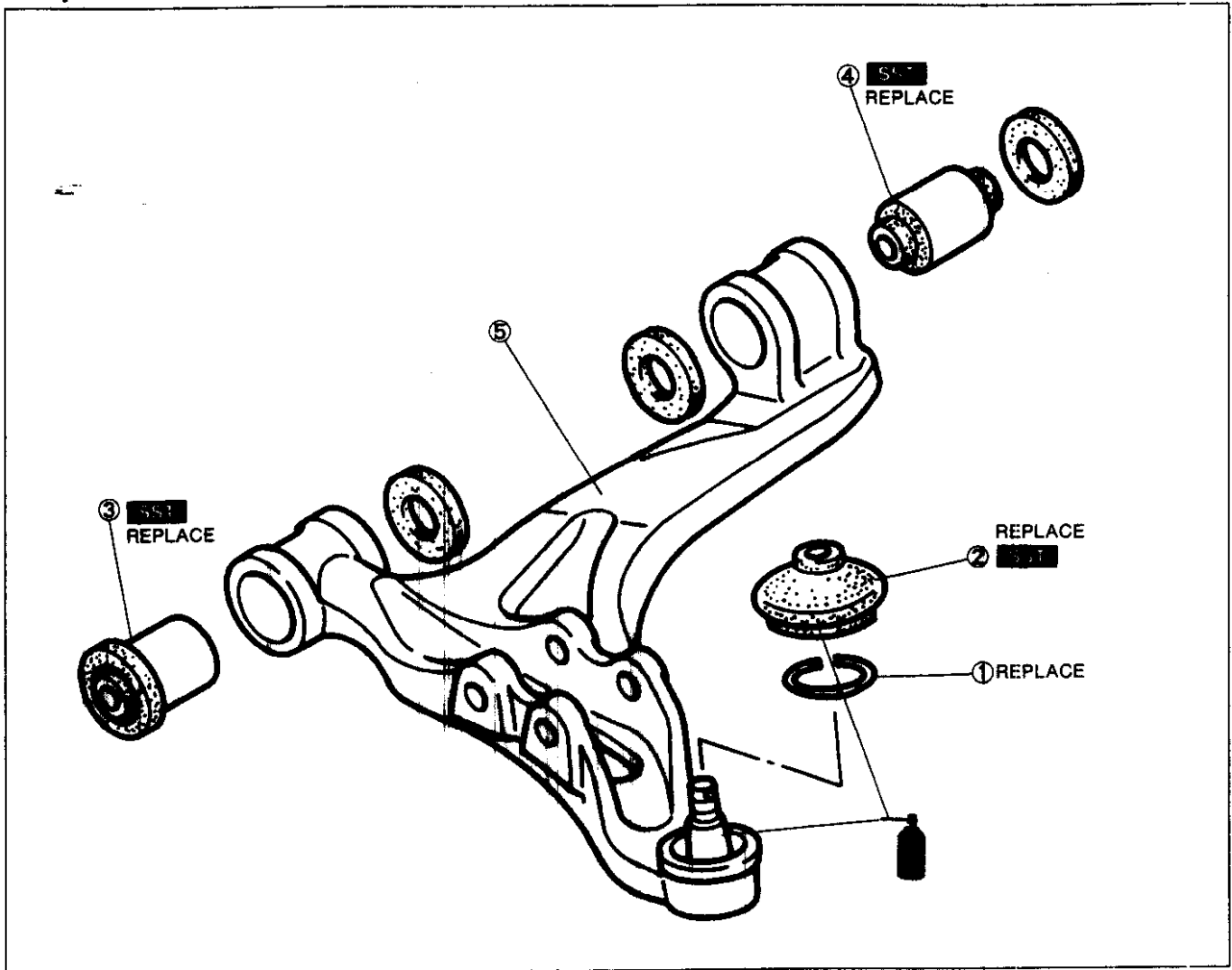

37U0R)-040

- | | | |
|---|--|---|
| <p>1. Clip
2. Dust boot
 Assembly Note page R-23
3. Bushing (front)
 Disassembly Note below
 Assembly Note page R-22</p> | <p>4. Bushing (rear)
 Disassembly Note
 page R-22
 Assembly Note page R-22</p> | <p>5. Front lower arm
 Inspect for damage and
 cracks</p> |
|---|--|---|

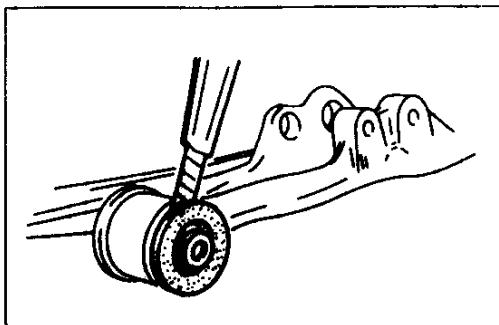

37U0RX-085

**Disassembly note
Bushings (front)**

1. Cut away the projecting rubber of the bushing.

R FRONT SUSPENSION (DOUBLE WISHBONE, COIL SPRING TYPE)

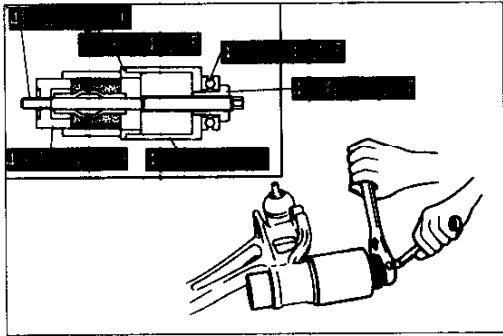

37U0RX-041

2. Remove the bushing by using the **SST**.

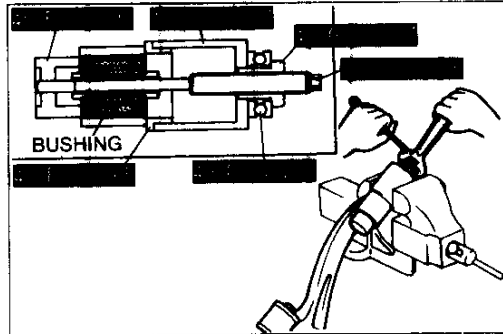

37U0RX-042

Bushing (rear)

- Remove the bushing by using the **SST**.

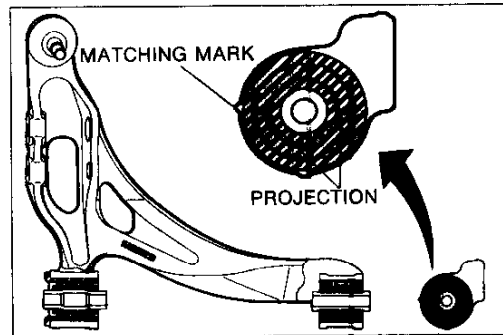

37U0RX-043

Assembly note Bushing (rear)

1. Align the matching marks.

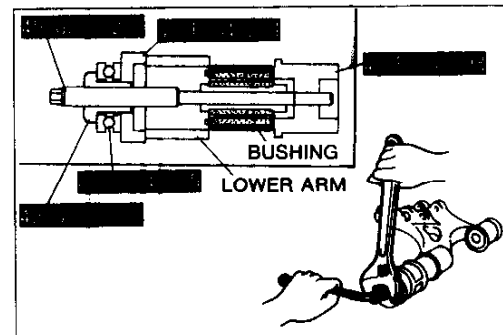

37U0RX-087

2. Apply soapy water to the new bushing.
3. Install the bushing by using the **SST**.

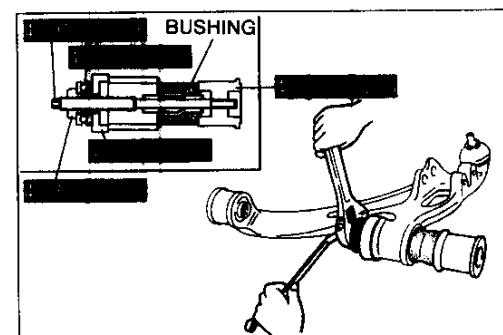

37U0RX-088

Bushing (front)

1. Apply soapy water to the new bushing.
2. Install the bushing by using the **SST**.

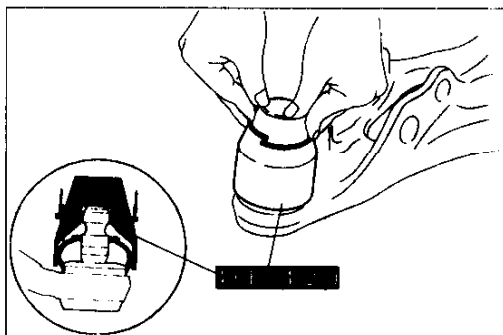

37U0RX-089

Dust boot

1. Wipe the grease off the ball stud.
2. Fill the inside the new dust boot with grease.
3. Install the dust boot onto the ball joint.
4. Set the **SST** over the boot and install a new clip.
5. Wipe off the excess grease.

R FRONT SUSPENSION (DOUBLE WISHBONE, COIL SPRING TYPE)

FRONT STABILIZER

Removal / Inspection / Installation

1. Jack up the front of the vehicle and support it on safety stands.
2. Remove the wheels and tires and the undercover.
3. Remove in the order shown in the figure.
4. Inspect all parts and repair or replace as necessary.
5. Install in the reverse order of removal, referring to **Installation Note**.
6. Install the wheels and tires.

Tightening torque: 89–117 N·m {9.0–12.0 kgf·m, 65–87 ft·lbf}

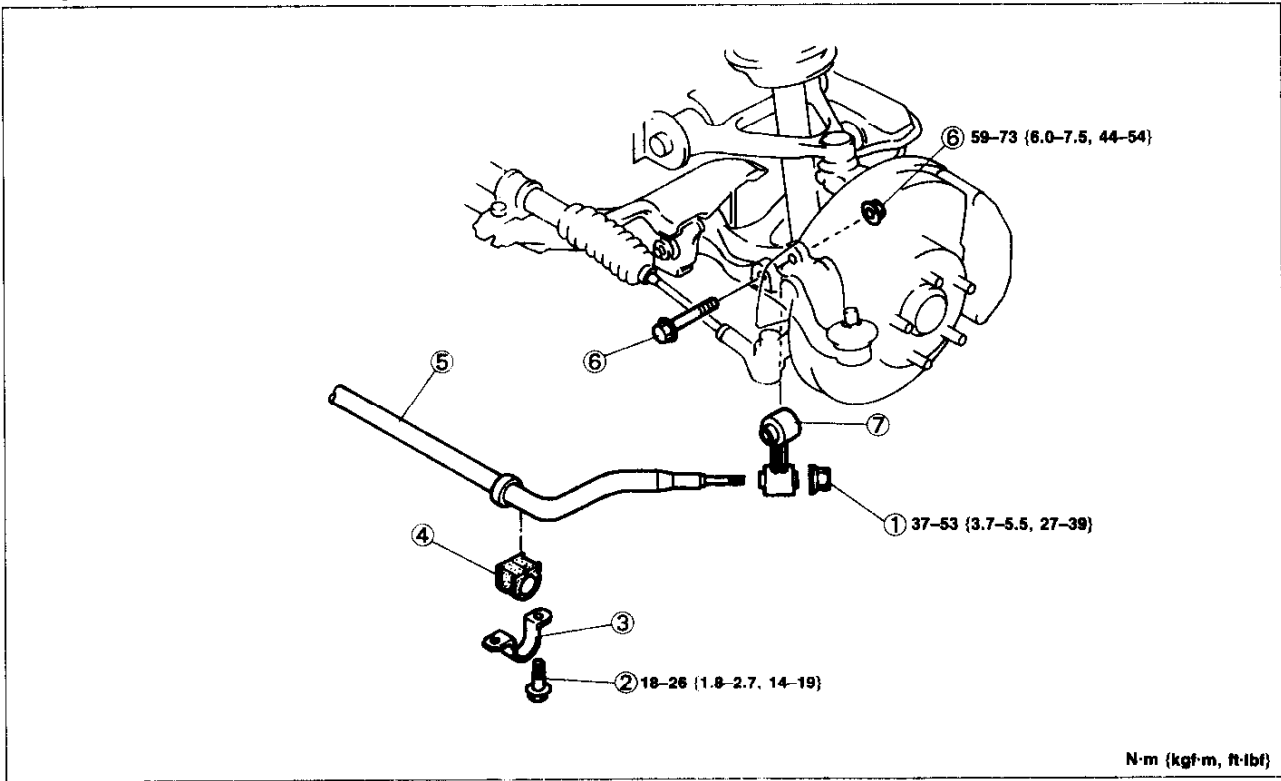

1. Nut
2. Bolt
3. Stabilizer plate
Inspect for damage and cracks
4. Stabilizer bushing
Inspect for wear and deterioration

5. Stabilizer bar
Inspect for damage and bending
Installation Note
..... page R-25

6. Bolt, nut
7. Stabilizer control link
Inspect for damage and cracks
Installation Note below

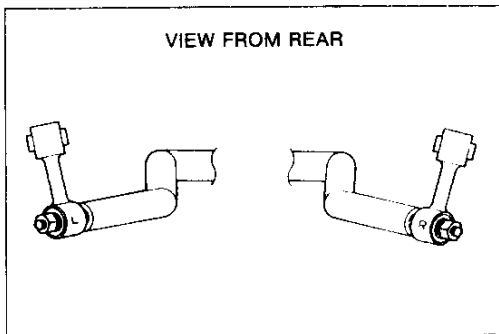

Installation note Stabilizer control link

Install the stabilizer control links with the R (right) and L (left) marks as shown.

37UORX-045

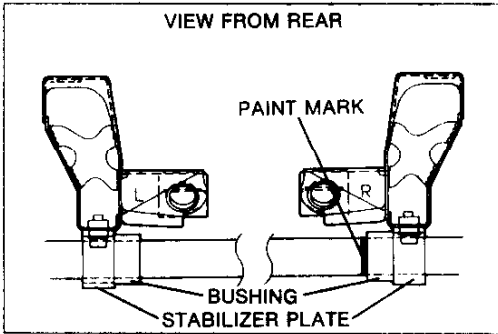

37U0RX-047

Stabilizer bar

Install the stabilizer bar with the white paint mark at the right side.

Note

- Install the stabilizer bar as shown in the figure.

FRONT STRUT BAR (R1 VEHICLE)

Removal / Inspection / Installation

1. Remove in the order shown in the figure.
2. Inspect all parts and repair or replace as necessary.
3. Install in the reverse order of removal, referring to **Installation Note**.

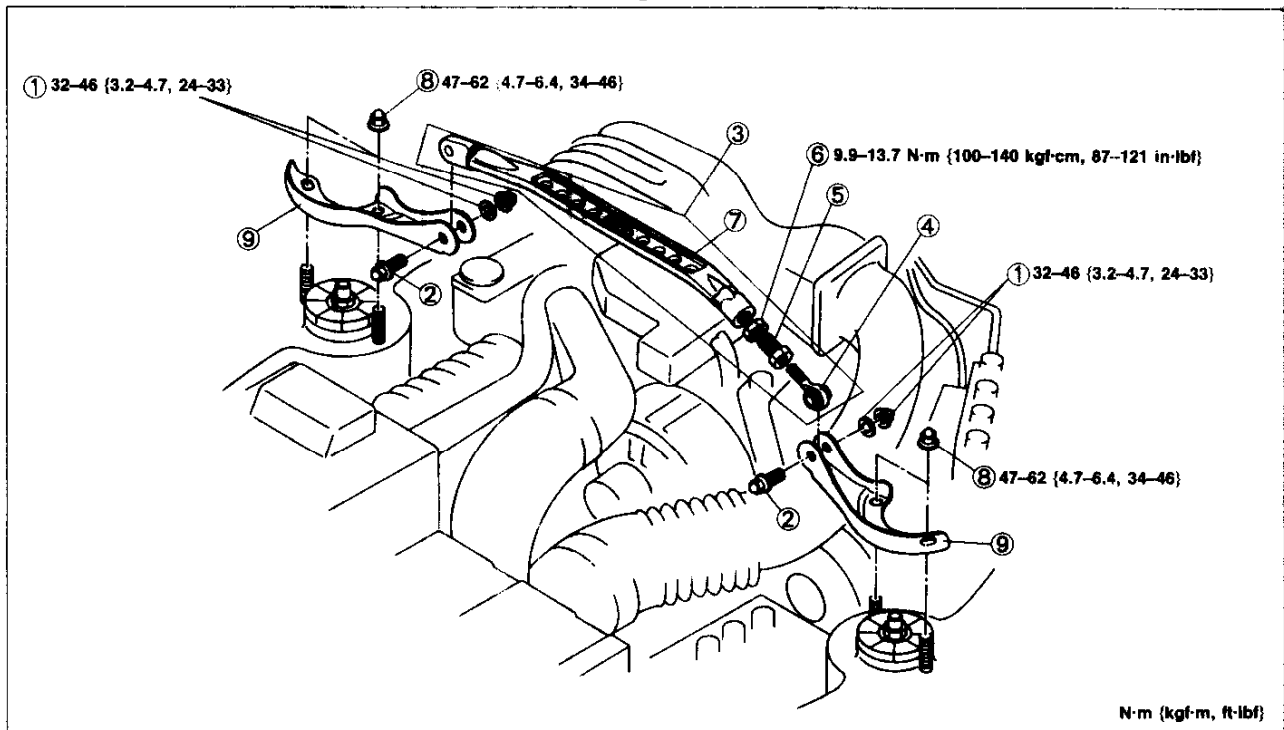

N·m (kgf·m, ft·lbf)

37U0RX-047

1. Nut, washer

2. Bolt

3. Strut bar assembly

Installation Note below

4. Joint A

5. Joint B

6. Locknut

7. Front strut bar

Inspect for damage and bending

8. Nut

9. Strut plate

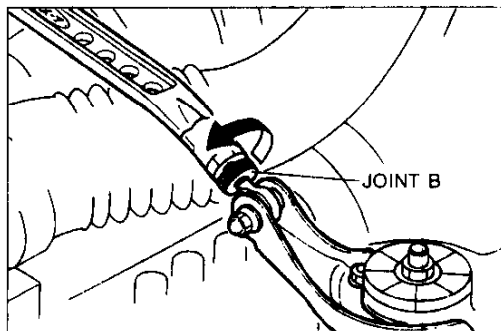

37U0RX-047

Installation note

Strut bar assembly

1. Turn joint B counterclockwise to the specified torque to set the tension.

Tightening torque:

0.40-0.58 N·m {4-6 kgf·cm, 3.5-5.2 in·lbf}

2. Tighten the locknut to the specified torque.







Tightening torque:

9.9-13.7 N·m {100-140 kgf·cm, 87-121 in·lbf}

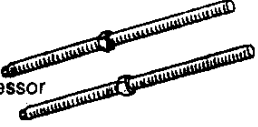
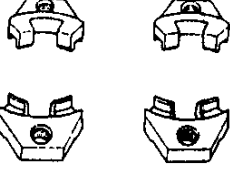
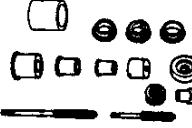
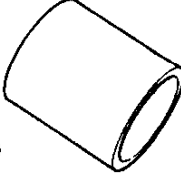
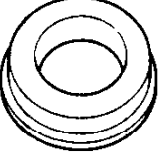
R REAR SUSPENSION (DOUBLE WISHBONE, COIL SPRING TYPE)

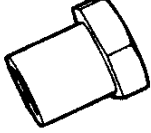
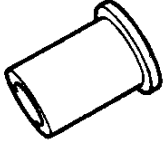
REAR SUSPENSION (DOUBLE WISHBONE, COIL SPRING TYPE)

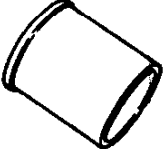
PREPARATION SST

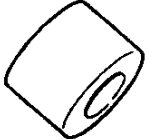
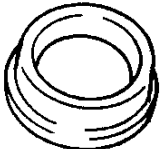
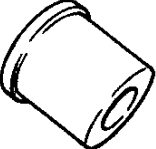
<p>49 0370 641</p> <p>Screw, coil spring compressor</p> 	<p>For removal / installation of coil spring</p>	<p>49 0223 640B</p> <p>Arm, coil spring compressor</p> 	<p>For removal / installation of coil spring</p>
<p>49 E034 2A0</p> <p>Replacer set, rubber bushing</p> 	<p>For removal / installation of bushing</p>	<p>49 G028 203</p> <p>Support</p> <p>(Part of 49 F034 2A0)</p> 	<p>For removal / installation of bushing</p>
<p>49 G028 205</p> <p>Support</p> <p>(Part of 49 F034 2A0)</p> 	<p>For removal / installation of pillow ball</p>	<p>49 G028 206</p> <p>Shaft</p> <p>(Part of 49 F034 2A0)</p> 	<p>For removal / installation of bushing</p>
<p>49 G028 207</p> <p>Nut</p> <p>(Part of 49 F034 2A0)</p> 	<p>For removal / installation of bushing</p>	<p>49 G028 208</p> <p>Installer</p> <p>(Part of 49 F034 2A0)</p> 	<p>For removal / installation of pillow ball</p>
<p>49 G034 205</p> <p>Bearing</p> <p>(Part of 49 F034 2A0)</p> 	<p>For removal / installation of bushing</p>	<p>49 F034 207</p> <p>Installer</p> <p>(Part of 49 F034 2A0)</p> 	<p>For removal / installation of bushing</p>
<p>49 F034 203</p> <p>Support</p> <p>(Part of 49 F034 2A0)</p> 	<p>For installation of bushing</p>	<p>49 F034 206</p> <p>Shaft</p> <p>(Part of 49 F034 2A0)</p> 	<p>For installation of bushing</p>
<p>49 F034 209</p> <p>Installer</p> <p>(Part of 49 F034 2A0)</p> 	<p>For installation of pillow ball</p>	<p>49 F034 204</p> <p>Support</p> <p>(Part of 49 F034 2A0)</p> 	<p>For removal / installation of bushing</p>
<p>49 F034 208</p> <p>Installer</p> <p>(Part of 49 F034 2A0)</p> 	<p>For removal / installation of bushing</p>	<p style="text-align: right;">37U0RX-(49</p>	

REAR SHOCK ABSORBER AND SPRING

Removal / Installation

1. Jack up the rear of the vehicle and support it on safety stands.
2. Remove the wheel and tire.
3. Remove in the order shown in the figure.
4. Install in the reverse order of removal, referring to **Installation Note**.
5. Install the wheel and tire.

Tightening torque: 89–117 N·m (9.0–12.0 kgf·m, 65–87 ft·lbf)

6. Check the rear wheel alignment. (Refer to page R-9.)

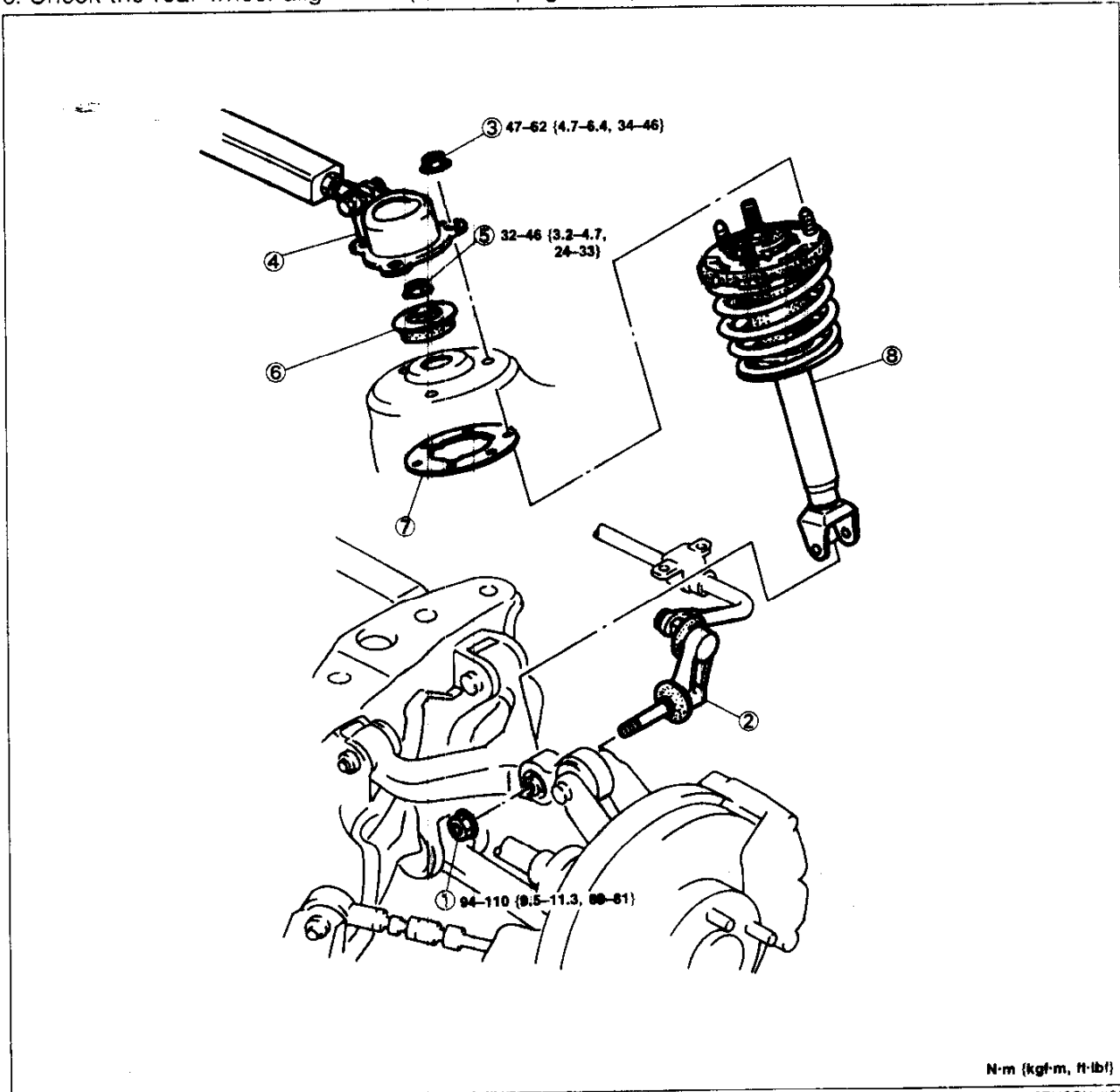

N·m (kgf·m, ft·lbf)

37U0RX-050

1. Nut
2. Rear stabilizer control link
3. Nut
4. Rear strut bar
Removal / Inspection /
Installation page R-43

5. Nut
6. Stopper rubber
7. Insulator

8. Shock absorber and
spring
Installation Note
..... page R-28
Disassembly / Inspection /
Assembly page R-29

R

REAR SUSPENSION (DOUBLE WISHBONE, COIL SPRING TYPE)

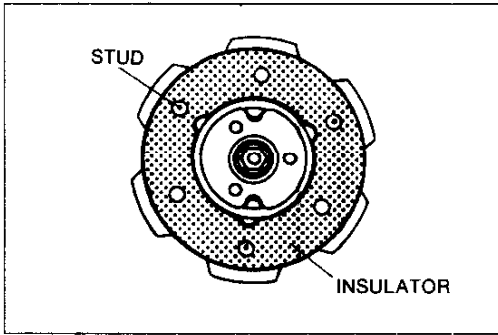

37U0RX-051

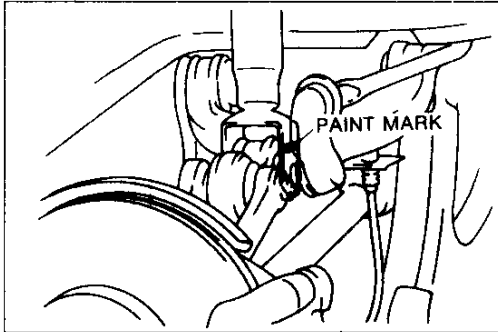

37U0RX-052

Installation note Shock absorber and spring

1. Install the insulator so that the notches in it face the studs as shown.
2. Install the shock absorber and spring so that the identification paint mark faces rearward.

Disassembly / Inspection / Assembly

1. Disassemble in the order shown in the figure, referring to **Disassembly Note**.
2. Inspect all parts and repair or replace as necessary.
3. Assemble in the reverse order of removal, referring to **Assembly Note**.

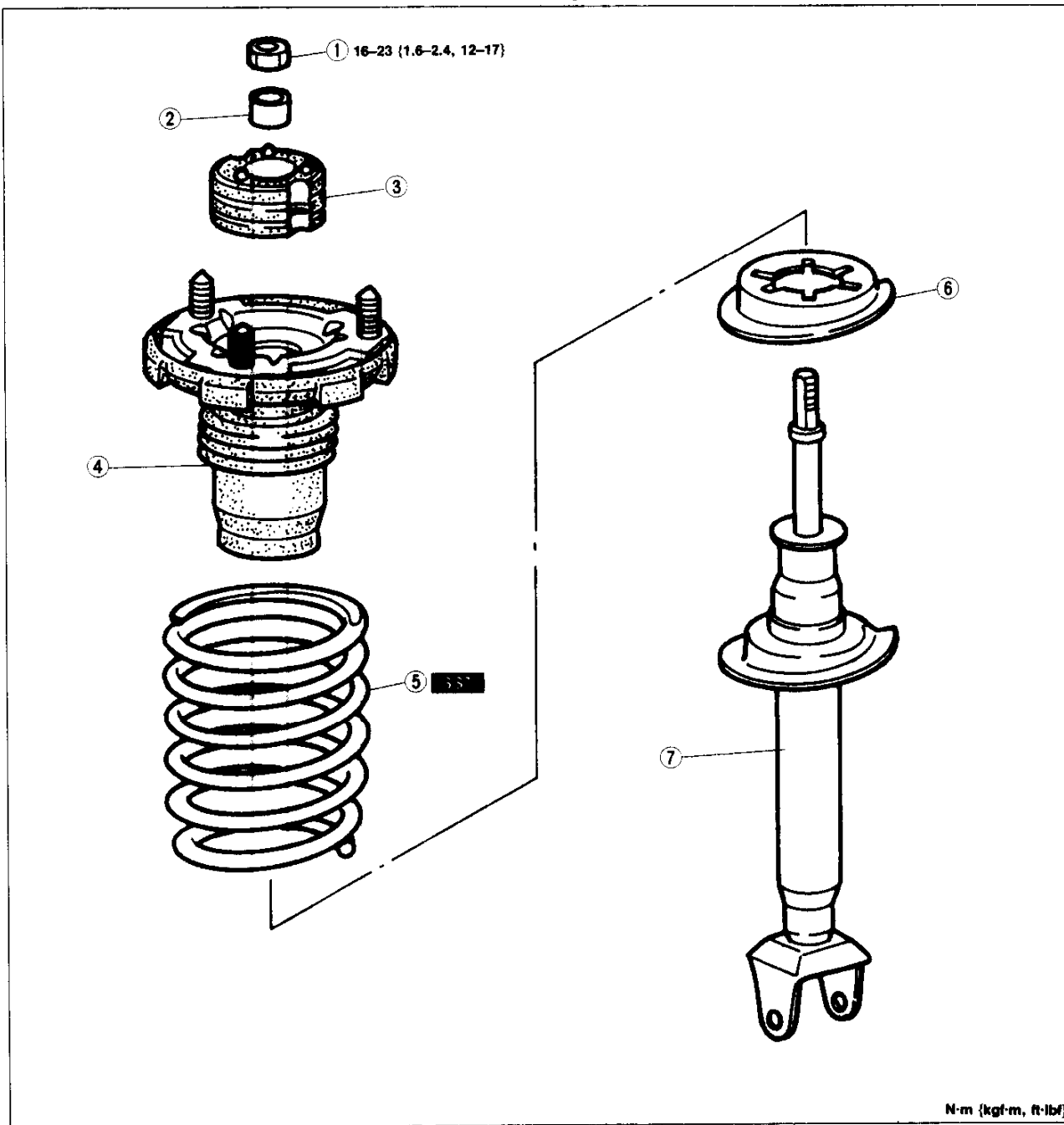

- 1. Nut
Disassembly Note page R-30
Assembly Note page R-31
- 2. Spacer
- 3. Mounting rubber
Inspect for damage and deterioration
Assembly Note page R-31

- 4. Bound stopper assembly
Inspect for damage and cracks
- 5. Coil spring
Inspect for damage and weakness
Assembly Note page R-30

- 6. Lower spring seat
Inspect for damage and cracks
- 7. Shock absorber
Inspection page R-30

N·m (kgf·m, ft·lbf)

37UORX-053

R REAR SUSPENSION (DOUBLE WISHBONE, COIL SPRING TYPE)

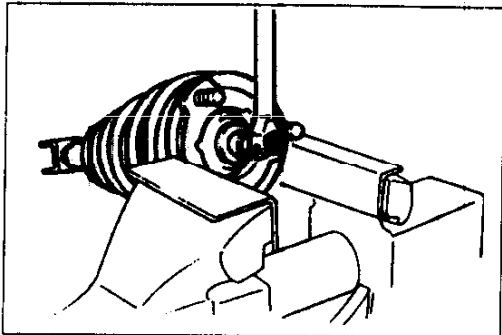

37UORX-098

Disassembly note Nut

Caution

- Use protective plates in the jaws of the vise to prevent damage to the bracket.

1. Secure the mounting rubber bracket in a vise.

Warning

- Because the coil spring is under considerable tension, do not remove the mounting rubber nut before installation of the SST.

2. Loosen the mounting rubber nut several turns, but do not remove it.
3. Assemble the SST.
4. Compress the coil spring by using the SST and remove the mounting nut.

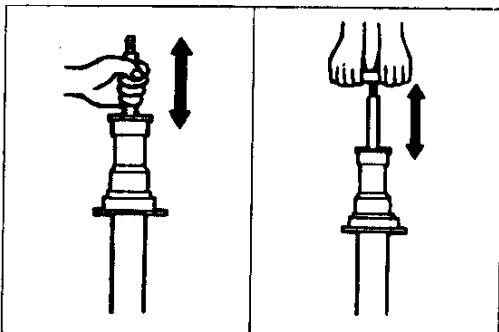
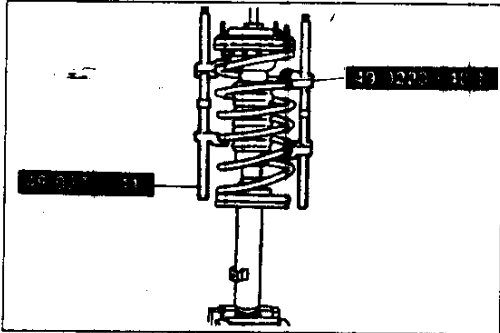

37UORX-099

Inspection Shock absorber

Check the following and replace the shock absorber if necessary.

1. Inspect for damage and oil leakage.
2. (1) Compress the shock absorber rod and release it.
(2) Verify that the rod extends fully at a normal speed.
3. Compress and extend the rod at least three times. Verify that the operational force does not change and that there is no unusual noise.

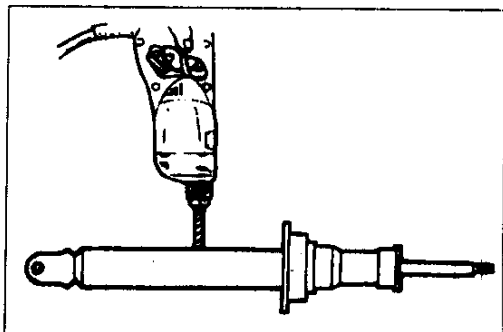

37UORX-100

Disposal of shock absorber

Caution

- The gas in the shock absorber is colorless, odorless, and nontoxic.
- Wear safety glasses because drilling chips may be blown out by the pressurized gas.

1. Lay the shock absorber flat.
2. Drill a hole in its body.

Drill size: 2–3 mm {0.08–0.12 in}

3. Allow the gas to escape.
4. Discard the shock absorber.

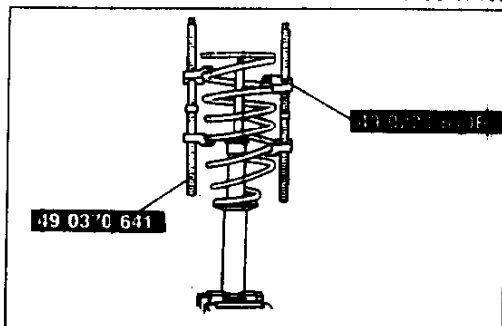

29UORX-061

Assembly note Coil spring

1. Compress the coil spring by using the SST.
2. Install the spring so that the lower coil is seated on the step of the lower seat.

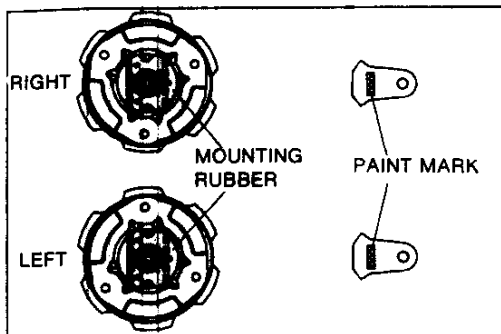

37UORX-055

Mounting rubber

Install the mounting rubber as shown.

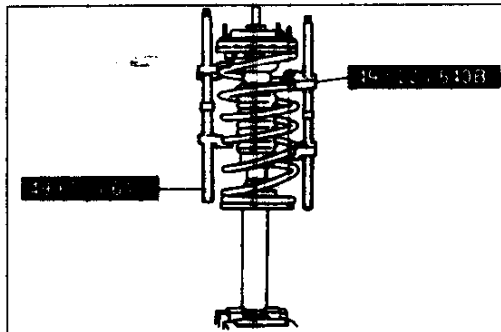

37UORX-056

Nut

1. Tighten the mounting nut several turns.
2. Remove the **SST**.

Caution

- Verify that the lower coil of the spring is seated on the step of the lower seat.

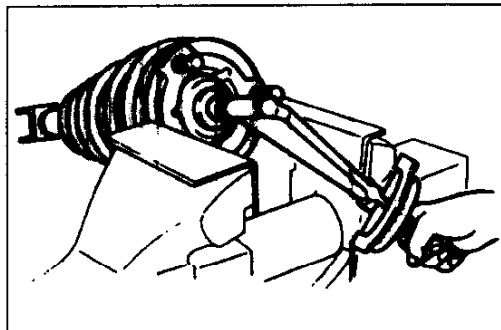

37UORX-057

3. Secure the mounting rubber bracket in a vise.
4. Tighten the nut.

Tightening torque:

16-23 N·m {1.6-2.4 kgf-m, 12-17 ft·lbf}

R REAR SUSPENSION (DOUBLE WISHBONE, COIL SPRING TYPE)

UPPER ARM

Removal / Inspection / Installation

1. Jack up the rear of the vehicle and support it on safety stands.
2. Remove the wheel and tire.
3. Remove in the order shown in the figure.
4. Inspect all parts and repair or replace as necessary.
5. Install in the reverse order of removal.
6. Install the wheel and tire.

Tightening torque: 89–117 N·m {9.0–12.0 kgf·m, 65–87 ft·lbf}

7. Check the rear wheel alignment. (Refer to page R-9.)

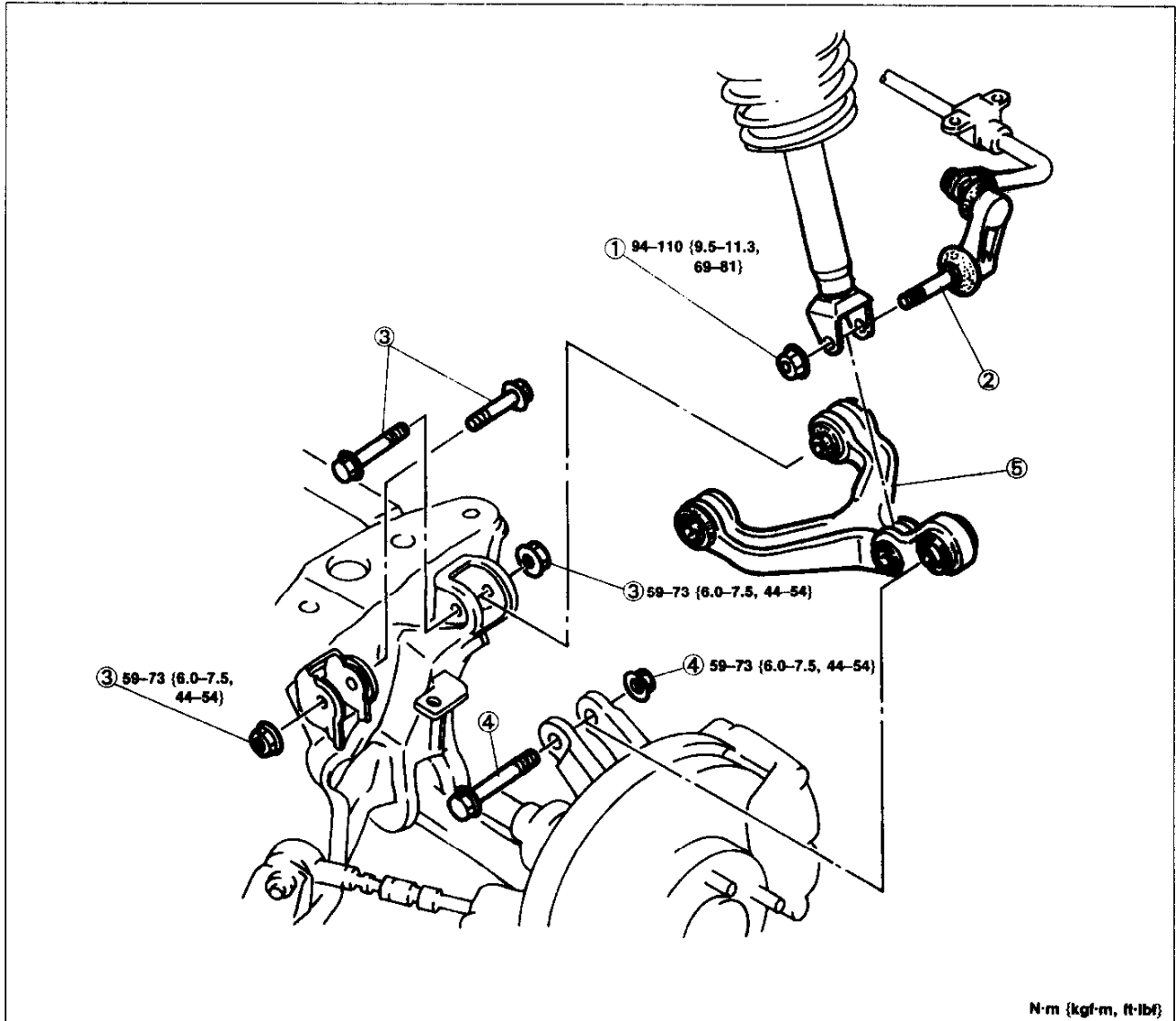

1. Nut
2. Stabilizer control link

3. Nut, bolt
4. Nut, bolt

5. Upper arm
Inspect for damage and cracks
Inspect bushing for wear and deterioration
Disassembly / Inspection / Assembly page R-33

Disassembly / Inspection / Assembly

1. Disassemble in the order shown in the figure, referring to **Disassembly Note**.
2. Inspect all parts and repair or replace as necessary.
3. Assemble in the reverse order of disassembly, referring to **Assembly Note**.

Caution

- **When holding a part in a vise, use protective plates in the jaws to prevent damage to the part.**

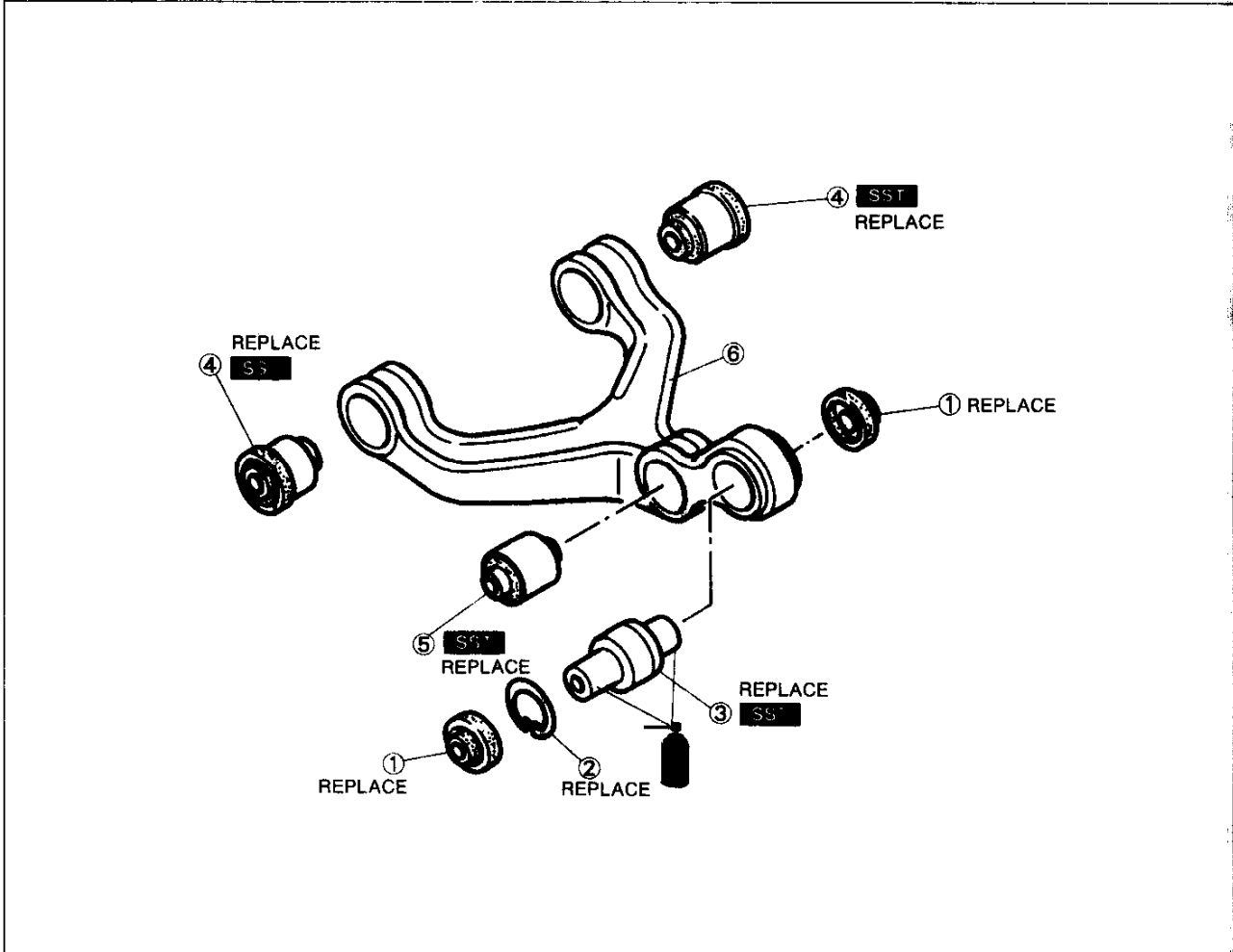

1. Rubber seal
2. Retaining ring
3. Pillow ball
Disassembly Note ... below
Assembly Note
..... page R-35

4. Upper arm bushing
Disassembly Note
..... page R-34
Assembly Note
..... page R-34

5. Damper bushing
Disassembly Note
..... page R-34
Assembly Note
..... page R-34
6. Upper arm
Inspect for damage and cracks

37U0RX-059

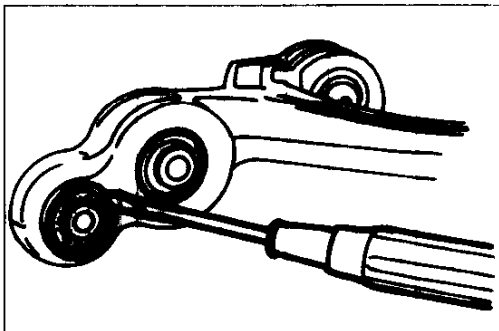

37U0RX-060

Disassembly note

Pillow ball

1. Remove the rubber seal by using a screw driver as shown.

Caution

- **Do not damage the upper arm.**

2. Remove the retaining ring.

R

REAR SUSPENSION (DOUBLE WISHBONE, COIL SPRING TYPE)

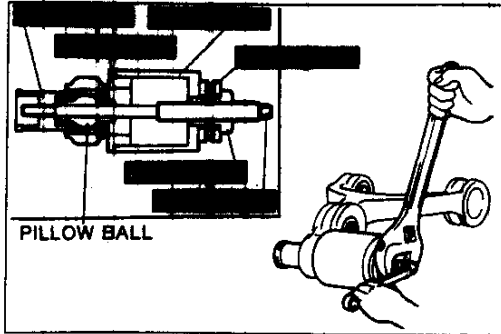

37U0RX-090

3. Remove the pillow ball by using the **SST**.

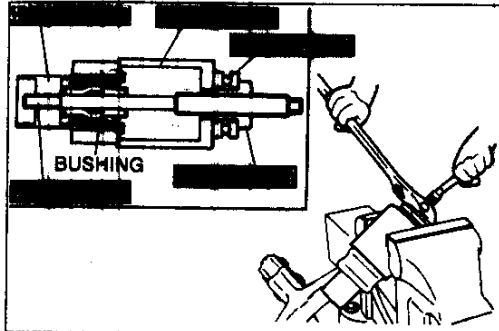

37U0RX-061

Upper arm bushing

Remove the upper arm bushing by using the **SST**.

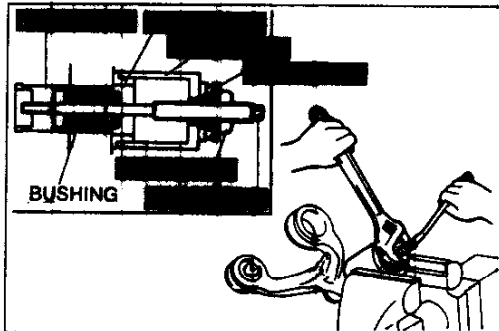

37U0RX-062

Damper bushing

Remove the damper bushing by using the **SST**.

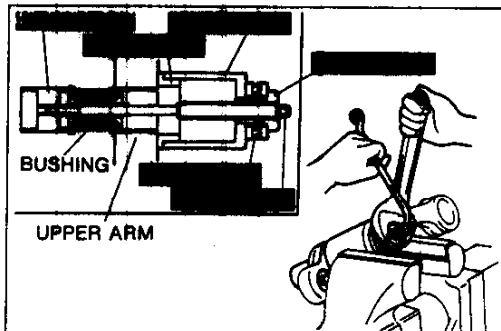

37U0RX-063

Assembly note Damper bushing

1. Apply soapy water to the new damper bushing.
2. Install the damper bushing by using the **SST**.

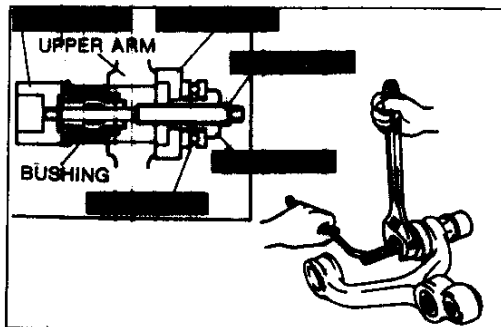

37U0RX-064

Upper arm bushing

1. Apply soapy water to the new bushing.
2. Install the upper arm bushing by using the **SST**.

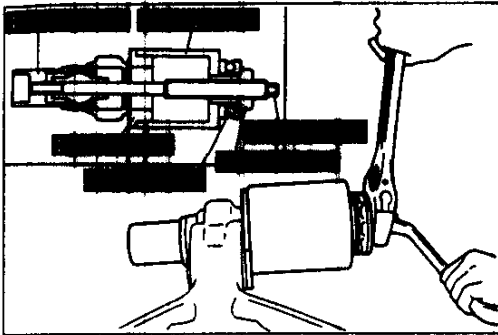

37UORX-065

Pillow ball

1. Install the new pillow ball by using the **SST**

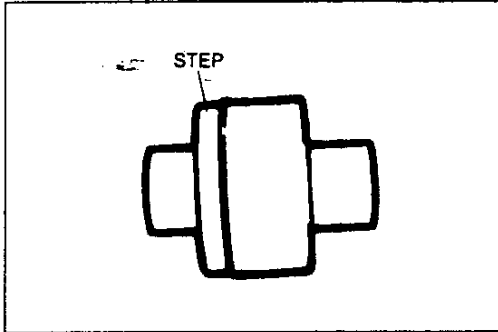

37UORX-091

Note

- Install the pillow ball with the step facing into the upper arm.
2. Install the retaining ring.
 3. Fill the space between the pillow ball and rubber seal with grease.
 4. Install the rubber seal.

R

REAR SUSPENSION (DOUBLE WISHBONE, COIL SPRING TYPE)

REAR LOWER ARM

Removal / Inspection / Installation

1. Jack up the rear of the vehicle and support it on safety stands.
2. Remove the wheel and tire.
3. Remove in the order shown in the figure, referring to **Removal Note**.
4. Inspect all parts and repair or replace as necessary.
5. Install in the reverse order of removal, referring to **Installation Note**.
6. Install the wheel and tire.

Tightening torque: 89–117 N·m {9.0–12.0 kgf·m, 65–87 ft·lbf}

Caution

- Loosely tighten the front nut of the trailing link. Lower the vehicle and tighten the nut to the specified torque with the vehicle unladen.

Tightening torque: 94–116 N·m {9.5–11.9 kgf·m, 69–86 ft·lbf}

7. Check the rear wheel alignment. (Refer to page R-9.)

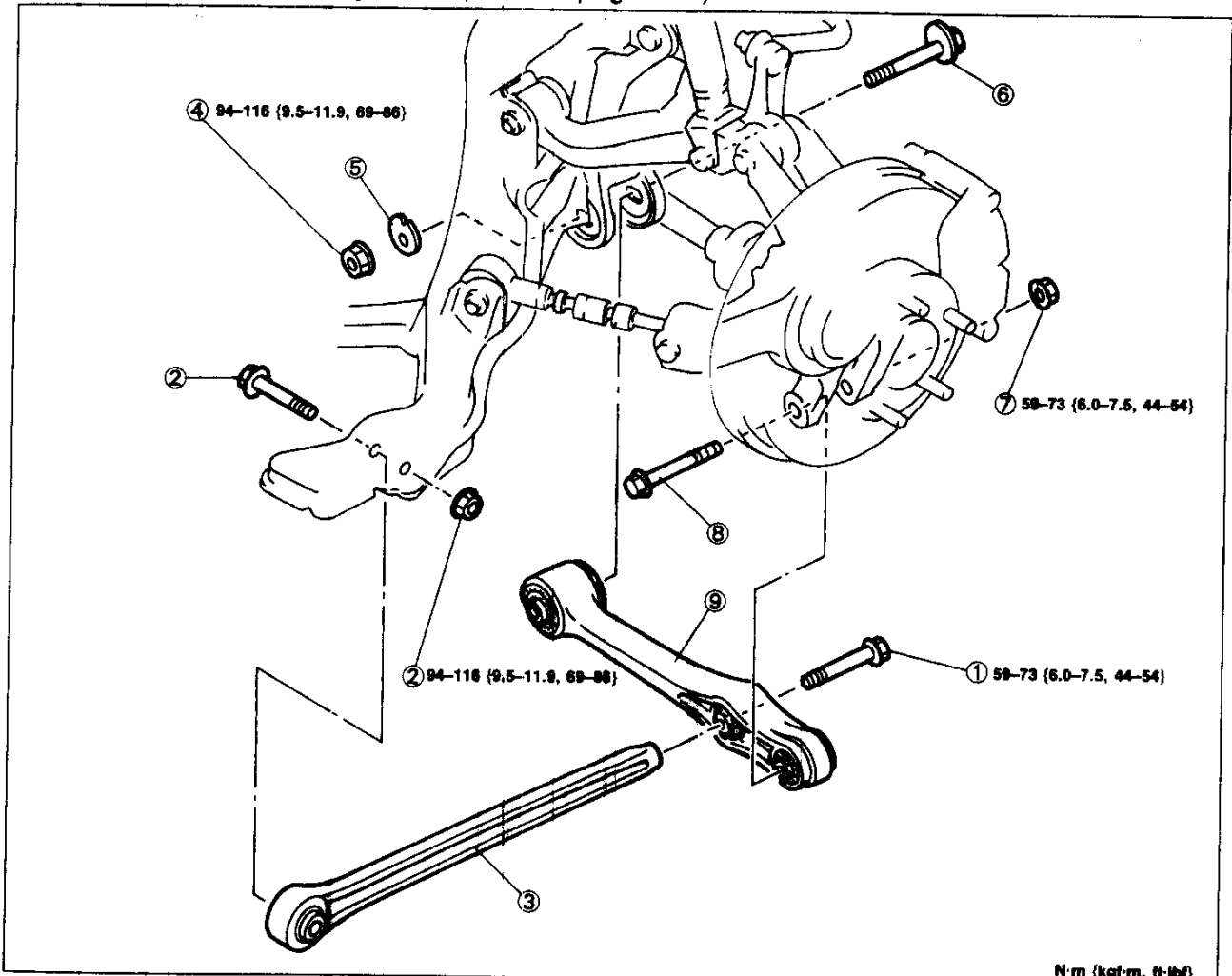

N·m {kgf·m, ft·lbf}

37U0RX-066

- | | | |
|---|---|--|
| <p>1. Bolt</p> <p>2. Bolt, nut</p> <p>3. Trailing link
Inspect for damage and cracks
Inspect bushing for wear and deterioration
Disassembly / Inspection / Assembly page R-37</p> | <p>4. Nut
Removal Note page R-20
Installation Note ... page R-20</p> <p>5. Cam plate
Removal Note page R-20
Installation Note ... page R-20</p> <p>6. Adjusting cam bolt
Installation Note ... page R-20</p> <p>7. Nut</p> <p>8. Bolt</p> | <p>9. I-arm
Inspect for damage and cracks
Inspect bushing for wear and deterioration
Disassembly / Inspection / Assembly page R-37</p> |
|---|---|--|

Disassembly / Inspection / Assembly

1. Disassemble in the order shown in the figure, referring to **Disassembly Note**.
2. Inspect all parts and repair or replace as necessary.
3. Assemble in the reverse order of disassembly, referring to **Assembly Note**.

Caution

- When holding a part in a vise, use protective plates in the jaws to prevent damage to the part.

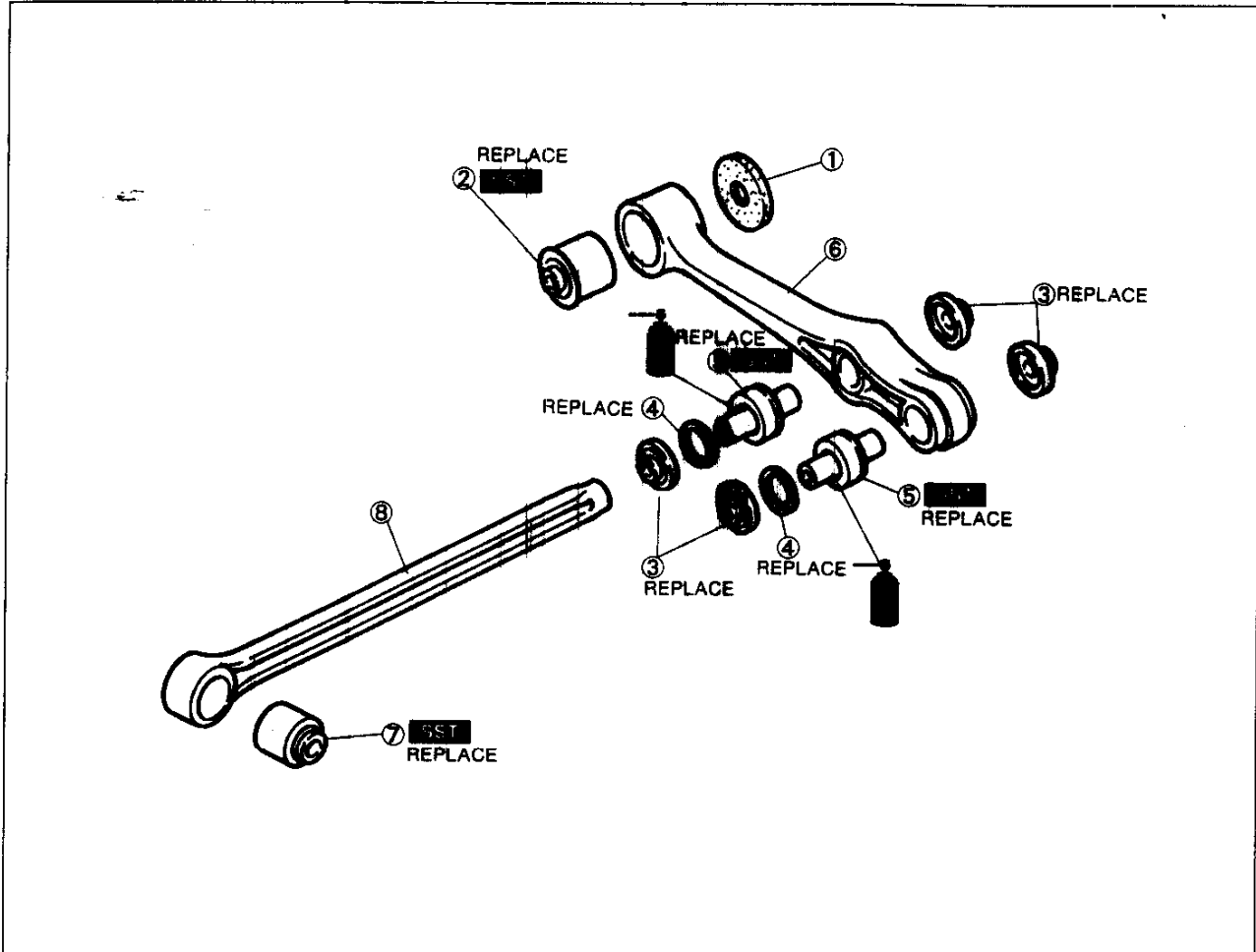

37U0RX-067

- | | | |
|--|---|---|
| <p>1. Stopper</p> <p>2. Pillow ball bushing
Disassembly Note ... below
Assembly Note page R-39</p> <p>3. Rubber seal</p> <p>4. Retaining ring</p> | <p>5. Pillow ball
Disassembly Note
..... page R-38
Assembly Note page R-39</p> <p>6. I-arm
Inspect for damage and
cracks</p> | <p>7. Bushing
Disassembly Note
..... page R-38
Assembly Note page R-38</p> <p>8. Trailing link
Inspect for damage and
cracks</p> |
|--|---|---|

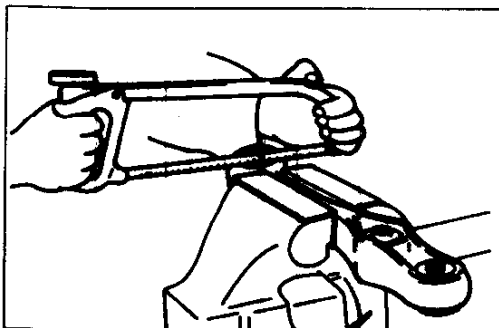

37U0RX-068

Disassembly note Pillow ball bushing

1. Cut away the flange of the bushing.

Caution

- Do not damage the I-arm.

R

REAR SUSPENSION (DOUBLE WISHBONE, COIL SPRING TYPE)

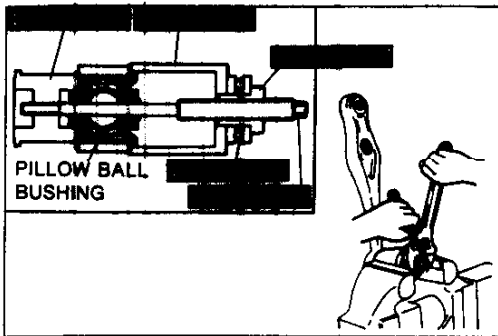

2. Remove the pillow ball bushing by using the **SST**.

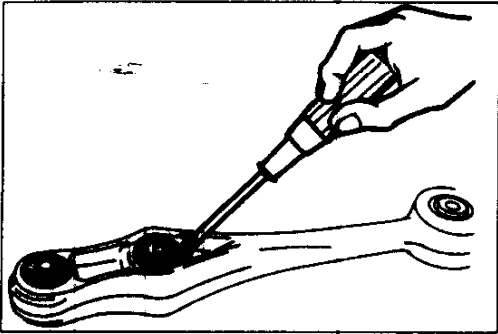

Pillow ball

1. Remove the rubber seal by using a screw driver as shown.

Caution

● Do not damage the I-arm.

2. Remove the retaining ring.

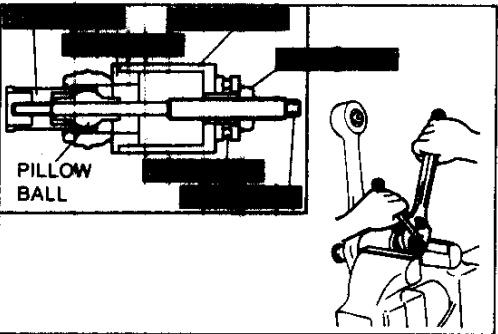

3. Remove the pillow ball by using the **SST**.

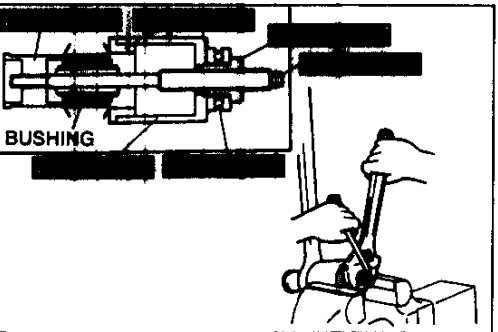

Bushing

Remove the bushing by using the **SST**.

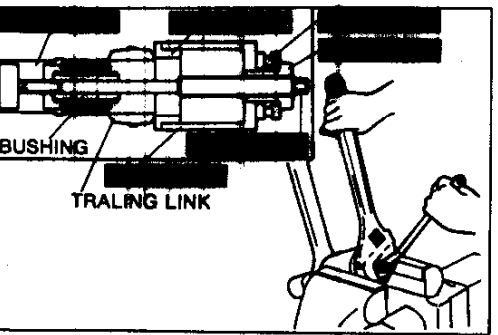

Assembly note

Bushing

1. Apply soapy water to the new bushing.
2. Install the bushing by using the **SST**.

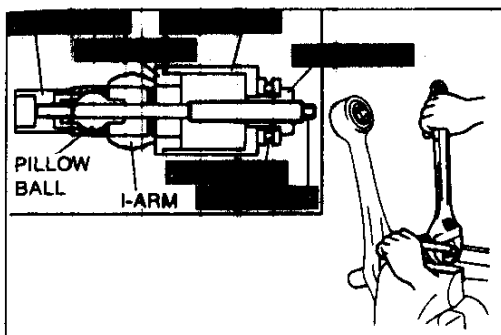

37U0RX-072

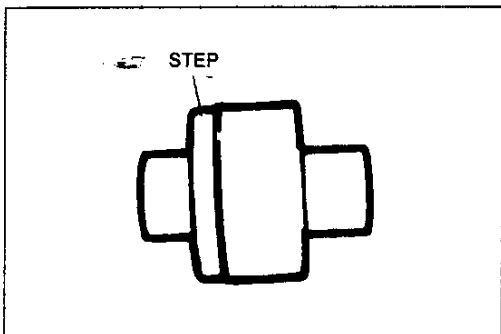

37U0RX-094

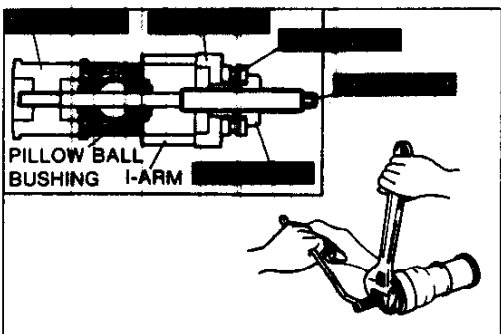

37U0RX-073

Pillow ball

1. Install the new pillow ball by using the **SST**.

Note

- Install the pillow ball with the step facing into the I-arm.

2. Install the retaining ring.
3. Fill the space between the pillow ball and rubber seal with grease.
4. Install the rubber seal.

Pillow ball bushing

1. Apply soapy water to the new pillow ball bushing.
2. Install the pillow ball bushing by using the **SST**.

R REAR SUSPENSION (DOUBLE WISHBONE, COIL SPRING TYPE)

TOE-CONTROL LINK

Removal / Inspection / Installation

1. Jack up the rear of the vehicle and support it on safety stands.
2. Remove the wheel and tire.
3. Remove in the order shown in the figure.
4. Inspect all parts and repair or replace as necessary.
5. Install in the reverse order of removal, referring to **Installation Note**.
6. Install the wheel and tire.

Tightening torque: 89–117 N·m (9.0–12.0 kgf·m, 65–87 ft·lbf)

7. Check the rear wheel alignment. (Refer to page R-9.)

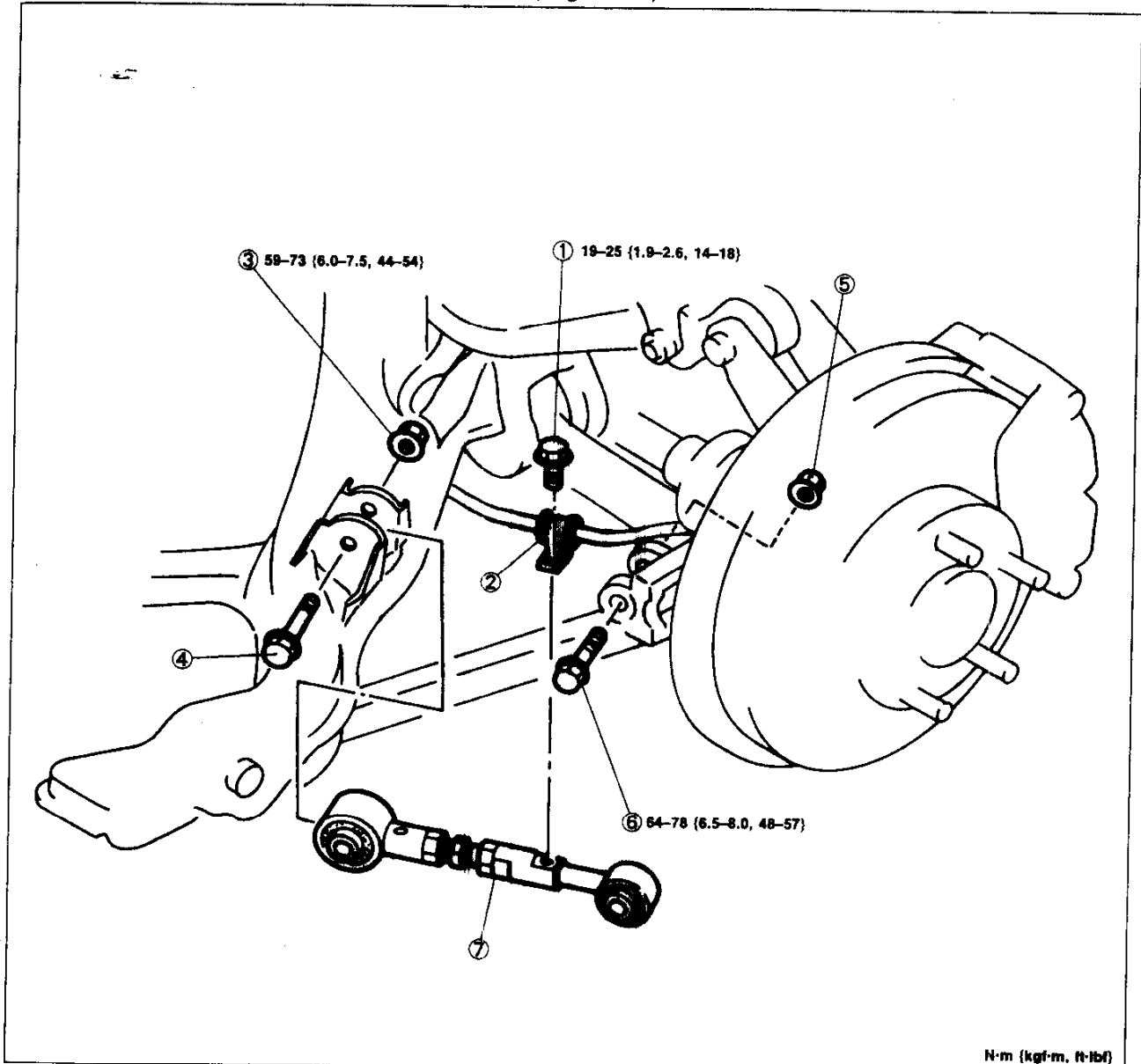

- 1. Bolt
- 2. ABS wheel-speed sensor harness
- 3. Nut

- 4. Bolt
- 5. Nut
- 6. Bolt

- 7. Toe-control link
Inspect bushing for wear and deterioration
Installation Note

..... page R-41

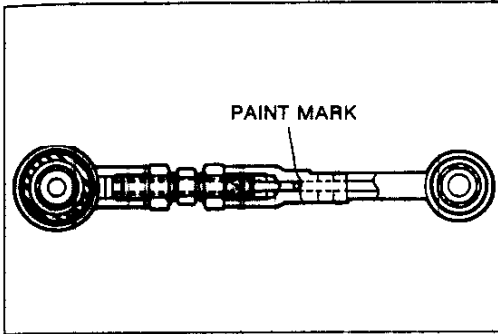

37U0RX-075

Installation note

Toe-control link

Install the toe-control link with the paint mark facing upward.

R REAR SUSPENSION (DOUBLE WISHBONE, COIL SPRING TYPE)

REAR STABILIZER

Removal / Inspection / Installation

1. Jack up the rear of the vehicle and support it on safety stands.
2. Remove the wheels and tires and the undercover.
3. Remove in the order shown in the figure.
4. Inspect all parts and repair or replace as necessary.
5. Install in the reverse order of removal, referring to **Installation Note**.
6. Install the wheels and tires.

Tightening torque: 89–117 N·m {9.0–12.0 kgf·m, 65–87 ft·lb}

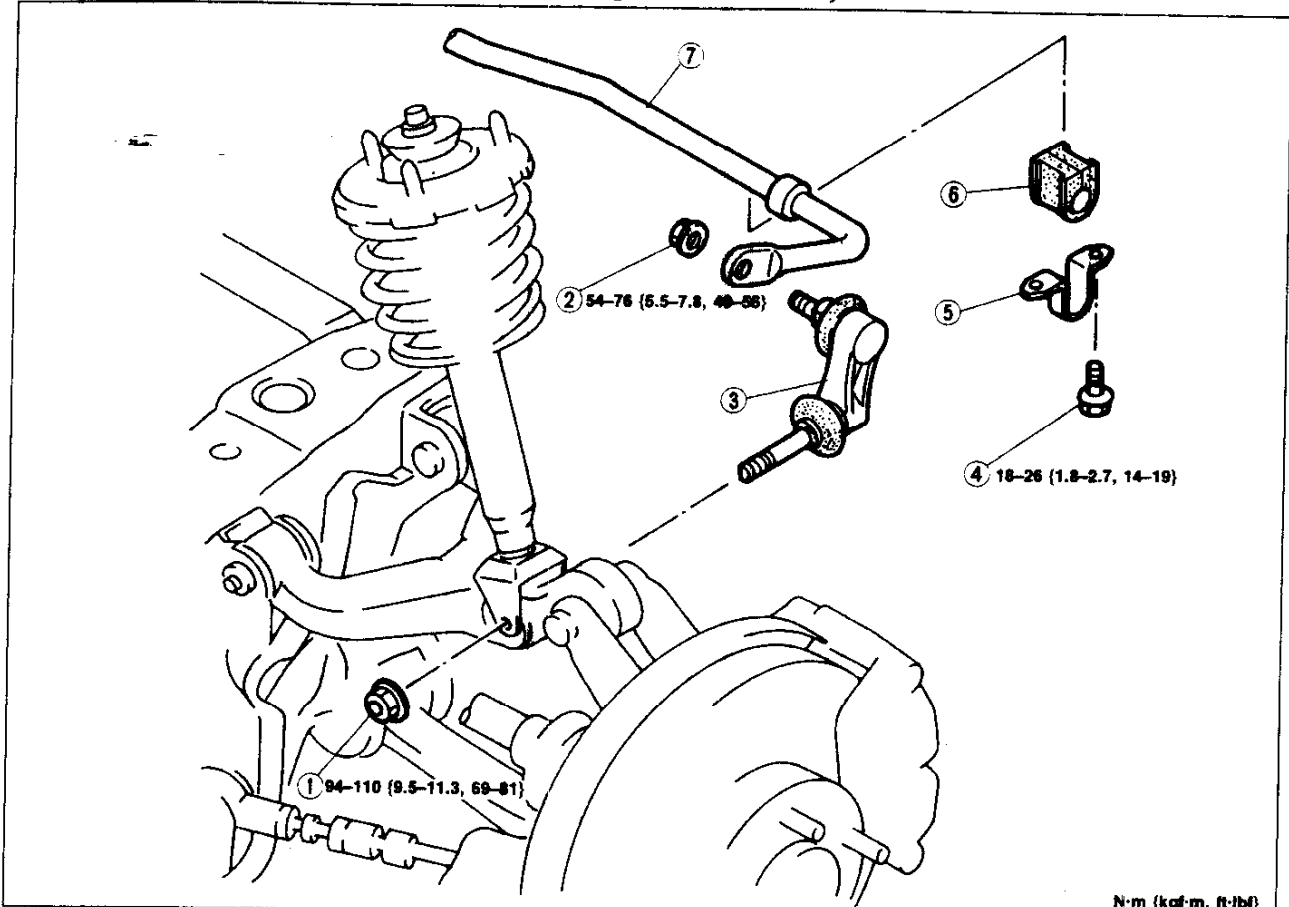

1. Nut
2. Nut
3. Stabilizer control link
Inspect for damage and cracks
Installation Note
..... page R-43

4. Bolt
5. Stabilizer plate
Inspect for damage and cracks
6. Stabilizer bushing
Inspect for wear and deterioration

7. Stabilizer bar
Inspect for damage and bending
Installation Note
..... below

37UORX-081

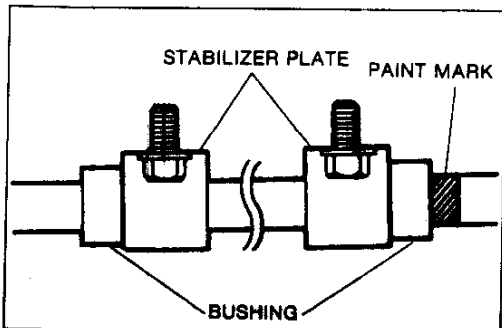

37UORX-082

Installation note Stabilizer bar

Install the stabilizer bar with the white paint mark at the right side.

Note

- Install the stabilizer bar as shown in the figure.

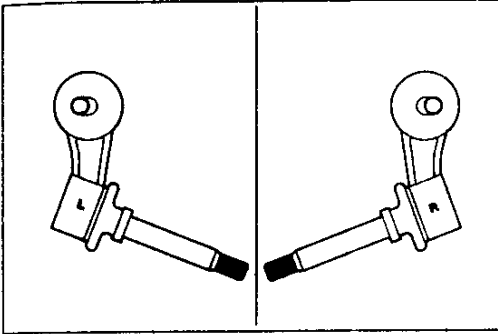

37U0RX-083

Stabilizer control link

Install the stabilizer control links with the R (right) and L (left) marks as shown.

REAR STRUT BAR

Removal / Inspection / Installation

1. Remove the suspension tower cover. (Refer to Section S.)
2. Remove in the order shown in the figure.
3. Inspect all parts and repair or replace as necessary.
4. Install in the reverse order of removal.

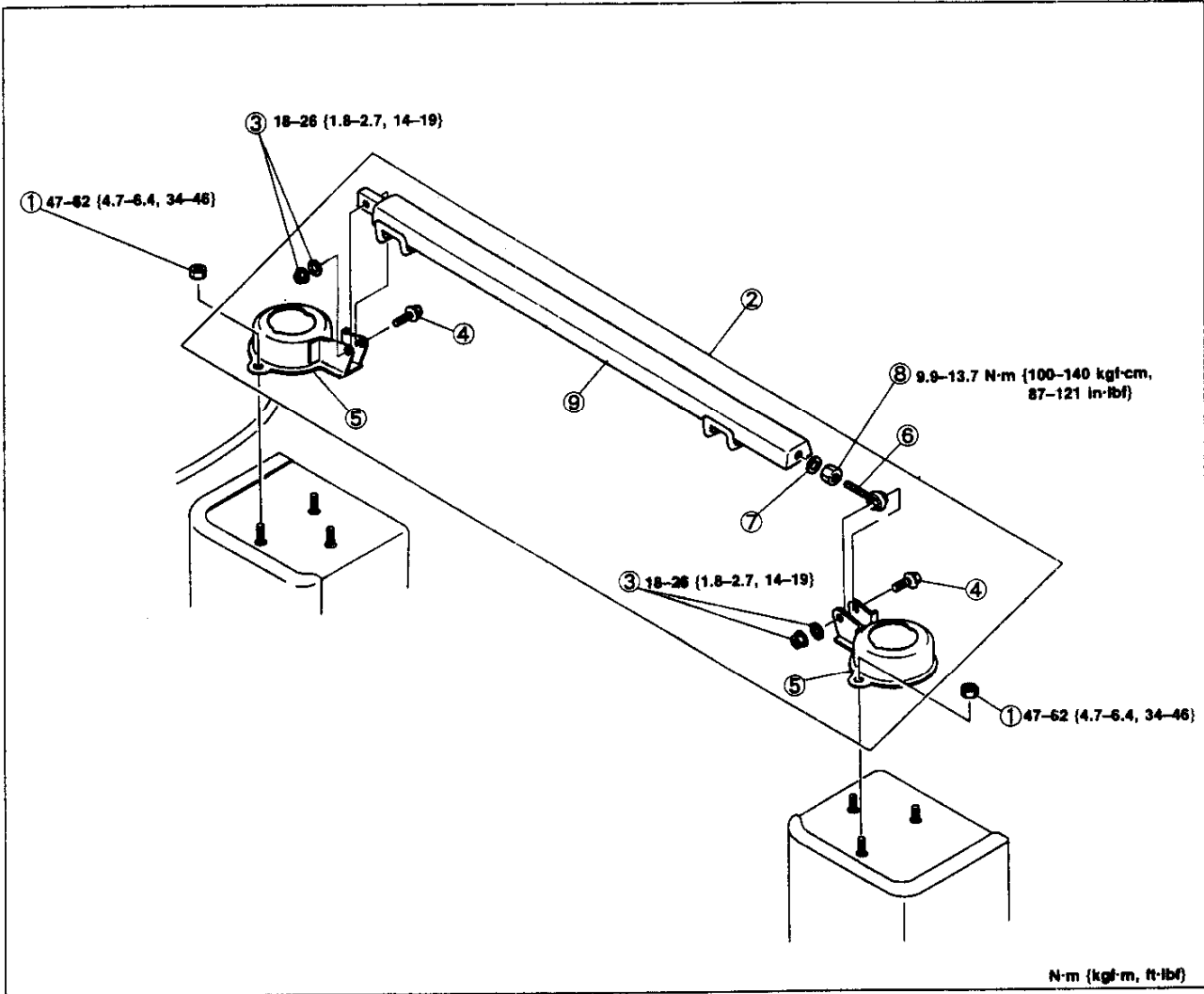

37U0RX-084

- 1. Nut
- 2. Strut bar assembly
- 3. Nut, washer

- 4. Bolt
- 5. Strut plate
- 6. Joint A
- 7. Washer

- 8. Nut
- 9. Rear strut bar
Inspect for damage and bending