

This file is available for free download at <http://www.iluvmyrx7.com>

This file was not scanned to deprive Mazda of any money – it was scanned due to the rareness of the original manuals and the overwhelming need of the RX-7 owner to have this information so that they can accurately troubleshoot problems. Perhaps if Mazda's dealerships could support the Rotary Engine it wouldn't be so necessary for the owners to do so.



Many thanks to Anh Diep for scanning this file.

Before beginning any service procedure, refer to Section S of this manual for air bag system service precautions, and to Section T for audio anti-theft system cautions.

FUEL AND EMISSION CONTROL SYSTEMS

INDEX	F - 2	SYSTEM OPERATION	F -126
OUTLINE	F - 7	EGR VALVE	F -127
SYSTEM DIAGRAM	F - 7	EGR SWITCH	F -127
WIRING DIAGRAM	F - 8	SOLENOID VALVE (EGR)	F -127
VACCUUM HOSE ROUTING DIAGRAM	F - 10	CATALYTIC CONVERTER SYSTEM	F -128
SPECIFICATIONS	F - 11	CATALYTIC CONVERTER	F -128
COMPONENT DESCRIPTIONS	F - 12	EVAPORATIVE EMISSION CONTROL	
ENGINE TUNE-UP	F - 15	SYSTEM	F -129
BASIC INSPECTION	F - 15	SYSTEM OPERATION	F -131
ADJUSTMENT	F - 16	SOLENOID VALVE (PURGE CONTROL)	F -131
SELF-DIAGNOSIS FUNCTION	F - 18	CHACOAL CANISTER	F -131
SERVICE CODE NUMBER	F - 20	CHECK VALVE (TWO WAY)	F -132
SWITCH MONITOR FUNCTION	F - 67	CHECK VALVE (ONE-WAY)	F -132
OXGEN SENSOR MONITOR FUNCTION	F - 71	SEPARATOR	F -132
REAL TIME MONITOR FUNCTION	F - 72	FUEL VAPOR VALVE	F -132
SIMULATION FUNCTION	F - 74	DECERATION CONTROL SYSTEM	F -133
INTAKE AIR SYSTEM	F - 76	DASH POT	F -134
AIR BYPASS VALVE	F - 77	ANTI AFTERBURN CONTROL	F -134
INTERCOOLER	F - 78	ELECTRICAL LOAD (E/L) CONTROL	
THROTTLE BODY	F - 79	SYSTEM	F -135
EXTENSION MANIFOLD	F - 79	SYSTEM OPERATION	F -136
INTAKE MANIFOLD	F - 79	DOUBLE THROTTLE CONTROL (DTCNT)	
ACCELERATOR PEDAL	F - 80	SYSTEM	F -137
ACCELERATOR CABLE	F - 80	SYSTEM OPERATION	F -139
IDLE-SPEED CONTROL (ISC) SYSTEM	F - 81	ACTUATOR	
SYSTEM OPERATION	F - 82	(DOUBLE THROTTLE CONTROL)	F -139
SOLENOID VALVE (ISC)	F - 83	A/C CUT-OFF SYSTEM	F -140
SOLENOID VALVE (AWS)	F - 83	SYSTEM OPERATION	F -142
SEQUENTIAL TWIN TURBOCHARGER		DECHOKER CONTROL SYSTEM	F -143
SYSTEM	F - 84	SYSTEM OPERATION	F -143
ACTUATOR (TURBO CONTROL)	F - 86	ELECTRICAL COOLING FAN CONTROL	
ACTUATOR (CHARGE CONTROL)	F - 87	SYSTEM	F -144
CHARGE RELIEF VALVE	F - 88	SYSTEM OPERATION	F -146
TURBO CHARGER	F - 89	FAN RELAY	F -146
SOLENOID VALVE (TURBO PRECONTROL, WASTEGASTE CONTROL)	F - 93	CONTROL SYSTEM	F -147
FUEL SYSTEM	F - 94	STRUCTURAL VIEW	F -148
PRECAUTION	F - 96	ENGINE CONTROL UNIT (ECU)	F -150
SYSTEM OPERATION	F - 97	CRANK ANGLE SENSOR	F -180
FUEL TANK	F - 98	PRESSURE SENSOR	F -181
FUEL PUMP	F -100	THROTTLE SENSOR	F -182
FUEL FILTER	F -103	WATER THERMOSENSOR	F -183
PRESSURE REGULATOR	F -104	INTAKE AIR THERMOSENSOR	F -183
INJECTOR	F -105	FUEL THERMOSENSOR	F -184
FUEL PUMP CONTROL SYSTEM	F -108	OXYGEN SENSOR	F -184
FUEL PUMP RESISTOR	F -109	KNOCK SENSOR	F -185
FUEL PUMP	F -110	POWER STEERING PRESSURE SWITCH	F -186
PRESSURE REGULATOR CONTROL (PRC)		STOPLIGHT SWITCH	F -186
SYSTEM	F -111	NEUTRAL SWITCH (MT)	F -186
SYSTEM OPERATION	F -112	CLUTCH SWITCH (MT)	F -187
EXHAUST SYSTEM	F -113	1-2 SWITCH (MT)	F -187
COMPONENT PARTS	F -113	MAIN RELAY (EGI RELAY)	F -188
OUTLINE OF EMISSION SYSTEM	F -114	CIRCUIT OPENING RELAY	F -188
STRUCTURAL VIEW	F -114	HEAT HAZARD SENSOR	F -189
SECONDARY AIR INJECTION SYSTEM	F -115	MILEAGE SWITCH	F -189
AIR CONTROL VALVE (ACV)	F -117	SOLENOID VALVES	F -190
SOLENOID VALVE (PORT AIR BYPASS)	F -119	TROUBLESHOOTING GUIDE	F -192
SOLENOID VALVE (SPLIT AIR BYPASS)	F -120	QUICK DIAGNOSIS CHART	F -192
AIR PUMP	F -121	RELATIONSHIP CHART	F -196
AIR PUMP DRIVE BELT	F -122	USING THIS SECTION	F -198
AIR PUMP RELAY	F -123	DIAGNOSTIC INDEX	F -200
SOLENOID VALVE (RELIEF2)	F -123	PRECAUTION	F -203
POSITIVE CRANKCASE VENTILATION (PCV)		SYMPTOM TROUBLESHOOTING	F -204
SYSTEM	F -124	SERVICE POINTS	F -232
PCV VALVE	F -124	OUTLINE	F -232
EXHAUST GAS RECIRCULATION (EGR)		WIRING DIAGRAM	F -238
CONTROL SYSTEM	F -125	ELECTRICAL DIAGNOSIS SUPPORT	F -242

INDEX

Intake Air System

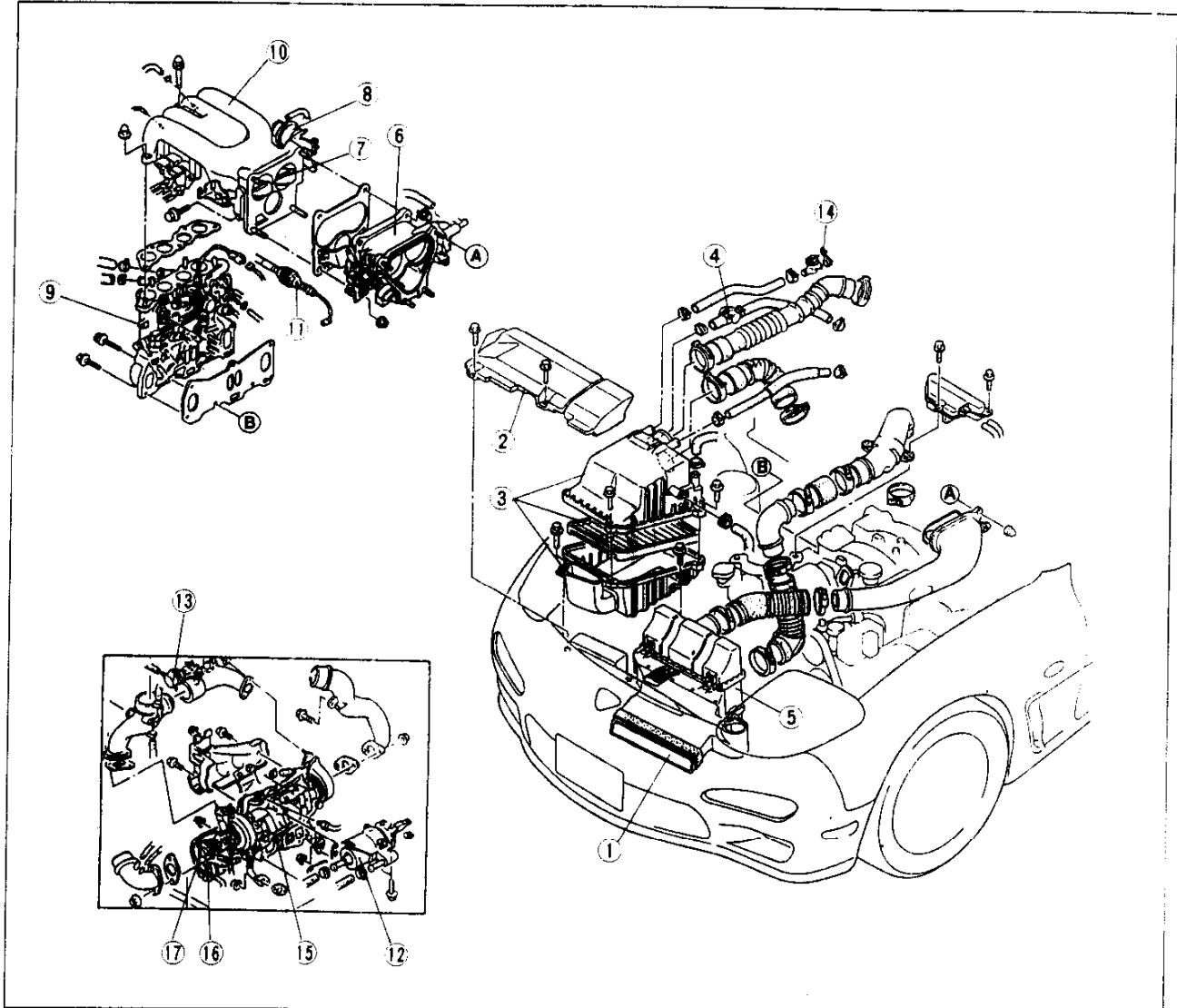

- 1. Fresh air duct
Removal / Inspection /
Installation page F- 76
- 2. Resonance chamber
Removal / Inspection /
Installation page F- 76
- 3. Air cleaner
Inspection page F- 16
- 4. Air bypass valve
Inspection page F- 77
- 5. Intercooler
Removal / Inspection /
Installation page F- 78
- 6. Throttle body
Inspection /
Adjustment page F- 79
- 7. Double Throttle valve
Inspection page F- 79
- 8. Actuator (Double throttle control)
Inspection page F-139

- 9. Intake manifold
Inspection page F- 79
- 10. Extension manifold
Installation page F- 80
- 11. Accelerator cable
Inspection / Adjustment page F- 80
- 12. Actuator (Turbo control)
Inspection page F- 86
- 13. Actuator (Charge control)
Inspection page F- 87
- 14. Change relief valve
Inspection page F- 88
- 15. Turbocharger
Inspection page F- 89
Removal / Installation page F- 91
- 16. Actuator (Turbo precontrol)
Inspection page F- 90
- 17. Actuator (Wastegate control)
Inspection page F- 91

17J0FX-002

Fuel System and Evaporative Emission Control System.

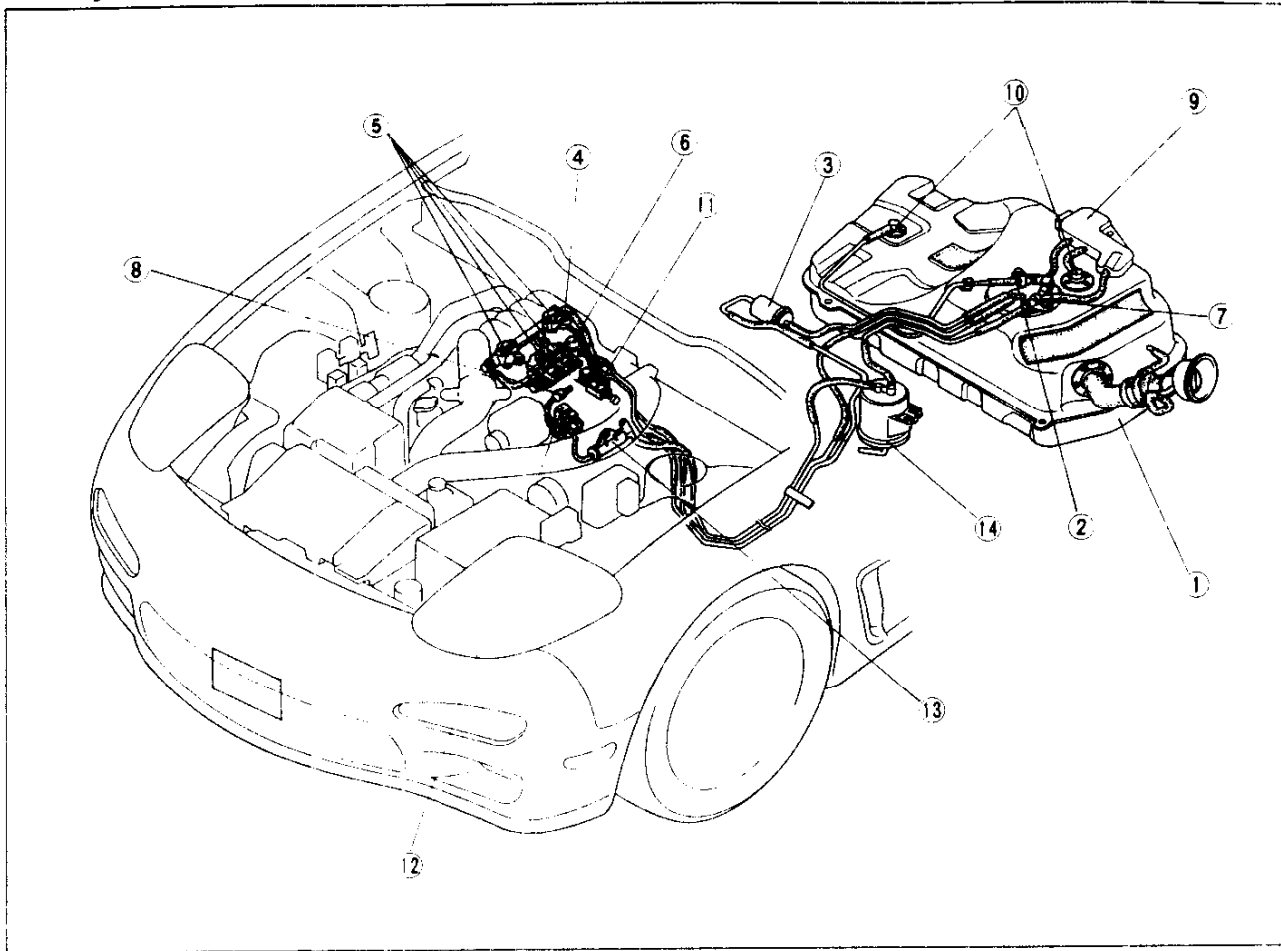

17UFX-033

- | | |
|---|---|
| <p>1. Fuel tank
Removal / Inspection /
Installation page F- 99</p> <p>2. Fuel pump
Inspection page F-100
Removal / Installation page F- 99
Disassembly / Assembly page F-102</p> <p>3. Fuel filter (High pressure)
Replacement page F-103</p> <p>4. Pressure regulator
Inspection page F-104
Removal / Installation page F-105</p> <p>5. Injector
Inspection (On vehicle) /
Removal / Installation page F-105
Inspection page F-107</p> <p>6. Pulsation damper
Removal page F-105</p> <p>7. Check valve (two way)
Inspection page F-132</p> <p>8. Check valve (one way)
Inspection page F-132</p> <p>9. Separator
Inspection page F-132</p> | <p>10. Fuel vapor valve
Inspection page F-132</p> <p>11. Solenoid valve (Pressure regulator control)
Removal / Installation page F-190
Inspection page F-191</p> <p>12. Solenoid valve (Purge control)
Removal / Installation page F-131
Inspection page F-131</p> <p>13. Catch tank
Inspection page F-132</p> <p>14. Charcoal canister
Inspection page F-131</p> |
|---|---|

Exhaust System

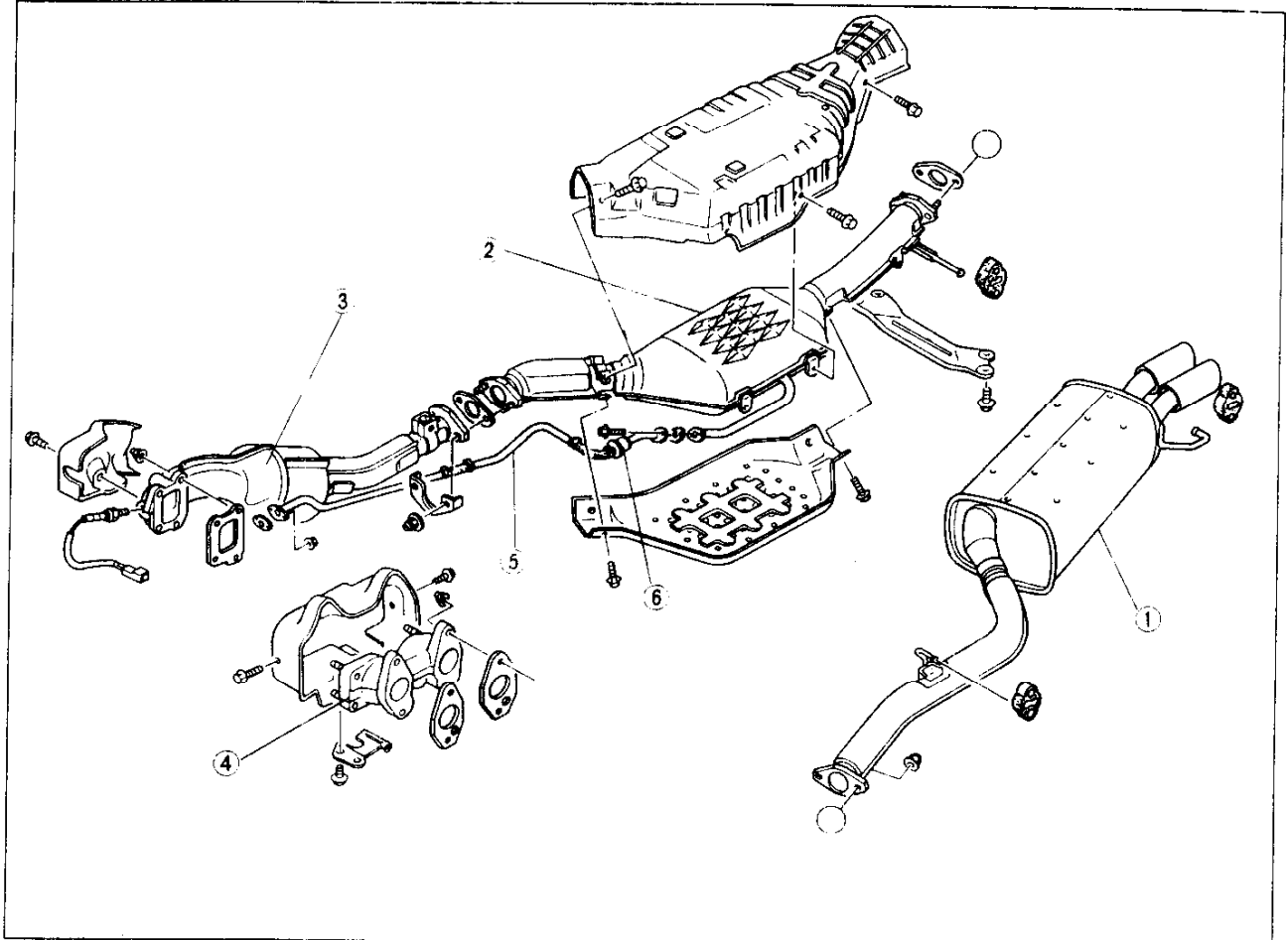

17U0FX-004

- | | |
|---|---|
| <p>1. Main silencer
Removal / Inspection /
Installation page F-113</p> <p>2. Main converter
Removal / Inspection /
Installation page F-113</p> <p>3. Front converter
Removal / Inspection /
Installation page F-113</p> | <p>4. Exhaust manifold
Removal / Inspection
Installation page F-113</p> <p>5. Secondary air pipe
Removal / Inspection /
Installation page F-113</p> <p>6. Check valve (Split air)
Inspection page F-120</p> |
|---|---|

Control System (Input Devices)

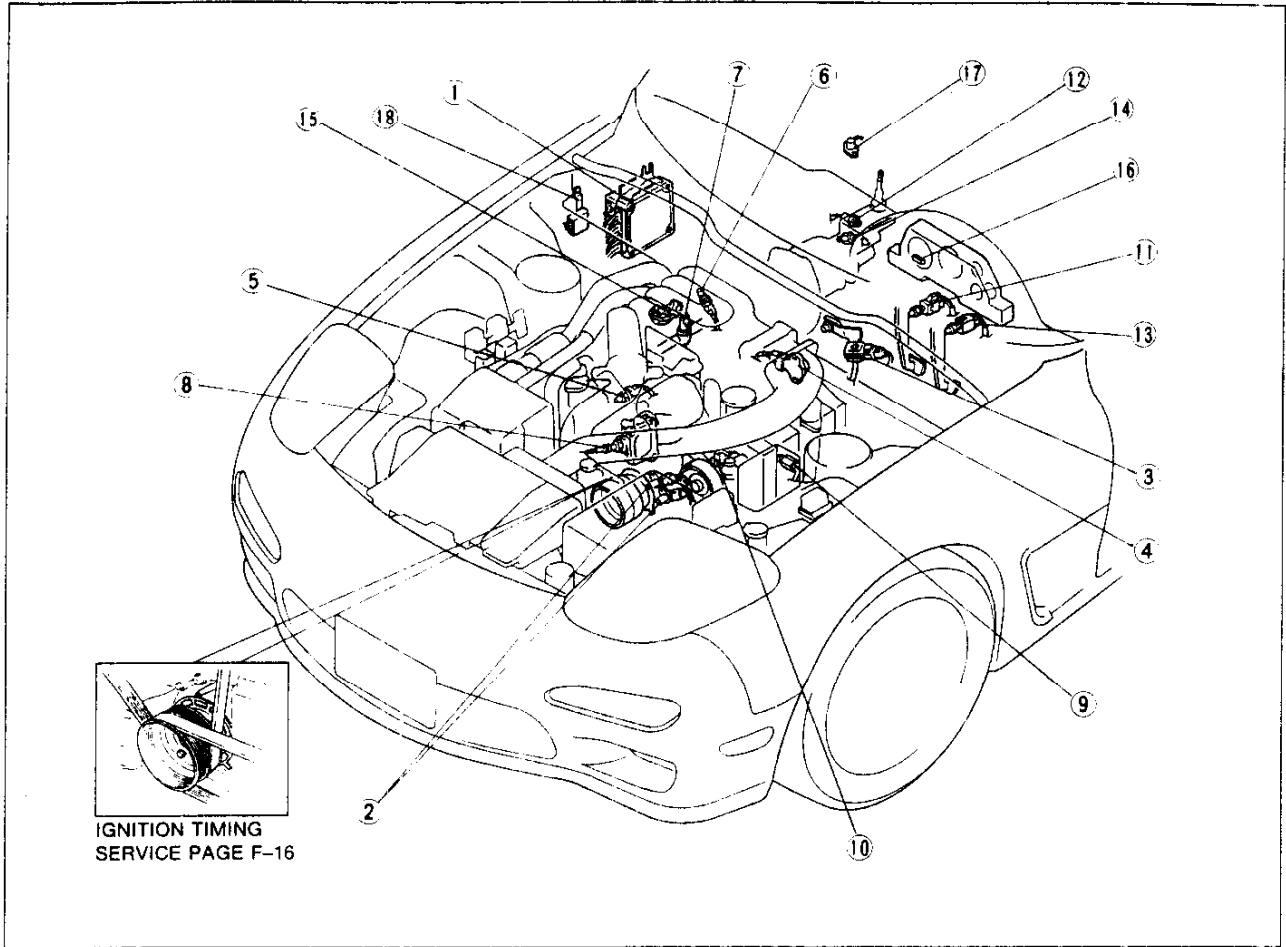

- | | |
|---|--|
| <p>1. Engine control unit (ECU)
Removal / Installation /
Inspection page F-150</p> <p>2. Crank angle sensor
Removal / Installation page F-180</p> <p>3. Pressure sensor
Inspection page F-181</p> <p>4. Throttle sensor
Inspection / Adjustment page F-182
Removal / Installation page F-183</p> <p>5. Water thermosensor
Removal / Installation /
Inspection page F-183</p> <p>6. Intake air thermosensor
Removal / Installation /
Inspection page F-183</p> <p>7. Fuel thermosensor
Removal / Installation /
Inspection page F-184</p> <p>8. Oxygen sensor
Inspection page F-184
Removal / Installation page F-113</p> <p>9. Knock sensor
Inspection (On vehicle) /
Removal / Installation page F-185</p> | <p>10. P/S pressure switch
Inspection (On vehicle) /
Removal / Installation page F-185</p> <p>11. Stoplight switch
Inspection /
Removal / Installation page F-183</p> <p>12. Neutral switch (M/T)
Inspection page F-183
Removal / Installation page F-187</p> <p>13. Clutch switch
Inspection /
Removal / Installation page F-187</p> <p>14. 1-2 switch
Inspection /
Removal / Installation page F-187</p> <p>15. EGR switch (California only)
Inspection /
Removal / Installation page F-127</p> <p>16. Mileage switch
Inspection page F-183</p> <p>17. Heat hazard sensor
Inspection /
Removal / Installation page F-189</p> <p>18. E/L unit
Inspection page F-133
Removal / Installation page F-150</p> |
|---|--|

17U0FX 035

Control System (Output Devices)

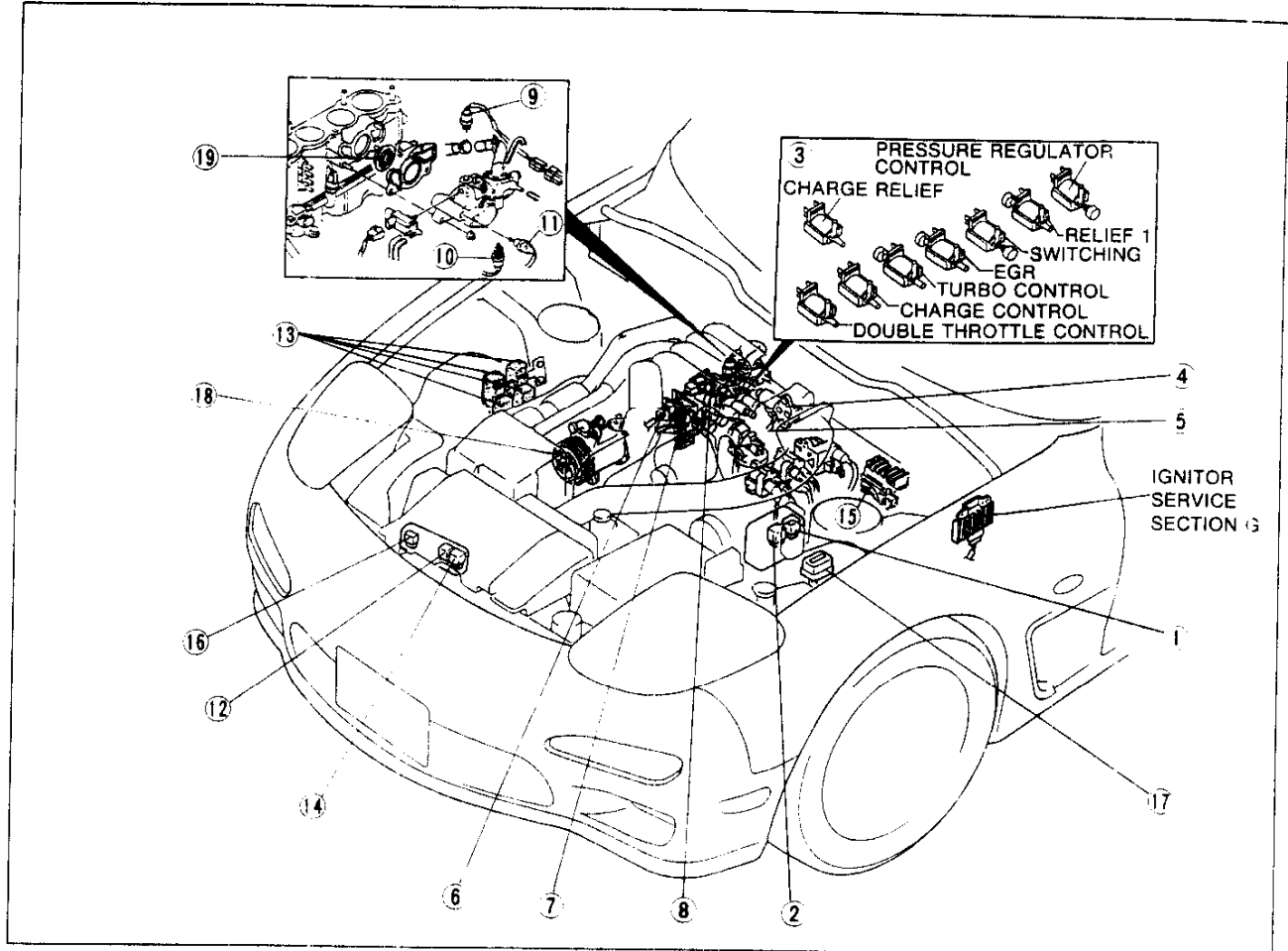

1. Main relay Inspection page F-188	10. Solenoid valve (Relief 2) Removal / Installation page F-119 Inspection page F-119
2. Circuit opening relay Inspection page F-188	11. Solenoid valve (Split air bypass) Removal / Installation page F-119 Inspection page F-120
3. Solenoid valves Removal / Installation page F-190 Inspection page F-191	12. A/C relay Inspection page F-143
4. Solenoid valve (ISC) Removal / Installation page F- 83 Inspection page F- 83	13. Cooling fan relay Inspection page F-143
5. Solenoid valve (AWS Accelerated warm-up system) Removal / Installation page F- 83 Inspection page F- 83	14. Fuel pump relay Inspection page F-110
6. Solenoid valve (Turbo precontrol) Removal / Installation page F- 93 Inspection page F- 93	15. Fuel pump resistor Removal / Installation page F-109 Inspection page F-109
7. Solenoid valve (Wastegate control) Removal / Installation page F- 93 Inspection page F- 93	16. Air pump relay Inspection page F-123
8. Solenoid valve (Turbo control) Removal / Installation page F- 93 Inspection page F- 93	17. Diagnosis connector
9. Solenoid valve (Port air bypass) Removal / Installation page F-119 Inspection page F-119	18. Air pump Inspection / Removal / Installation page F-121
	19. Check valve (Port air) Inspection page F-120

17U0FX-106

OUTLINE SYSTEM DIAGRAM

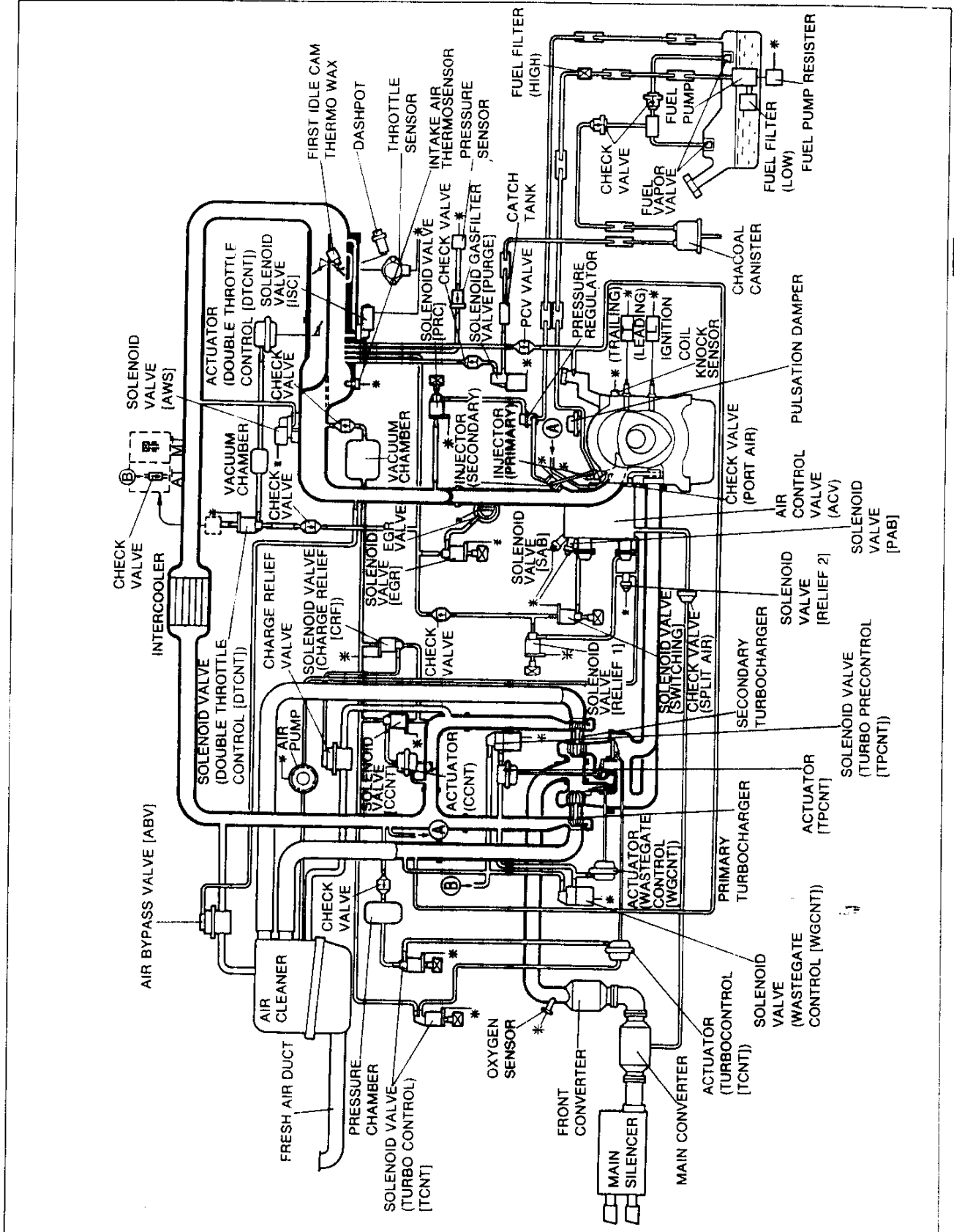

WIRING DIAGRAM

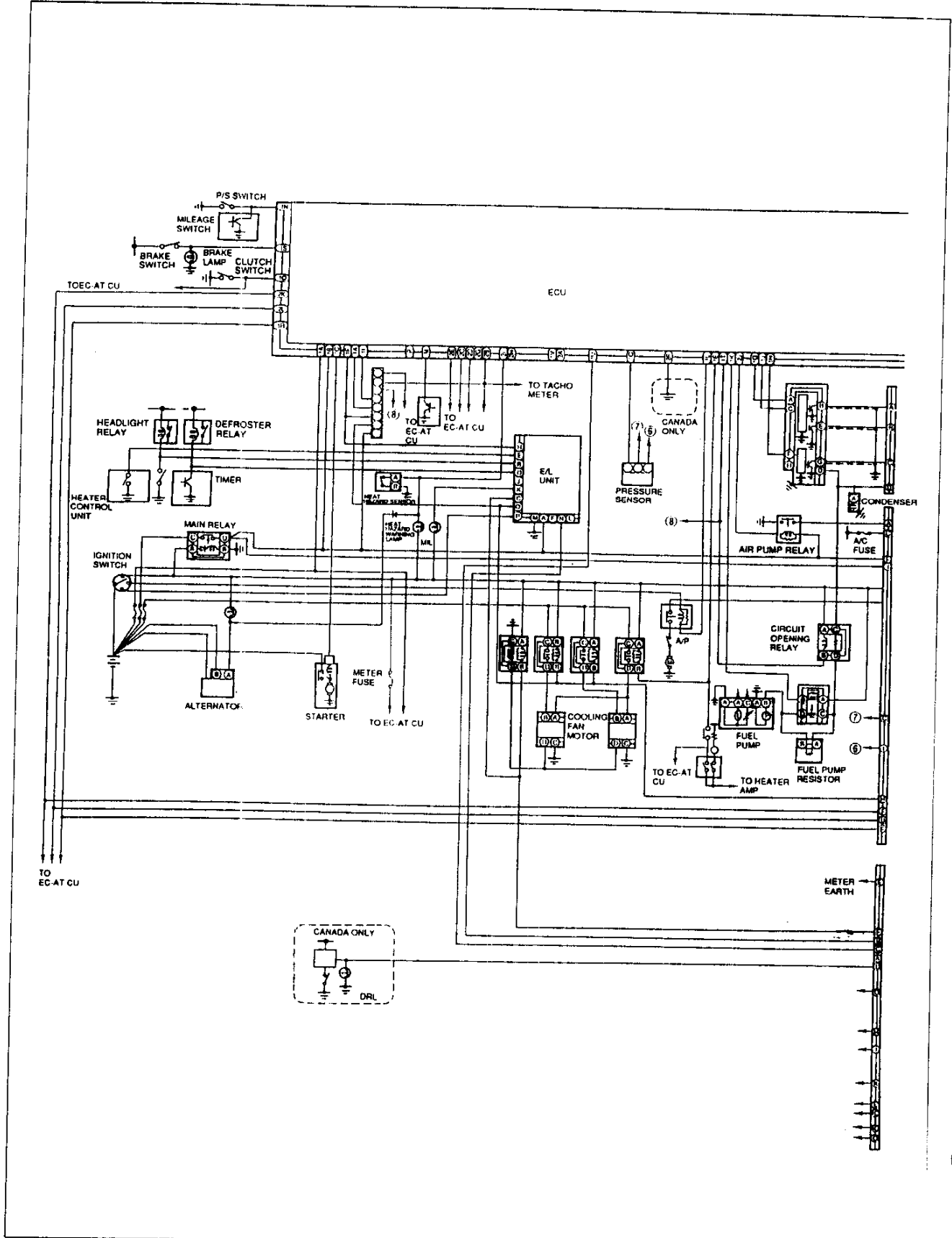

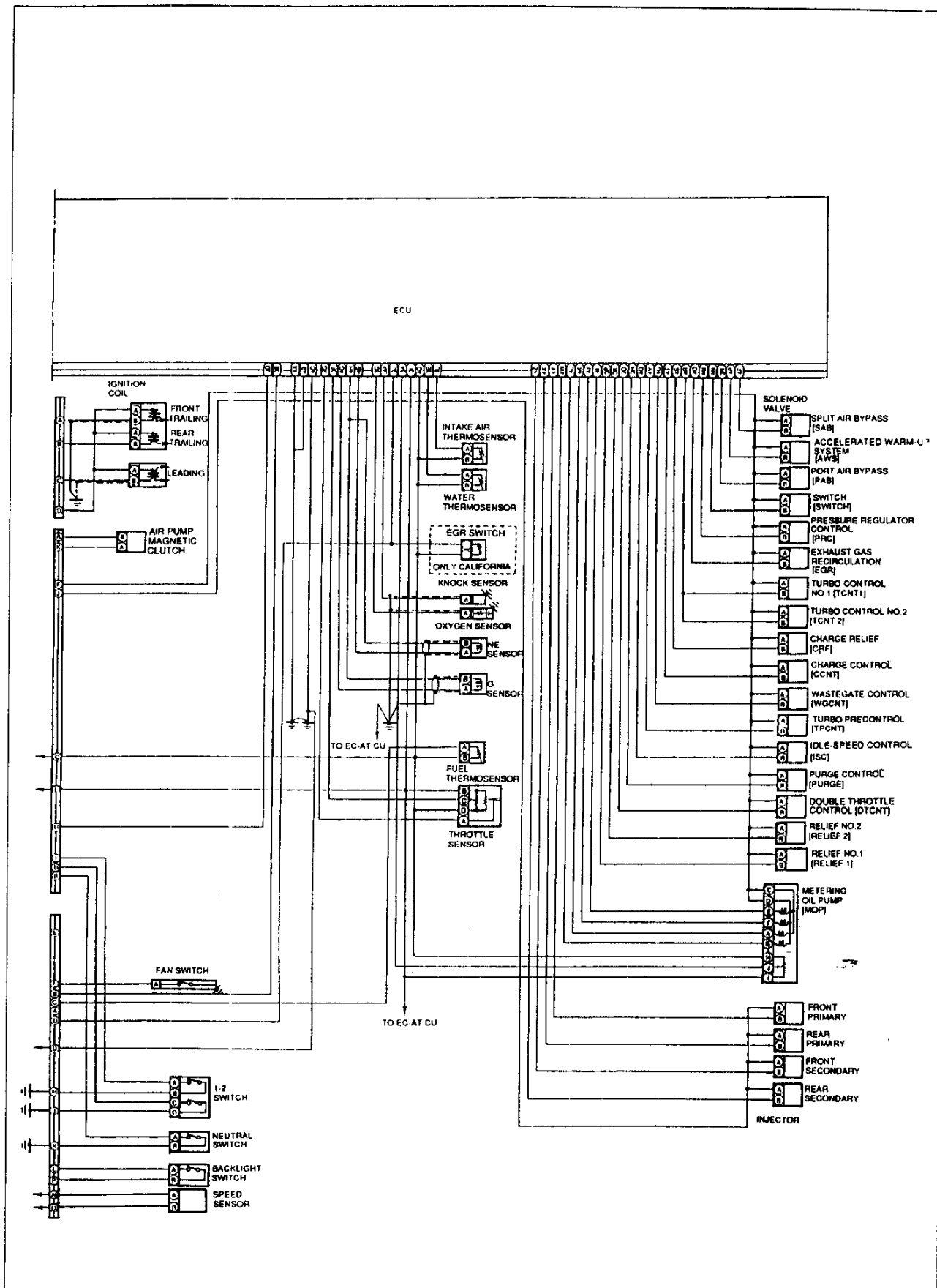

17U0FX-039

VACCUM HOSE ROUTING DIAGRAM

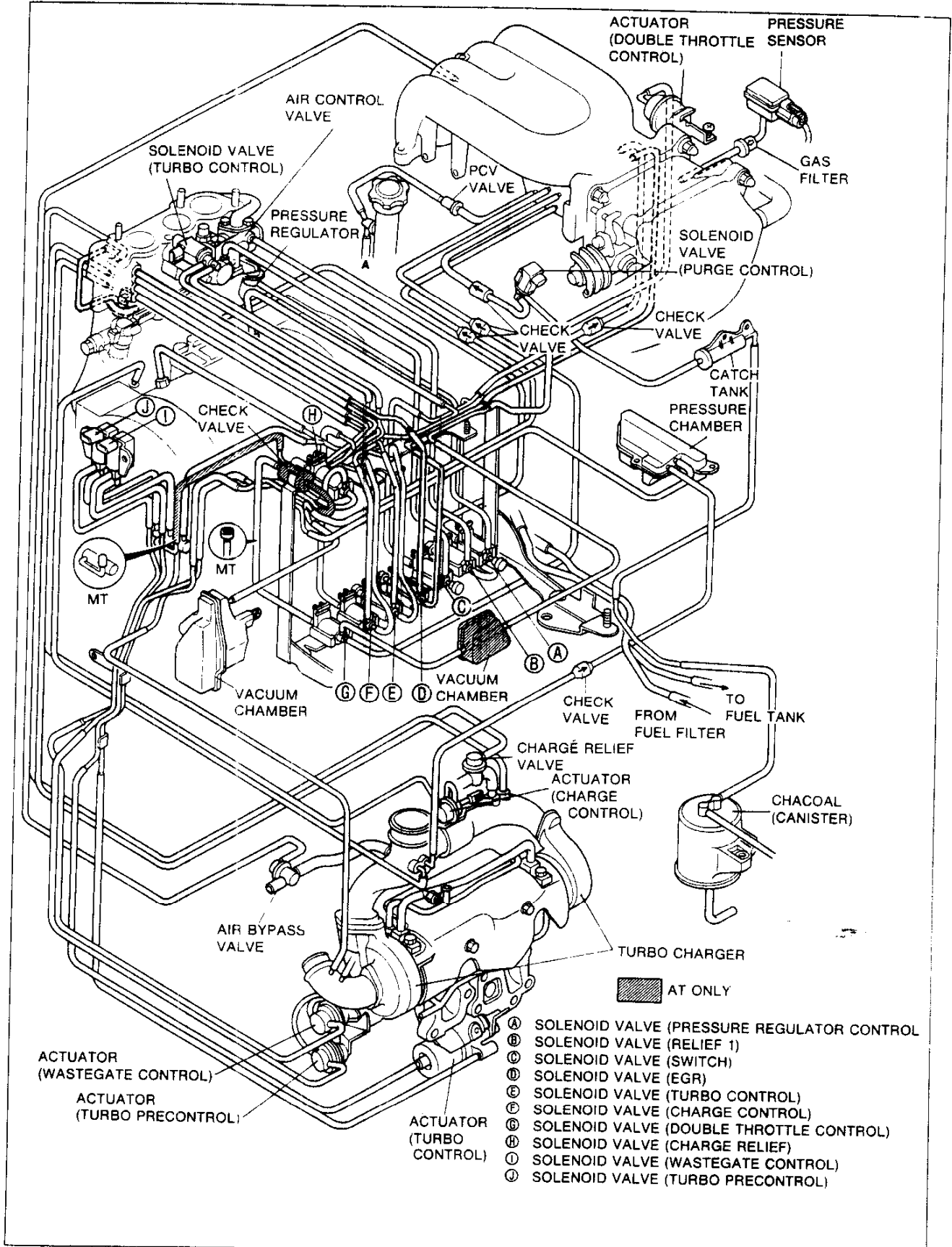

- Ⓐ SOLENOID VALVE (PRESSURE REGULATOR CONTROL)
- Ⓑ SOLENOID VALVE (RELIEF 1)
- Ⓒ SOLENOID VALVE (SWITCH)
- Ⓓ SOLENOID VALVE (EGR)
- Ⓔ SOLENOID VALVE (TURBO CONTROL)
- Ⓚ SOLENOID VALVE (CHARGE CONTROL)
- Ⓛ SOLENOID VALVE (DOUBLE THROTTLE CONTROL)
- Ⓜ SOLENOID VALVE (CHARGE RELIEF)
- Ⓝ SOLENOID VALVE (WASTEGATE CONTROL)
- Ⓟ SOLENOID VALVE (TURBO PRECONTROL)

SPECIFICATIONS

Item		Specification
Idle speed*		rpm 700-750 (720 ⁺³⁰ / ₋₂₀)
Ignition timing*	Leading	ATDC 5°
	Trailing	ATDC 20°
Air cleaner		
Element type		Oil permeated
Throttle body		
Type		Horizontal draft {2 stage-3 barrel}
Throat diameter	Primary	mm {in} 45 {1.772}
	Secondary	mm {in} 50 {1.969} × 2
Dashpot touch angle		° 8
Water thermovalve Operation (full open) temperature		°C {°F} 55-65 {131-149} or more
Intercooler		
Type		Air cooled
Core size {w × h × t}		mm {in} 294 × 114 × 65 {11.575 × 4.4882 × 2.5591}
Turbo charger		
System type		Sequential twin turbo charged
Cooling method		water + engine oil
Boost control actuator		turbo pre-control + wastegate control
Boost control method		Solenoid valve (duty-controlled) × 2
Fuel tank		
Capacity		liters {US gal, Imp gal} 76 {20.1, 16.7}
Fuel filter		
Type	Low-pressure	Nylon element
	High-pressure	paper element
Pressure regulator		
Type		Diaphragm
Regulated pressure		kPa {kgf/cm ² , psi} 250-260 {2.5-2.6, 35.6-37.0}
Fuel pump		
Type		Impeller (In tank)
Output pressure		kPa {kgf/cm ² , psi} 490-740 {5.0-7.5, 71.1-106.7}
Injector		
Type		Side-feeding
Injection volume	Primary	cm ³ {cc}/min 550 {550}
	Secondary	cm ³ {cc}/min 850 {850}
Catalytic converter		
Type	Pri-converter	Metal
	Main converter	Monolithic
Air pump		
Capacity		cm ³ {cc}/rev 375 {375}
Output		L/min MT 140-200, AT 160-200
Fuel		
Specification		Unleaded premium (RON95 or higher)

17U0FX-011

* TEN terminal of diagnosis connector is grounded.

COMPONENT DESCRIPTIONS

Component	Function	Remark
1-2 switch	Detects gear position (1st, 2nd)	MT only
Actuator (charge control)	Controls charge control valve	-
Actuator (Double throttle control)	Controls double throttle valve	Installed on extension manifold
Actuator (Turbo control)	Controls turbo control valve	Controlled by two solenoid valves
Actuator (Turbo precontrol)	Controls turbo precontrol valve	Part of turbocharger assembly
Actuator (Wastegate control)	Controls wastegate control valve	Part of turbocharger assembly
Air Bypass Valve	Reduces sound of intake air entering air cleaner from turbocharger deceleration	
Air Cleaner	Filters air entering throttle chamber	Oil permeated type
Air Control Valve	Directs air to one of three locations: exhaust port, main converter, or relief air silencer	Consists of two valves: Relief valve Switching valve
Air pump	Supplies secondary air to air control valve	With electromagnetic clutch
Atmospheric Pressure Sensor	Detects atmospheric pressure; sends signal to control unit	Built in ECU
Catalytic Converter	Reduces HC, CO and NOx	-
Charcoal Canister	Stores fuel tank fumes when engine is stopped	Vented to atmosphere through charcoal and air filter
Circuit opening relay	Voltage for fuel pump while engine running	-
Clutch switch	Detects clutch condition (engaged / disengaged)	MT only
Crank Angle Sensor	Detects eccentric shaft angle at 30° intervals and front rotor position; sends signal to control unit	-
Dashpot	Prevents sudden throttle valve closing during deceleration	-
Diagnosis connector	Service connector terminals: <ol style="list-style-type: none"> 1. EGI self-diagnosis 2. EC-AT self-diagnosis [AT] 3. Initial set 4. Fuel pump check 5. Engine speed output 6. Switch and oxygen sensor monitor 7. Supply battery voltage 8. Ground 9. A/C self-diagnosis 10. Cruise control self-diagnosis 11. Electrical cooling fan self-diagnosis 	25-pin (located near fuse box) <ol style="list-style-type: none"> 1. FEN terminal 2. TAT and FAT terminal 3. TEN terminal 4. F/P terminal 5. IG- terminal 6. MEN terminal 7. +B terminal 8. GND terminal 9. TAC and FAC terminal 10. TSC and FSC terminal 11. TFA terminal

Component	Function	Remark
<p>Engine control unit (ECU)</p>	<p>Detects the following:</p> <ol style="list-style-type: none"> 1. Engine speed 2. Knocking signal 3. Vehicle speed 4. Engine coolant temperature 5. Intake air temperature 6. Throttle valve opening angle (full range) 7. Intake manifold pressure 8. Atmospheric pressure 9. Oxygen concentration 10. Air/Fuel ratio 11. Throttle valve opening angle (narrow range) 12. Metering oil pump (MOP) position signal 13. Fuel temperature 14. Gear position 15. Clutch condition 16. In-gear condition 17. Power steering operation 18. Braking signal 19. Starter signal 20. Electrical Load (E/L) condition 21. EGR condition <p>Control operation of the following</p> <ol style="list-style-type: none"> 1. Fuel injection system 2. Ignition control system 3. Idle speed control (ISC) system 4. Pressure regulator control system 5. Secondary air injection system <ol style="list-style-type: none"> 6. Accelerated warm-up System 7. Sequential twin turbocharger control system <ol style="list-style-type: none"> 8. Exhaust Gas Recirculation control system 9. Double throttle control system 10. A/C control system 11. Electric cooling fan control system 12. Lock-up control system 13. Slip control system 14. Self-diagnosis function 15. Monitor function 16. Simulation function 17. Real-time monitor function 18. Back up function 	<ol style="list-style-type: none"> 1. Crank angle sensor 2. Knock sensor 3. Speedometer sensor 4. Water thermosensor 5. Intake air thermosensor 6. Throttle sensor (full range) 7. Pressure sensor 8. Atmospheric pressure sensor 9. Oxygen sensor 10. Oxygen sensor 11. Throttle sensor (narrow range) <ol style="list-style-type: none"> 12. MOP position sensor 13. Fuel thermosensor 14. 1-2 switch (MT) 15. Clutch switch (MT) 16. Neutral switch (MT) 17. P/S pressure switch 18. Stoplight switch 19. Ignition switch 20. E/L unit 21. EGR switch <p>Injector</p> <p>Igniter</p> <p>Solenoid valve (Idle speed control [ISC])</p> <p>Solenoid valve (Pressure Regulator control [PRC])</p> <p>Solenoid valve (Split air bypass [SAB])</p> <p>Solenoid valve (Port air bypass [PAB])</p> <p>Solenoid valve (Switch [SWITCHING])</p> <p>Solenoid valve (Relief No.2 [RELIEF2])</p> <p>Solenoid valve (Relief No.1 [RELIEF1])</p> <p>Solenoid valve (AWS)</p> <p>Solenoid valve (Turbo control No.1 [TCNT1])</p> <p>Solenoid valve (Turbo control No.2 [TCNT2])</p> <p>Solenoid valve (Wastegate control [WGCNT])</p> <p>Solenoid valve (Turbo precontrol [TPCNT])</p> <p>Solenoid valve (Change control [CCNT])</p> <p>Solenoid valve (Change relief [CRF])</p> <p>Solenoid valve (EGR)</p> <p>Solenoid valve (DTCNT)</p> <p>A/C relay</p> <p>Fan relay</p> <p>EC-AT CU</p> <p>EC-AT CU</p> <p>Self diagnosis checker or DT-S1000</p> <p>Self diagnosis checker or DT-S1000</p> <p>DT-S1000</p> <p>DT-S1000</p>

F

OUTLINE

Component	Function	Remark
Fuel filter	Filters particles from fuel	
Fuel pump	Provides fuel to injectors	<ul style="list-style-type: none"> ● Operates while engine running ● In fuel tank
Igniter	Receives spark signal from ECU and generates high voltage in ignition coil	
Ignition switch (START position)	Sends engine cranking signal to ECU	
Inhibitor switch (AT)	Detects load condition; sends signal to ECU	
Injector	Injects fuel into intake port	<ul style="list-style-type: none"> ● Controlled by signal from ECU (side-feed type)
Intake air thermosensor	Detects intake air temperature; sends signal to ECU	<ul style="list-style-type: none"> ● Installed in extension manifold
Knock sensor	Detects engine knocking; sends signal to ECU	
Main relay	Supplies current to output devices and ECU	
Neutral/Clutch switches (MT)	Detects in-gear condition; sends signal to ECU	<ul style="list-style-type: none"> ● Switch is ON in neutral
Oxygen sensor	Detects oxygen concentration; sends signal to ECU	<ul style="list-style-type: none"> ● Zirconic and platinum coat
PCV valve	Controls blowby gas introduced into engine	
Pressure regulator	Adjusts fuel pressure supply to injectors	
Pressure sensor	Detects intake manifold pressure; sends signal to ECU	
P/S pressure switch	Detects P/S operation	<ul style="list-style-type: none"> ● P/S switch ON when steering wheel turned
Pulsation dumper	Absorbs fuel pulsations	
Solenoid valve (ISC)	Supplies bypass air into intake manifold	<ul style="list-style-type: none"> ● Controlled by duty signal from ECU
Solenoid valve (PRC)	Controls vacuum to pressure regulator	<ul style="list-style-type: none"> ● Installed below extension manifold
Solenoid valve (SAB)	Controls split air volume	<ul style="list-style-type: none"> ● Installed in ACV
Solenoid valve (SWITCHING)	Controls switching valve of air control valve	<ul style="list-style-type: none"> ● Installed below extension manifold
Solenoid valve (RELIEF2)	Controls relief valve	<ul style="list-style-type: none"> ● Installed in ACV
Solenoid valve (RELEF1)	Controls relief valve	<ul style="list-style-type: none"> ● Installed below extension manifold
Solenoid valve (PAB)	Controls port air volume	<ul style="list-style-type: none"> ● Installed in ACV
Solenoid valve (AWS)	Controls accelerated warm-up system	<ul style="list-style-type: none"> ● Installed in extension manifold
Solenoid valve (TCNT1)	Controls turbo control valve	<ul style="list-style-type: none"> ● Installed in ACV (pressure applied)
Solenoid valve (TCNT2)	Controls turbo control valve	<ul style="list-style-type: none"> ● Installed below extension manifold (vacuum applied)
Solenoid valve (WGCNT)	Controls wastegate valve	<ul style="list-style-type: none"> ● Controlled by duty signal from ECU
Solenoid valve (TPCNT)	Controls turbo precontrol valve	<ul style="list-style-type: none"> ● Controlled by duty signal from ECU
Solenoid valve (CCNT)	Controls charge control valve	<ul style="list-style-type: none"> ● Installed below extension manifold
Solenoid valve (CRF)	Controls charge relief valve	<ul style="list-style-type: none"> ● Installed below extension manifold
Solenoid valve (EGR)	Controls EGR valve	<ul style="list-style-type: none"> ● Installed below extension manifold
Solenoid valve (DTCNT)	Controls double throttle valve	<ul style="list-style-type: none"> ● Installed below extension manifold
Solenoid valve (PURGE)	Controls evaporative fumes from charcoal canister to intake manifold	<ul style="list-style-type: none"> ● Controlled by duty signal from ECU
Speedometer sensor	Detects vehicle speed; sends signal to ECU	<ul style="list-style-type: none"> ● Installed in instrument cluster
Stoplight switch	Detects braking; sends signal to ECU	
Throttle body	Controls intake air amount	
Throttle sensor	Detects throttle valve opening angle	<ul style="list-style-type: none"> ● Installed on throttle body
Water thermosensor	Detect coolant temperature; send signals to ECU	<ul style="list-style-type: none"> ● Installed in engine

17U0FX-012

ENGINE TUNE-UP

PREPARATION
SST

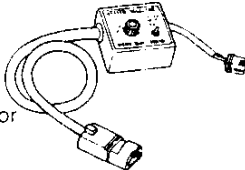
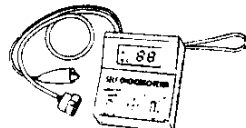
<p>49 B019 9A0 System Selector</p> 	<p>For inspection of ignition timing and idle speed and diagnosis</p>	<p>49 H018 9A1 Self Diagnosis checker</p> 	<p>For diagnosis</p>
--	---	--	----------------------

17U0FX-0-3

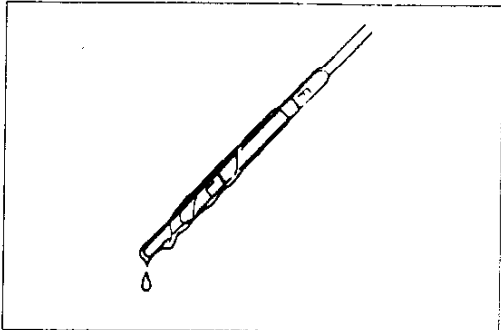

17U0FX-014

BASIC INSPECTION

Engine Oil

1. Remove the dipstick and check the engine oil level and condition.
2. Add or change oil as necessary.

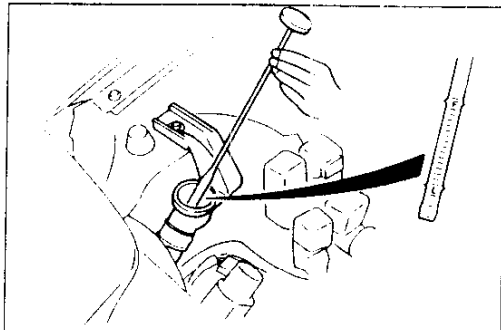

17U0FX-015

Coolant (engine cold)

Warning

- Never remove the radiator cap while the engine is hot.
- Wrap a thick cloth around the cap before carefully removing it.

1. Remove the coolant level gauge from the coolant reservoir.
2. Verify that the coolant level is between the and marks of the gauge.
3. Add coolant if necessary.

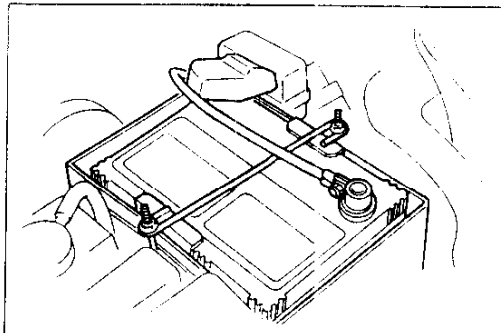

17U0FX-016

Battery

1. Check for corrosion on the terminals and for loose cable connections. If necessary, clean the clamps and tighten them firmly.
 2. Make sure the electrolyte level is between the UPPER LEVEL and LOWER LEVEL marks.
 3. Add distilled water if necessary.
4. Check the specific gravity with a hydrometer.

Gravity: 1.27–1.29 {at 20°C [68°F]}

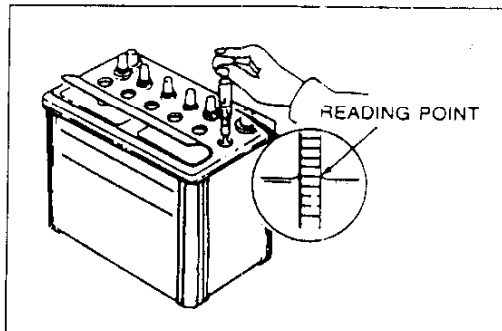

17U0FX-017

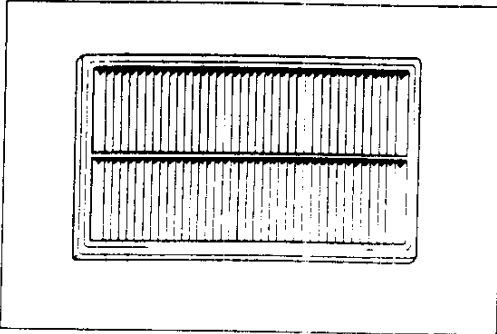

17U0FX-018

Air Cleaner Element Inspection

1. Check the air cleaner element for excessive dirt and for oil and damage.

Caution

- Do not blow the air cleaner element by compressed air to clean.

2. Replace the element if necessary.

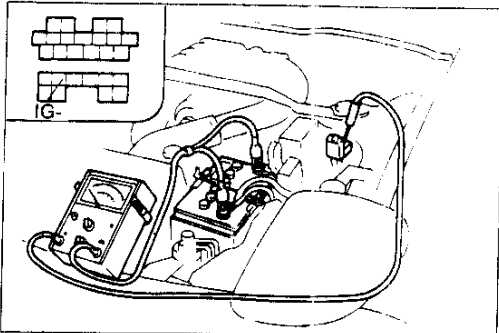

17U0FX-019

ADJUSTMENT

Preparation

1. Warm up the engine to normal operating temperature.
2. Turn all electric loads OFF.
3. Connect the **SST** to the diagnosis connector.
4. Connect a tachometer to the diagnosis connector **IG**-terminal as shown.

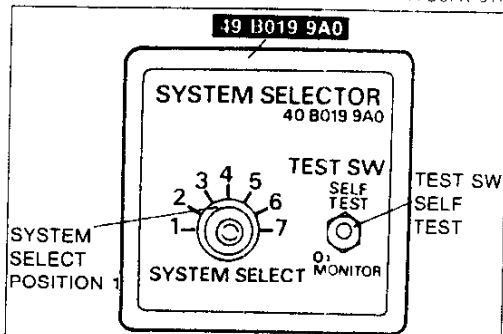

17U0FX-020

Ignition Timing

Caution

- Do not adjust the ignition timing, it is set at the factory and must not be tempered with.

1. Perform preparation (refer to above.)
2. Verify that the electric cooling fan does not operate.
3. Remove the fuel filler cap.
4. Set SYSTEM SELECT to position 1.
5. Set TEST SW to SELF-TEST.

Note

- If the **SST** is not used, jump across the **TEN** terminal and the **GND** terminal of the diagnosis connector.

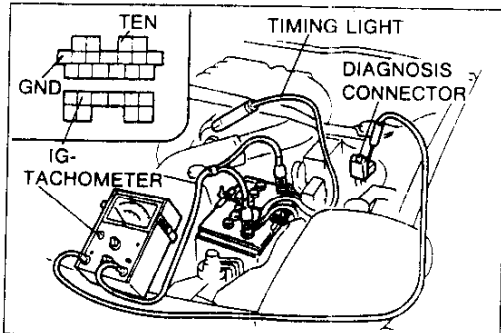

17U0FX-021

6. Make sure the idle speed is within specification; if not adjust the idle speed.
7. Connect a timing light to the high-tension lead of the front trailing-side.

Caution

- Some timing lights will not illuminate even if the ignition system is normal.

8. Verify that the timing mark (white) on the crank angle sensor plate is aligned with the indicator pin.

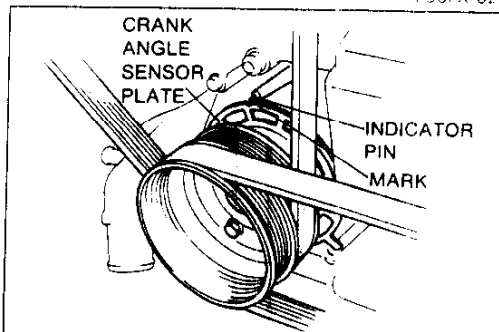

17U0FX-022

- Ignition timing: Trailing side: 20° ATDC (- 20° BTDC)**
Leading side: 5° ATDC (- 5° BTDC)
Idle speed (Neutral or P range): 550-950 rpm

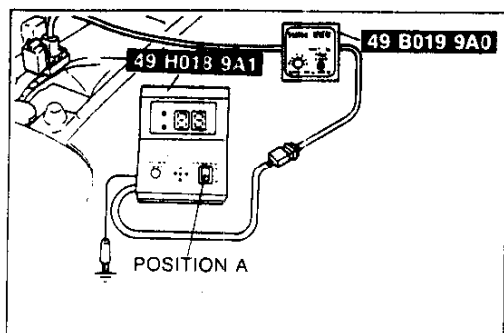

17U0FX-023

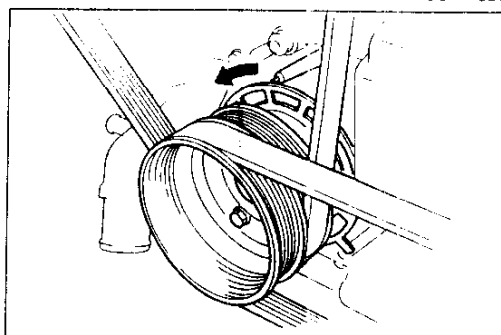

17U0FX-024

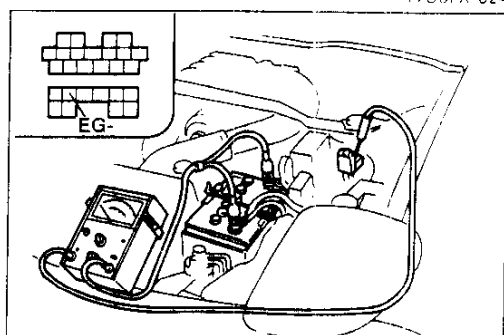

17U0FX-025

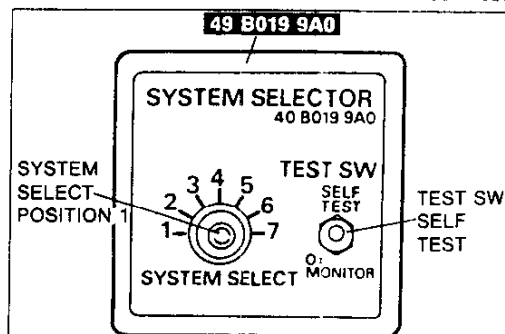

17U0FX-026

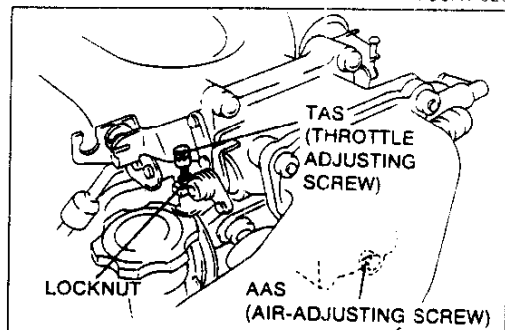

17U0FX-027

9. If the timing is incorrect, check the following procedure.
- Verify that no service code number is present. If service code number present, check for cause referring to the specified check sequence. (Refer to page F-20)
 - 05-knock sensor
 - 13-Pressure sensor

Input devices

- E/L, P/S, A/C, Cooling fan
- Crank angle sensor (NE, signal)
- Pressure sensor
- Throttle sensor
- Neutral SW / Clutch SW (MT)
- Inhibitor signal (AT)

Others

ECU terminal 3I (Refer to page F-152)

10. Disconnect the **SST**.
11. Verify that the ignition timing advances when the engine is above 1,500 RPM.

Idle Speed

Note

- Because the idle speed is controlled automatically by the ECU though the idle speed control (ISC) valve, usually it is not necessary to check and adjust the idle speed. However, the idle speed should adjust when rough idling occurs adjust the idle speed following procedure.

1. Perform "Preparation". (Refer to page F-16)
2. Set SYSTEM SELECT to position 1
3. Set TEST SW to SELF TEST
4. Verify that the idle speed is within specification.

Idle speed: 700-750 (720 ±3% rpm)

Caution

- Check the idle speed with the electric cooling fan not operating.

5. If not within the specification, adjust the idle by turning the air-adjusting screw (AAS).
6. If not within the specification when air adjusting screw fully closed, loosen the locknut and turn the throttle adjusting screw to set the idle.
7. Tighten the locknut and put a paint mark on the nut and throttle body.
8. Disconnect the **SST**.

F

SELF-DIAGNOSIS FUNCTION

SELF-DIAGNOSIS FUNCTION

DESCRIPTION

When trouble occurs in the main input or output devices, check for the cause by using the **SST**. Failure of input and output devices is indicated and retrieved from the engine control unit (ECU) as service code numbers.

Note

- The ECU constantly checks for malfunction of the input devices. But, it checks for malfunction of output devices only in a three-second period after the ignition switch is turned ON when the TEN terminal of the diagnosis connector is grounded.

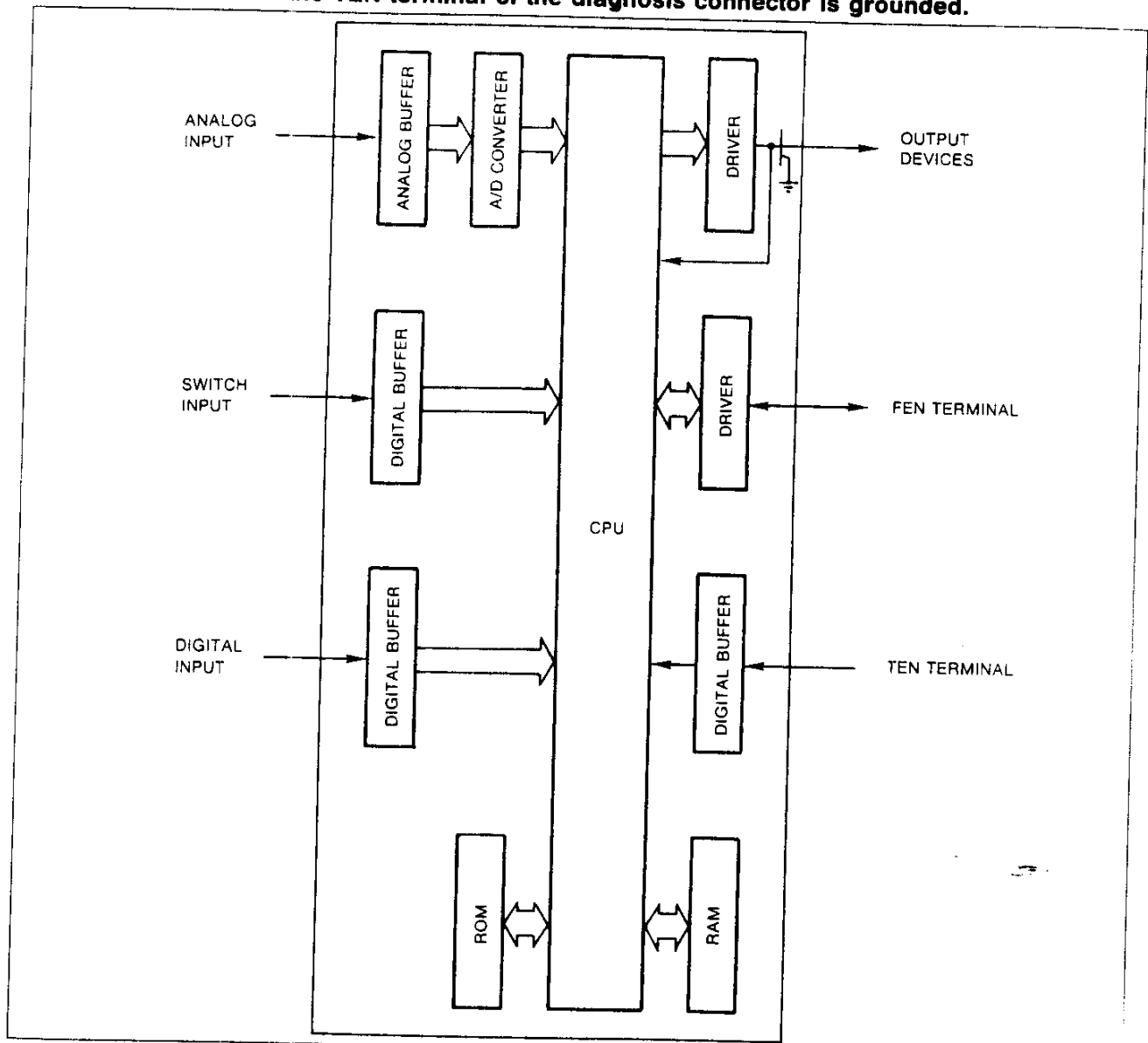

17U0FX-02F





Function

	Self diagnosis checker	DT-S1000
Service Code Number Inspection	Yes	Yes
Monitor Function	Yes	Yes
Real Time Monitor Function	No	Yes
Simulation Function	No	Yes
Memory Function (DT-S1000)	No	Yes

SELF-DIAGNOSIS FUNCTION

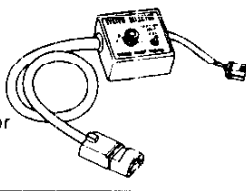
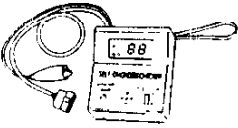
F

PREPARATION SST

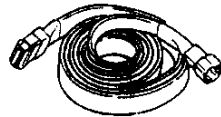
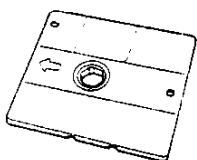
<p>49 B019 9A0 System Selector</p> 	<p>For diagnosis</p>	<p>49 H018 9A1 Self-Diagnosis Checker</p> 	<p>For diagnosis</p>
<p>49 F088 001 DT-S1000 Base unit</p> 	<p>For diagnosis</p>	<p>49 F088 002 Power unit</p> 	<p>For diagnosis</p>
<p>49 F088 003 Harness power unit</p> 	<p>For diagnosis</p>	<p>49 F088 004 Interface adapter Type-1</p> 	<p>For diagnosis</p>
<p>49 F088 005 Harness Type-1</p> 	<p>For diagnosis</p>	<p>49 F088 011 System disk Type-1 (V1.00)</p> 	<p>For diagnosis</p>

17U0FX-02

SELF-DIAGNOSIS FUNCTION

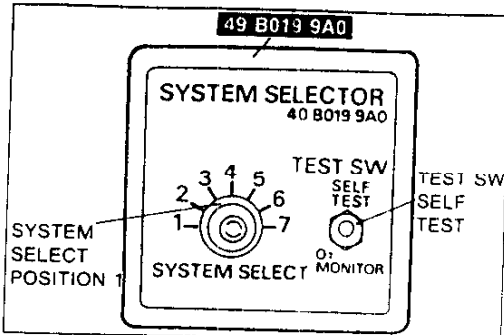

17U0FX-030

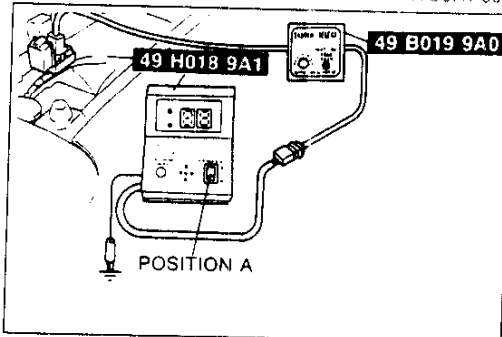

17U0FX-031

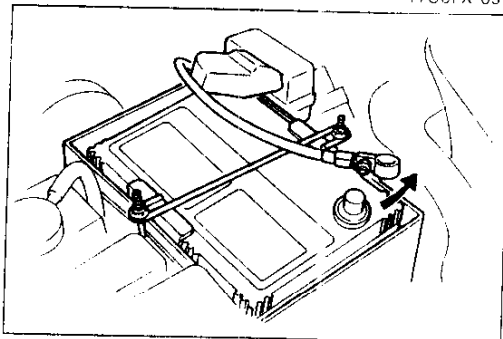

17U0FX-032

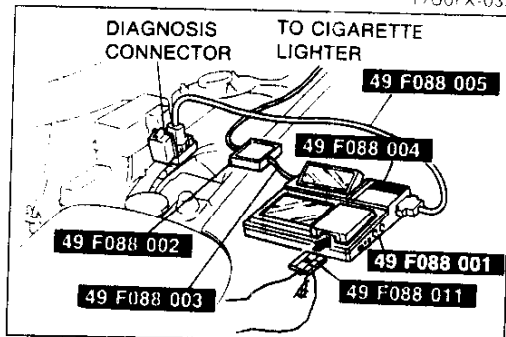

17U0FX-033

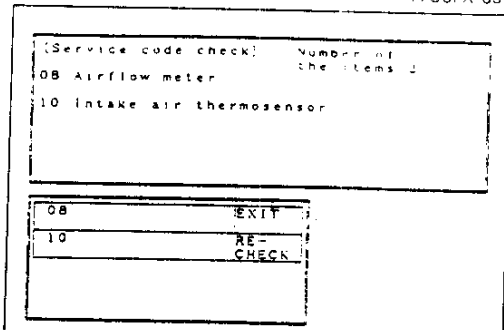

17U0FX-034

SERVICE CODE NUMBER

Inspection Procedure

1. Connect the **SST** to the Self-Diagnosis Checker to the diagnosis connector.
2. Set system select to position 1.
3. Set the test switch to SELF TEST.
4. Connect the **SST** to the System Selector and a ground.
5. Set the select switch to position A.
6. Turn the ignition switch ON.
7. Verify the "88" flashes on the digital display and the buzzer sounds for **3 sec.** after turning the ignition switch ON.
8. If "88" does not flash, check the main relay (refer to page F-188), power supply circuit, and diagnosis connector wiring.
9. If 88 flashes and the buzzer sounds continuously for more than **20 sec.**, check for a short circuit between the ECU terminal 1F and the diagnosis connector. Replace the ECU if necessary and perform Steps 3 and 7 again.
10. Note any code numbers and check for the causes by referring to the check sequences shown on pages **F-26 through F-65**. Repair as necessary.

Note

- **Cancel the code numbers by performing the after-repair procedure following repairs. (Refer to page F-66)**

DT-S1000

1. Connect the **SST** (DT-S1000) to the diagnosis connector.
2. Turn the ignition switch ON.
3. Check the service code and its cause on the **DT-S1000** display.

Note

- **If the DT-S1000 displays "No service codes", the problem will be in a system or area not covered by the self-diagnosis function.**
 - **If the DT-S1000 displays "System error", verify the DT-S1000 connection and check for the cause(s) referring to the DT-S1000 instruction manual.**
4. Note any code number(s) and check for the cause(s). Repair as necessary.

Note

- **After repairs are made, recheck for code number(s) by performing the "After-Repair Procedure." (Refer to page F-66.)**

Principle of Code Cycle

Service codes are determined as shown below.

17U0FX-035

1. Code cycle break

The time between service code cycles is 4.0 seconds (the time the buzzer is off).

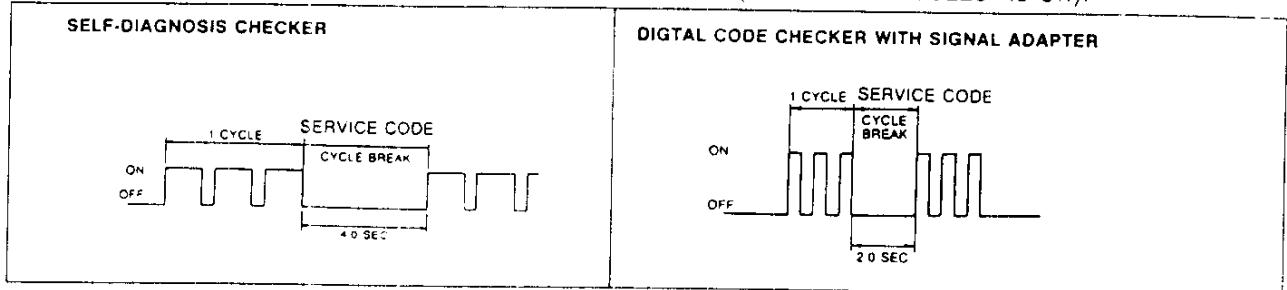

17U0FX-136

2. Second digit of service code (ones position)

The digit in the ones position of the service code represents the number of times the buzzer sounds 0.4 second during one cycle.

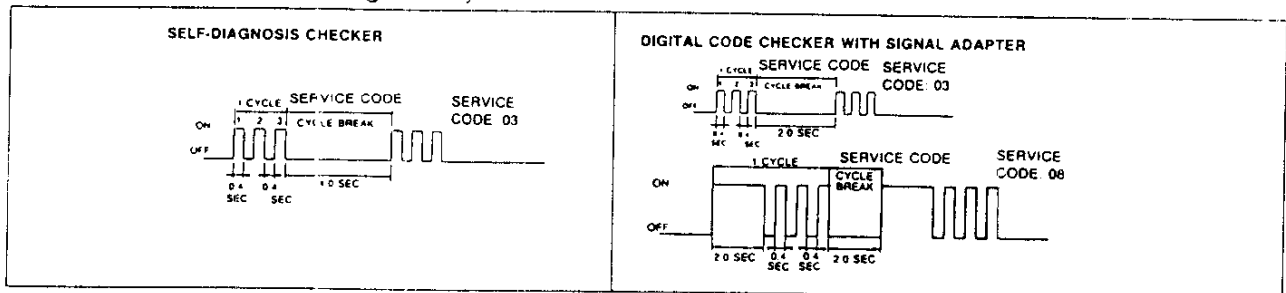

17U0FX-017

3. First digit of service code (tens position)

The digit in the tens position of the service code represents the number of times the buzzer is on 1.2 seconds during one cycle.

The buzzer is off for 1.6 seconds between the long and short pulses.

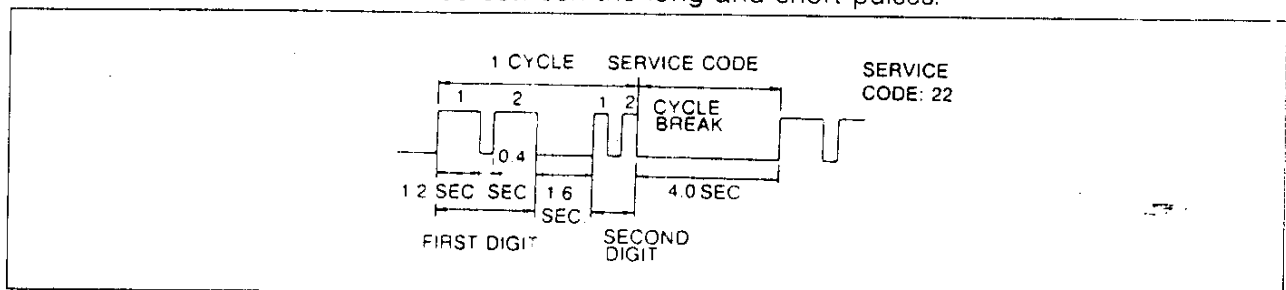









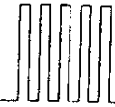

17U0FX-033

F

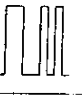

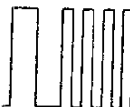
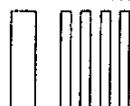







SELF-DIAGNOSIS FUNCTION

Service Code Numbers

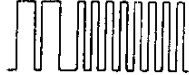
No.	Indicator flashing pattern	Diagnosed circuit	Condition	Point	Memorized	Page
02	ON OFF 	Crank angle sensor (NE signal)	No NE signal	<ul style="list-style-type: none"> ● Crank angle sensor connector ● Wiring from crank angle sensor to ECU ● Crank angle sensor 	Yes	F-26
03	ON OFF 	Crank angle sensor (G signal)	No G signal	<ul style="list-style-type: none"> ● Crank angle sensor connector ● Wiring from crank angle sensor to ECU ● Crank angle sensor 	Yes	F-27
05	ON OFF 	Knock sensor	Open or short circuit	<ul style="list-style-type: none"> ● Knock sensor connector ● Wiring from knock sensor to ECU ● Knock sensor 	Yes	F-28
06	ON OFF 	Speedometer Sensor	No speed meter sensor signal	<ul style="list-style-type: none"> ● Speedometer sensor connector ● Wiring from speedometer sensor to ECU 	Yes	F-29
09	ON OFF 	Water thermosensor	Open or short circuit	<ul style="list-style-type: none"> ● Water thermosensor connector ● Wiring from water thermosensor to ECU ● Water thermosensor resistance 	Yes	F-30
11	ON OFF 	Intake air thermosensor		<ul style="list-style-type: none"> ● Intake air thermosensor connector ● Wiring from intake air thermosensor to ECU ● Intake air thermosensor resistance 	Yes	F-31
12	ON OFF 	Throttle sensor (Full range)		<ul style="list-style-type: none"> ● Throttle sensor connector ● Wiring from throttle sensor to ECU 	Yes	F-32
13	ON OFF 	Pressure sensor		<ul style="list-style-type: none"> ● Pressure sensor connector ● Wiring from pressure sensor to ECU ● Pressure sensor resistance 	Yes	F-33
14	ON OFF 	Atmospheric pressure sensor (in ECU)		<ul style="list-style-type: none"> ● ECU 	Yes	F-34
15	ON OFF 	Oxygen sensor	Sensor output continues less than 0.55V 25 sec. in feedback zone	<ul style="list-style-type: none"> ● Oxygen sensor connector ● Wiring from oxygen sensor to ECU ● Oxygen sensor 	Yes	F-34
16	ON OFF 	EGR switch (California only)	Open or short circuit	<ul style="list-style-type: none"> ● EGR switch connector ● Wiring from EGR switch to ECU ● EGR switch 	Yes	F-35
17	ON OFF 	Feedback system	Sensor output not changed 120 sec. in feedback zone	<ul style="list-style-type: none"> ● Fuel pressure ● Injection fuel leakage ● Ignition system ● Air leakage ● ECU 	Yes	F-36
18	ON OFF 	Throttle sensor (Narrow range)	Open or short circuit	<ul style="list-style-type: none"> ● Throttle sensor connector ● Wiring from throttle sensor to ECU 	Yes	F-38









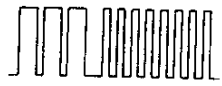

SELF-DIAGNOSIS FUNCTION

F

No.	Indicator flashing pattern	Diagnosed circuit	Condition	Point	Memo-rized	Page	
20	ON OFF 	Metering oil pump position sensor	Open or Short circuit	<ul style="list-style-type: none"> ● MOP connector ● Wiring from MOP position sensor to ECU ● MOP position sensor continuity 	Yes	F-33	
23	ON OFF 	Fuel thermosensor		<ul style="list-style-type: none"> ● Fuel thermosensor connector ● Wiring from Fuel thermosensor to ECU ● Fuel thermosensor resistance 	Yes	F-40	
25	ON OFF 	Solenoid valve (pressure regulator control)		<ul style="list-style-type: none"> ● Solenoid valve connector ● Wiring from solenoid valve to ECU ● Solenoid valve continuity 	No	F-41	
26	ON OFF 	Metering oil pump (stepping moter)		<ul style="list-style-type: none"> ● MOP connector ● Wiring from MOP to ECU ● MOP continuity 	No	F-42	
27	ON OFF 	Metering oil pump	Open or short circuit or Sticking of MOP sensor	<ul style="list-style-type: none"> ● MOP connector ● Wiring from MOP to ECU ● Mop continuity 	Yes	F-43	
28	ON OFF 	Solenoid valve (EGR)	Open or short circuit	<ul style="list-style-type: none"> ● Solenoid valve connector ● Wiring from solenoid valve to ECU ● Solenoid valve continuity 	No	F-44	
30	ON OFF 	Solenoid valve (Split air bypass)		<ul style="list-style-type: none"> ● Solenoid valve connector ● Wiring from solenoid valve to ECU ● Solenoid valve continuity 	No	F-45	
31	ON OFF 	Solenoid valve (Relief 1)		<ul style="list-style-type: none"> ● Solenoid valve connector ● Wiring from solenoid valve to ECU ● Solenoid valve continuity 	No	F-46	
32	ON OFF 	Solenoid valve (Switching)		<ul style="list-style-type: none"> ● Solenoid valve connector ● Wiring from solenoid valve to ECU ● Solenoid valve continuity 	No	F-47	
33	ON OFF 	Solenoid valve (Port air bypass)		<ul style="list-style-type: none"> ● Solenoid valve connector ● Wiring from solenoid valve to ECU ● Solenoid valve continuity 	No	F-48	
34	ON OFF 	Solenoid valve (Idle speed control)		<ul style="list-style-type: none"> ● Solenoid valve connector ● Wiring from solenoid valve to ECU ● Solenoid valve continuity 	No	F-49	
37	ON OFF 	Metering Oil Pump		Low battery voltage	<ul style="list-style-type: none"> ● Charging system ● MOP connector ● Wiring from MOP to ECU 	Yes	F-50







F

SELF-DIAGNOSIS FUNCTION

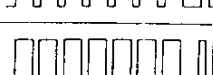
No.	Indicator flashing pattern	Diagnosed circuit	Condition	Point	Memo-rized	Page
38	ON OFF 	Solenoid valve (Accelerated warm-up system)	Open or Short Circuit	<ul style="list-style-type: none"> ● Solenoid valve connector ● Wiring from Solenoid valve to ECU ● Solenoid valve continuity 	No	F-51
39	ON OFF 	Solenoid valve (Relief 2)		<ul style="list-style-type: none"> ● Solenoid valve connector ● Wiring from Solenoid valve to ECU ● Solenoid valve continuity 	No	F-52
40	ON OFF 	Solenoid valve (Purge control)		<ul style="list-style-type: none"> ● Solenoid valve connector ● Wiring from Solenoid valve to ECU ● Solenoid valve continuity 	No	F-53
42	ON OFF 	Solenoid valve (Turbo precontrol)		<ul style="list-style-type: none"> ● Solenoid valve connector ● Wiring from Solenoid valve to ECU ● Solenoid valve continuity 	No	F-54
43	ON OFF 	Solenoid valve (Wastegate control)		<ul style="list-style-type: none"> ● Solenoid valve connector ● Wiring from Solenoid valve to ECU ● Solenoid valve continuity 	No	F-55
44	ON OFF 	Solenoid valve (Turbo control)		<ul style="list-style-type: none"> ● Solenoid valve connector ● Wiring from Solenoid valve to ECU ● Solenoid valve continuity 	No	F-56
45	ON OFF 	Solenoid valve (Charge control)		<ul style="list-style-type: none"> ● Solenoid valve connector ● Wiring from Solenoid valve to ECU ● Solenoid valve continuity 	No	F-57
46	ON OFF 	Solenoid valve (Charge relief)		<ul style="list-style-type: none"> ● Solenoid valve connector ● Wiring from Solenoid valve to ECU ● Solenoid valve continuity 	No	F-58
50	ON OFF 	Solenoid valve (Double throttle control)		<ul style="list-style-type: none"> ● Solenoid valve connector ● Wiring from Solenoid valve to ECU ● Solenoid valve continuity 	No	F-59
51	ON OFF 	Fuel pump relay		<ul style="list-style-type: none"> ● Fuel pump relay connector ● Wiring from relay to ECU ● Relay continuity 	No	F-60
54	ON OFF 	Air pump relay	<ul style="list-style-type: none"> ● Air pump relay connector ● Wiring from relay to ECU ● Relay continuity 	No	F-61	

SELF-DIAGNOSIS FUNCTION

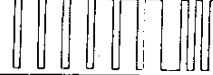
F

No.	Indicator flashing pattern	Diagnosed circuit	Condition	Point	Memo- rized	Page
71	ON 	Injector (Front secondary)	Open circuit	<ul style="list-style-type: none"> ● Injector connector ● Wiring from Injector to ECU ● Injector resistance 	No	F-62
	OFF 					
73	ON 	Injector (Rear secondary)	Open circuit	<ul style="list-style-type: none"> ● Injector connector ● Wiring from injector to ECU ● Injector resistance 	No	F-63
	OFF 					
76	ON 	Slip Lock up off Signal (EC-AT CU)	Open or Short circuit	<ul style="list-style-type: none"> ● EC-AT CU connector ● Wiring from EC-AT CU to ECU 	No	F-64
	OFF 					
77	ON 	Torque reduced signal (EC-AT CU)	Open or Short circuit	<ul style="list-style-type: none"> ● EC-AT CU connector ● Wiring from EC-AT CU to ECU 	No	F-65
	OFF 					

37U0F-039

Caution

- If more than one failure is present, the code numbers will be indicated in numerical order, lowest number first.
- After repairing a failures, turn off the ignition switch and disconnect the negative battery cable for 20 seconds and depress the brake pedal to erase the service code(s) from the ECU memory.

F

SELF-DIAGNOSIS FUNCTION

CODE No.	05 (KNOCK SENSOR)		
STEP	INSPECTION	ACTION	
1	Does knock sensor circuit have a poor connection?	Yes	Repair connector and/or wiring harness
		No	Go to next step
2	Is there continuity between knock sensor and ECU terminal 3M (W)?	Yes	Check continuity between ECU terminal 3M (W) and ground ⇨ If continuity, repair or replace wiring ⇨ If no continuity, go to next step
		No	Repair wiring harness
3	Try known good knock sensor, is same code No. present?	Yes	Replace ECU ⇨ page F-180
		No	Replace knock sensor ⇨ page F-185

Circuit Diagram

17U0FX-142

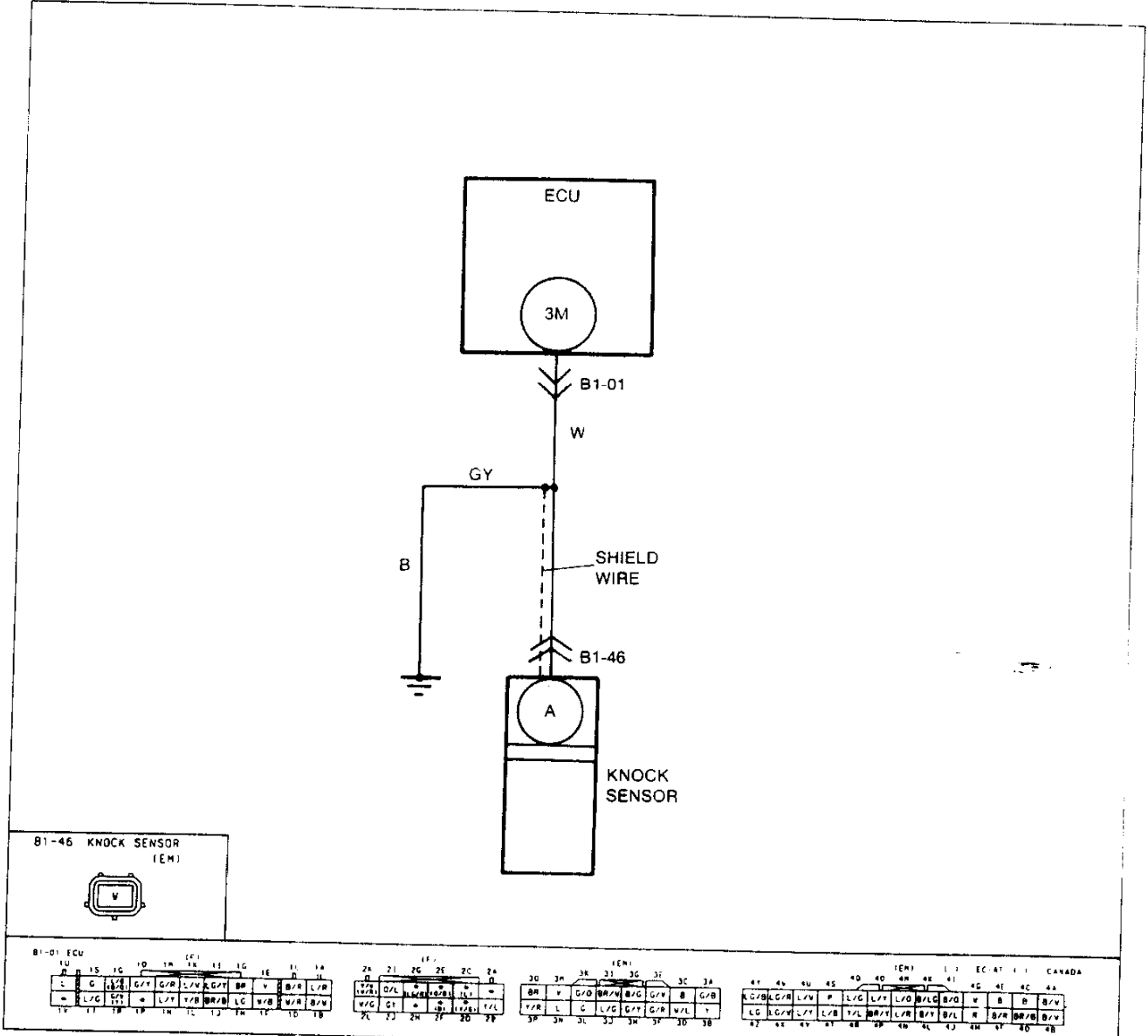

16E0F2-041

SELF-DIAGNOSIS FUNCTION

F

CODE No.	06 (SPEEDOMETER SENSOR)							
STEP	INSPECTION	ACTION						
1	Is speedometer working correctly	Yes	Go to next step					
		No	Go to step 5					
2	Check for EC-AT CU service code. Is code No.07 also present?	Yes	Go to step 5					
		No	Go to next step					
3	Does speedometer sensor circuit have a poor connection?	Yes	Repair connector and/or wiring harness					
		No	Go to next step					
4	Is there speedometer sensor terminal 1M (G/R) voltage OK?	Yes	Check for open or short circuit wiring harness (Speedometer sensor terminal 3E (G/R)-ECU terminal 1M)					
		No	Replace speedometer					
<table border="1" style="margin: auto; border-collapse: collapse;"> <thead> <tr> <th style="text-align: center;">Condition</th> <th style="text-align: center;">Voltage</th> </tr> </thead> <tbody> <tr> <td style="text-align: center;">While driving</td> <td style="text-align: center;">2-3V</td> </tr> <tr> <td style="text-align: center;">Idle</td> <td style="text-align: center;">4-5V</td> </tr> </tbody> </table>		Condition	Voltage	While driving	2-3V	Idle	4-5V	If OK go to step 8 If not OK, repair wiring harness.
Condition	Voltage							
While driving	2-3V							
Idle	4-5V							
5	Remove speed sensor Is resistance felt when turning speedometer driven gear by hand?	Yes	Go to next step					
		No	Replace speed sensor					
6	Disconnect speed sensor connector and connect circuit tester Does pointer of circuit tester move slightly when driven gear is slowly turned?	Yes	Go to next step					
		No	Replace speed sensor					
7	Disconnect speed sensor connector Is continuity of sensor OK? Resistance: Approx. 290 Ω (20°C [68°F]); (reference)	Yes	Check wiring and connectors from speed sensor to speedometer					
		No	Replace speed sensor					
8	Disconnect negative battery cable for at least 20 seconds Connect battery cable and recheck for service code Is service code displayed?	Yes	Replace ECU ☞ page F-150					
		No	Intermittent poor connection Check for cause					

17U0FK-043

Circuit Diagram

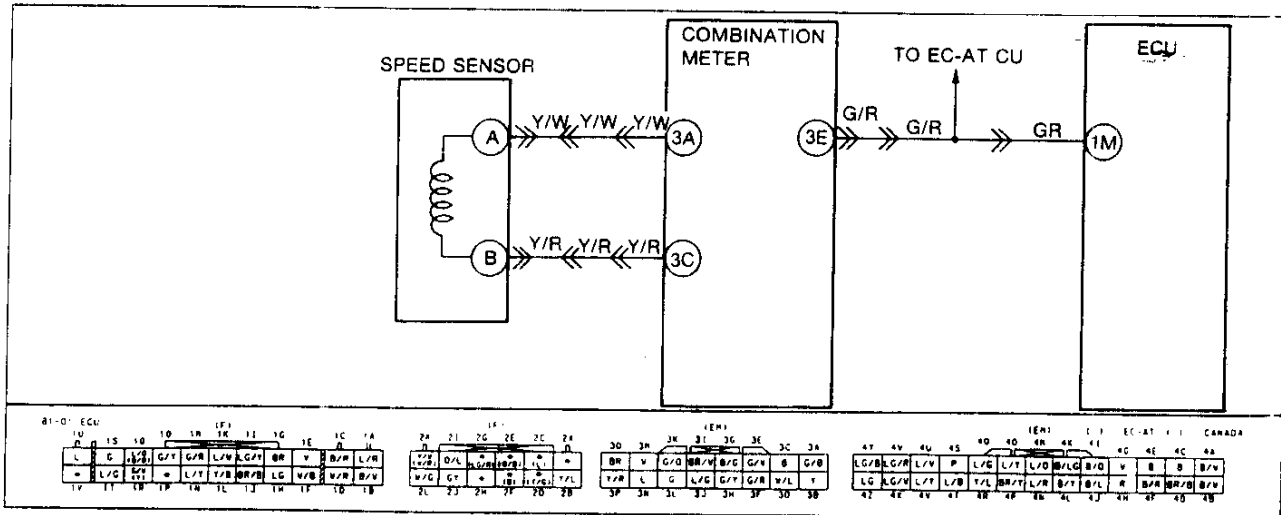

F

SELF-DIAGNOSIS FUNCTION

CODE No.		09 (WATER THERMOSENSOR)	
STEP	INSPECTION	ACTION	
1	Does the water thermosensor circuit have a poor connection?	Yes	Repair connector and/or wiring harness
		No	Go to next step
2	Is water thermosensor terminal (G/W) Voltage OK with water thermosensor connector disconnected?	Yes	Go to next step
		No	Check for short or open circuit in wiring harness (Water thermosensor terminal [G/W]-ECU terminal 3E) ➡ If OK, replace ECU ➡ If not OK, repair wiring harness
3	Is there continuity between water thermosensor terminal (BR/B) and a ground	Yes	Go to next step
		No	Repair wiring harness
4	Is resistance of water thermosensor OK?	Yes	Replace ECU ☞ page F-156
		No	Replace water thermosensor ☞ page F-183

Condition	Voltage
Ignition switch ON	Approx. 5.0V

Coolant temp.	Resistance (kΩ)
-20°C (-4°F)	14.6-17.8
20°C (68°F)	2.2-2.7
80°C (176°F)	0.29-0.35

17U0FX-144

Circuit Diagram

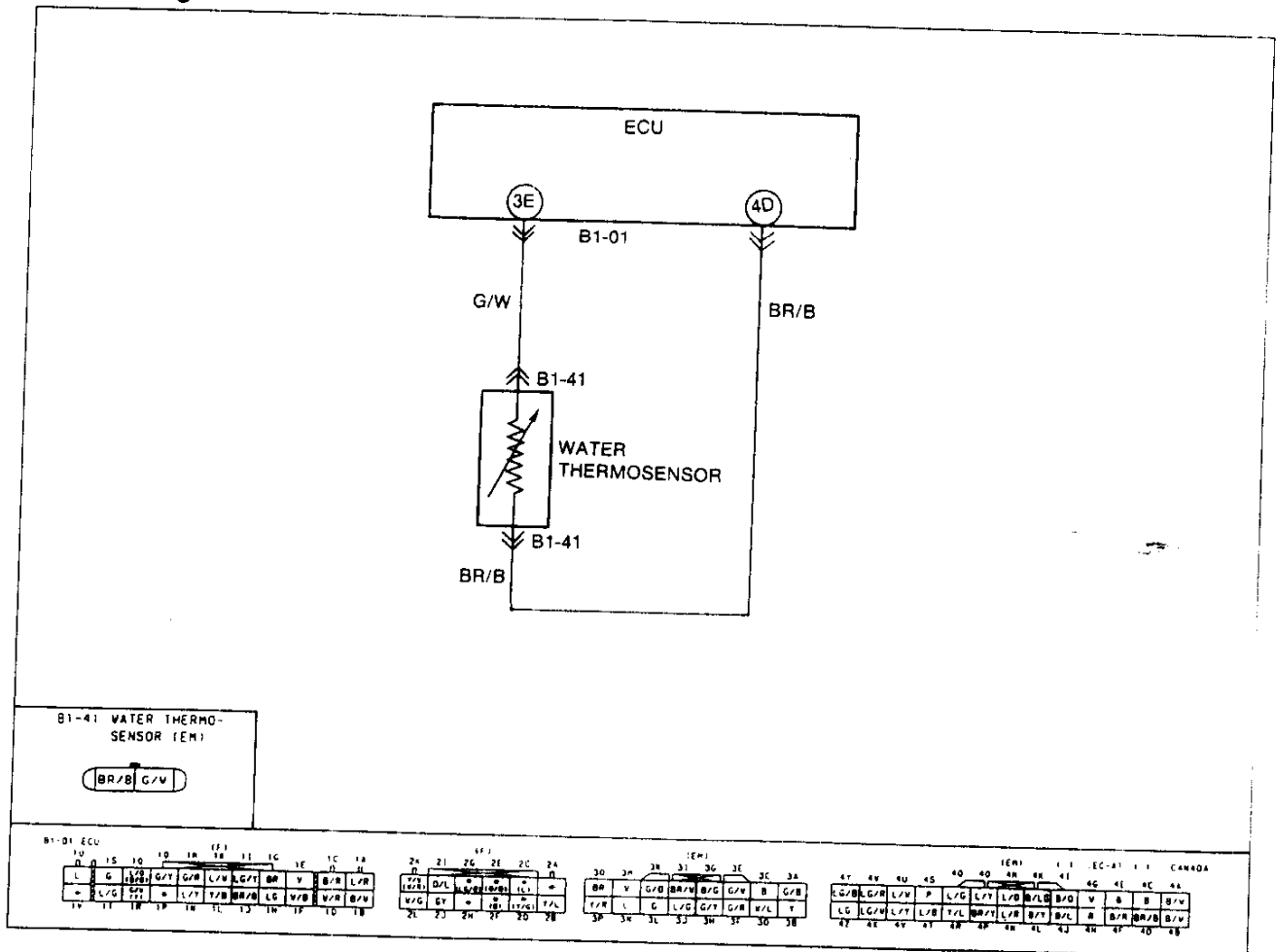

16E0F2-045

F

SELF-DIAGNOSIS FUNCTION

CODE No.	12 (THROTTLE SENSOR [FULL RANGE])								
STEP	INSPECTION	ACTION							
1	Does throttle sensor circuit have a poor connection?	Yes	Repair connector and/or wiring harness						
		No	Go to next step						
2	Is throttle sensor terminal (BR/W) voltage OK with throttle sensor disconnected? <table border="1" style="width: 100%;"> <thead> <tr> <th>Condition</th> <th>Voltage</th> </tr> </thead> <tbody> <tr> <td>Ignition switch ON</td> <td>Approx. 5.0V</td> </tr> </tbody> </table>	Condition	Voltage	Ignition switch ON	Approx. 5.0V	Yes	Go to next step		
		Condition	Voltage						
Ignition switch ON	Approx. 5.0V								
No	Check for open or short circuit in wiring harness (Throttle sensor terminal [BR/W]-ECU terminal 3I) ↳ If OK, replace ECU ↳ If not OK, repair wiring harness								
3	Is there continuity between throttle sensor and ECU? <table border="1" style="width: 100%;"> <thead> <tr> <th>Throttle sensor</th> <th>ECU</th> </tr> </thead> <tbody> <tr> <td>(B/G)</td> <td>3G (B/G)</td> </tr> <tr> <td>(BR/B)</td> <td>4D (BR/B)</td> </tr> </tbody> </table>	Throttle sensor	ECU	(B/G)	3G (B/G)	(BR/B)	4D (BR/B)	Yes	Check for short circuit in wiring harness (Throttle sensor terminal (B/G)-ECU terminal 3G) ↳ If OK, go to next step ↳ If not OK, repair wiring harness
		Throttle sensor	ECU						
(B/G)	3G (B/G)								
(BR/B)	4D (BR/B)								
No	Repair wiring harness								
4	Is there continuity between terminals (BR/W) and (B/G) with throttle valve fully closed to fully opened OK?	Yes	Replace ECU ↗ page F-150						
		No	Replace throttle sensor ↗ page F-182						

17U0FX-146

Circuit Diagram

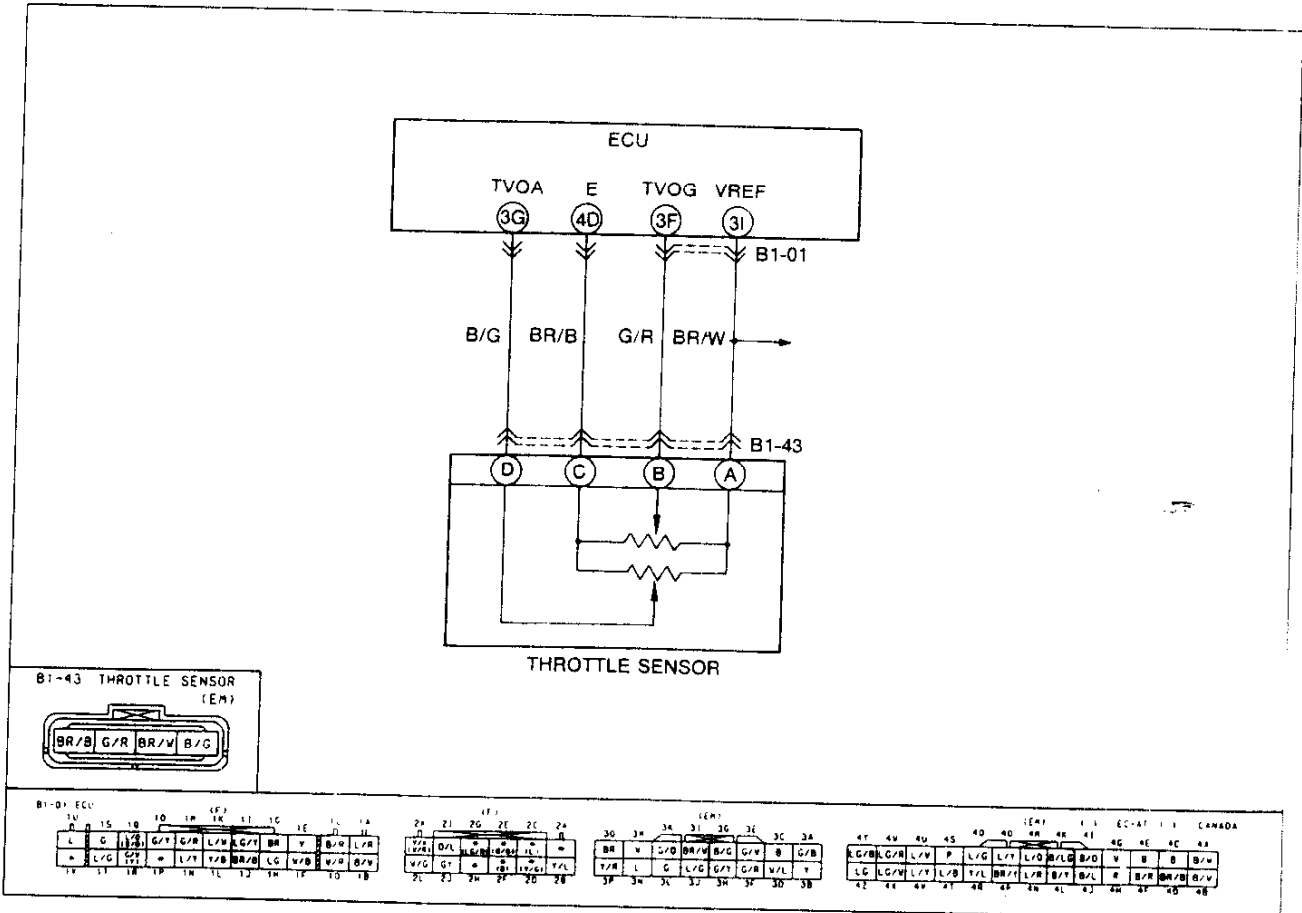

SELF-DIAGNOSIS FUNCTION

F

CODE No.	13 (PRESSURE SENSOR)								
STEP	INSPECTION	ACTION							
1	Does pressure sensor circuit have a poor connection?	Yes	Repair connector and/or wiring harness						
		No	Go to next step						
2	Is connector terminal (BR/W) voltage OK with pressure sensor connector disconnected?	Yes	Go to next step						
		No	Check for open or short circuit in wiring harness (pressure sensor terminal [BR/W] ECU relay terminal [BR/W])						
3	Is there continuity between pressure sensor terminal (BR/B) and ECU terminal 4D	Yes	Go to next step						
		No	Repair wiring harness						
4	Is output voltage (G/Y) of pressure sensor OK?	Yes	Replace ECU ↪ page F-150						
		<table border="1" style="width: 100%; border-collapse: collapse;"> <thead> <tr> <th style="text-align: center;">Condition</th> <th style="text-align: center;">Voltage</th> </tr> </thead> <tbody> <tr> <td style="text-align: center;">Ignition switch ON</td> <td style="text-align: center;">Approx. 5V</td> </tr> </tbody> </table>		Condition	Voltage	Ignition switch ON	Approx. 5V		
		Condition	Voltage						
		Ignition switch ON	Approx. 5V						
No	Replace pressure sensor ↪ page F-181								
<table border="1" style="width: 100%; border-collapse: collapse;"> <thead> <tr> <th style="text-align: center;">Pressure or Vacuum</th> <th style="text-align: center;">Voltage</th> </tr> </thead> <tbody> <tr> <td style="text-align: center;">- 66 kPa { - 500 mmHg, 19.7 inHg }</td> <td style="text-align: center;">1.3-1.6V</td> </tr> <tr> <td style="text-align: center;">0 kPa { 0 mmHg, 0 inHg }</td> <td style="text-align: center;">2.3-2.8V</td> </tr> <tr> <td style="text-align: center;">98.7 kPa { 740 mmHg, 29.1 inHg }</td> <td style="text-align: center;">4.3-4.6V</td> </tr> </tbody> </table>		Pressure or Vacuum	Voltage	- 66 kPa { - 500 mmHg, 19.7 inHg }	1.3-1.6V	0 kPa { 0 mmHg, 0 inHg }	2.3-2.8V	98.7 kPa { 740 mmHg, 29.1 inHg }	4.3-4.6V
Pressure or Vacuum	Voltage								
- 66 kPa { - 500 mmHg, 19.7 inHg }	1.3-1.6V								
0 kPa { 0 mmHg, 0 inHg }	2.3-2.8V								
98.7 kPa { 740 mmHg, 29.1 inHg }	4.3-4.6V								

17U0F-047

Circuit Diagram

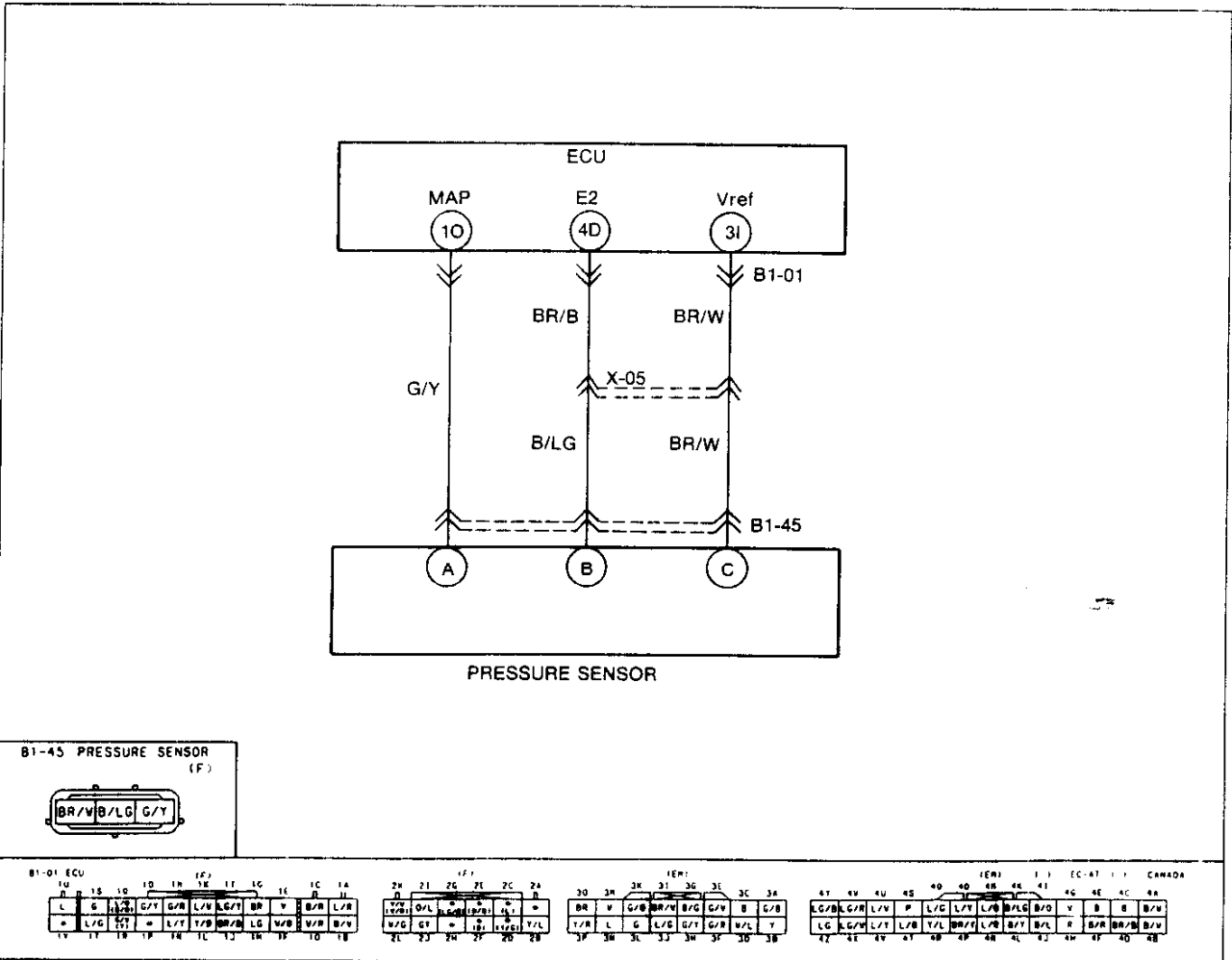

F

SELF-DIAGNOSIS FUNCTION

CODE No.	14 (ATMOSPHERIC PRESSURE SENSOR-IN ECU)	
STEP	ACTION	
1	Replace ECU	☞ page F-150

16FD12-050

CODE No.	15 (OXYGEN SENSOR-INACTIVATION)		
Note			
● If Code No.15 and 17 are both present, first perform the checking procedure for Code No.17.			
STEP	INSPECTION	ACTION	
1	Does oxygen sensor circuit have a poor connection?	Yes	Repair connector and/or wiring harness
		No	Go to next step
2	Is oxygen sensor output voltage OK?	Yes	Go to next step
		No	Replace oxygen sensor ☞ page F-113
3	Is there continuity between oxygen sensor and ECU terminal 3C (B)?	Yes	Check for short circuit in wiring ☞ page F-150 ⇨ If OK, replace ECU ⇨ If not OK, repair wire harness
		No	Repair wiring harness

17U0FX 048

Circuit Diagram

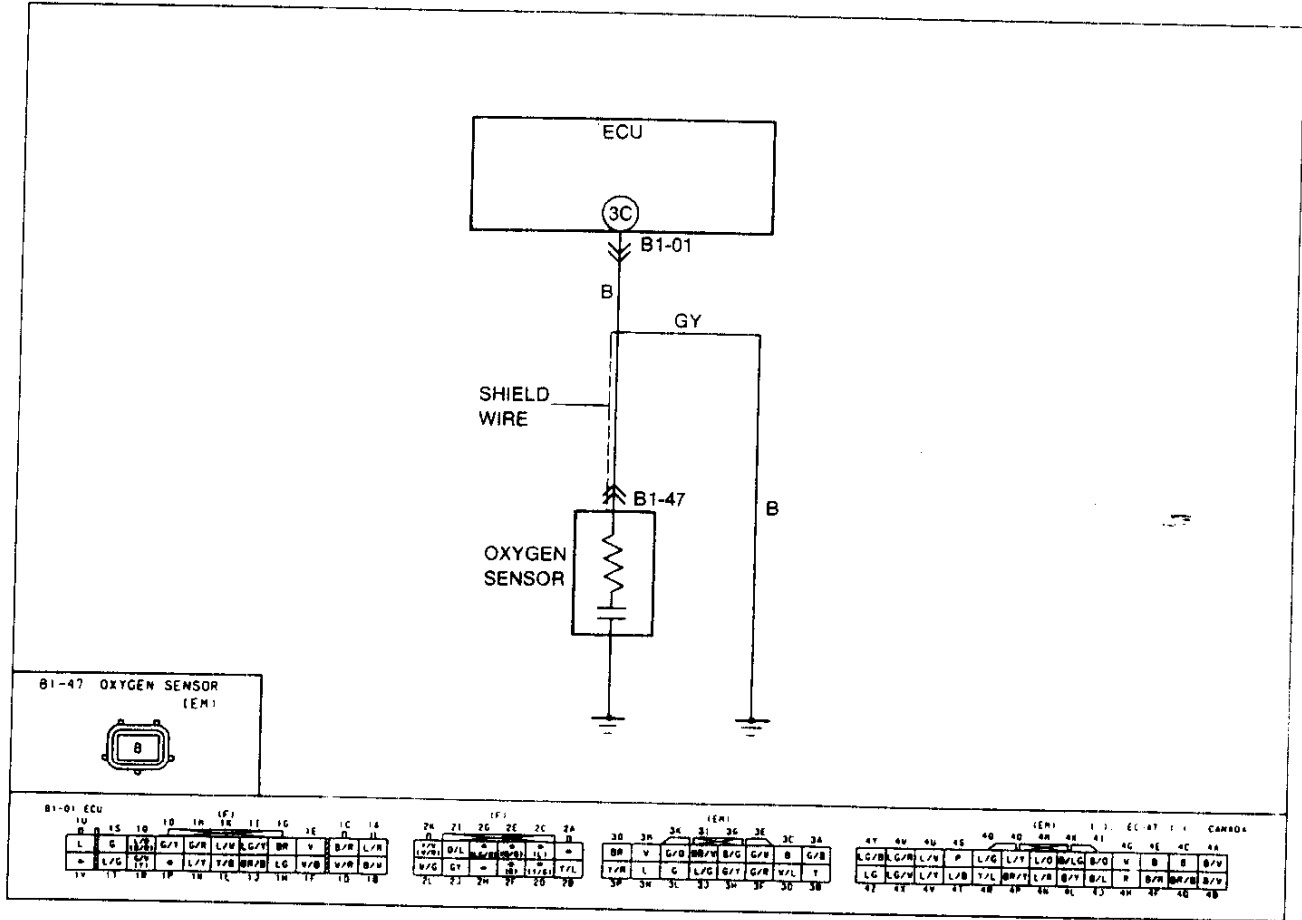

SELF-DIAGNOSIS FUNCTION

F

CODE No.	16 (EGR SWITCH) — CALIFORNIA ONLY		
STEP	INSPECTION	ACTION	ACTION
1	Does EGR switch circuit have a poor connection?	Yes	Repair connector and/or wiring harness
		No	Go to next step
2	Is connector terminal (L/G) voltage OK with EGR switch connector disconnected.	Yes	Go to next step
		No	Check for open or short circuit in wiring harness (EGR switch terminal [LG]-ECU terminal 3J)
3	Is there continuity between EGR switch terminal (BR/B) and ECU terminal 4F?	Yes	Go to next step
		No	Repair wiring harness
4	Is EGR switch OK? ☞ page F-127	Yes	Replace ECU ☞ page F-150
		No	Replace EGR valve

17U0F-049

Circuit Diagram

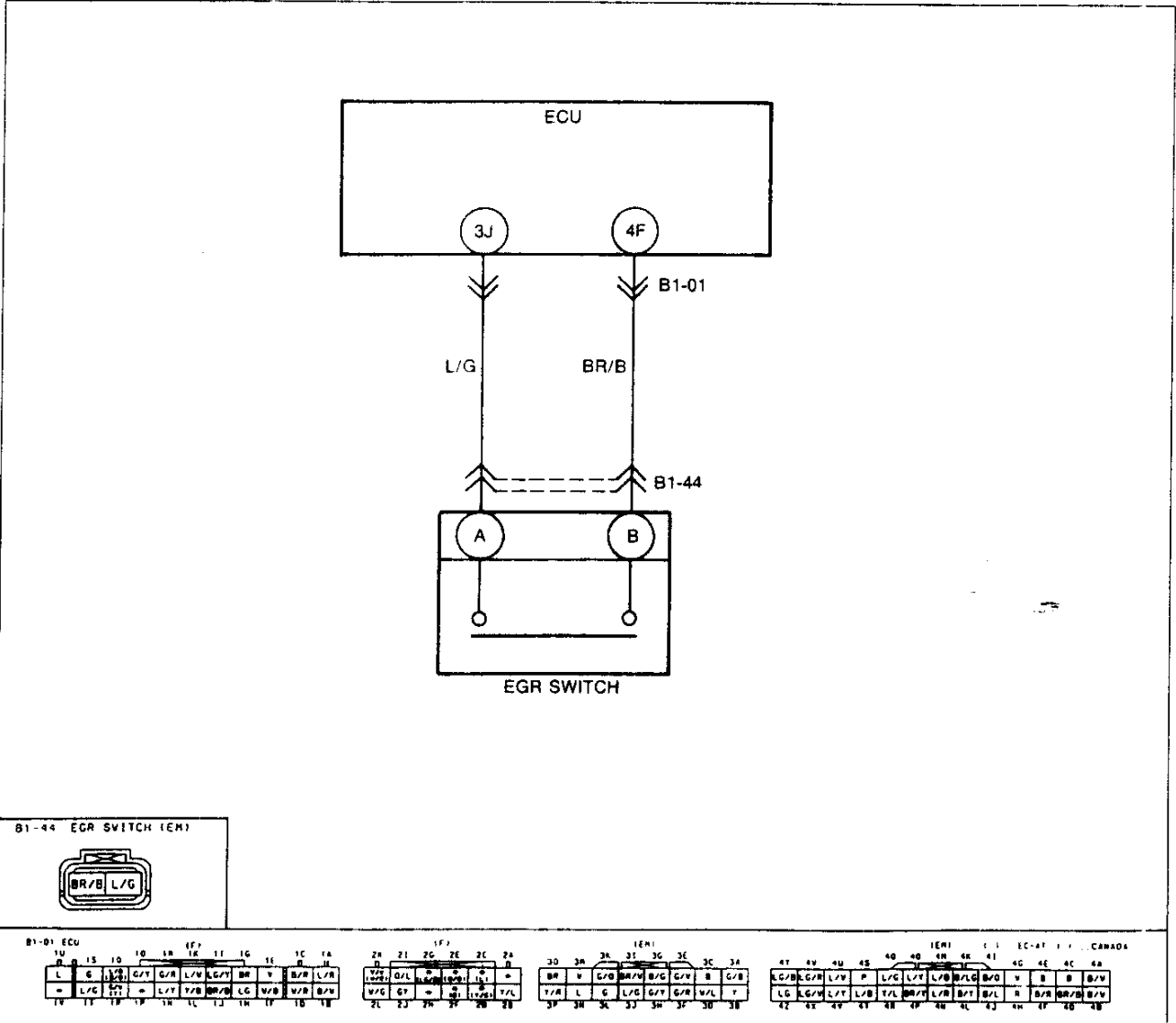

SELF-DIAGNOSIS FUNCTION

CODE No.		17 (FEEDBACK SYSTEM)	
STEP	INSPECTION		ACTION
1	Is the same Code No. present following afterrep-air procedure? ☞ page F-66	Yes	Go to next step
		No	Check oxygen sensor circuit for a poor connection ☞ If OK, perform troubleshooting Code No.15
2	Does monitor lamp of Self-Diagnosis Checker illuminate at idle after the engine has been warmed up and run at 2500-3000 rpm for 3 min?	Yes	Go to next step Note ● A/F mixture rich
		No	Go to Step 5 Note ● A/F mixture is lean or misfire is occurring
3	Is fuel line pressure correct at idle? ☞ page F-104 Fuel line pressure: 190-220 kPa {1.9-2.3 kgf/cm ² , 28-32 psi}	Yes	Go to next step
		No	High pressure ☞ page F-104 Check if fuel return hose is clogged or restricted ☞ If OK, replace pressure regulator
4	Is there fuel leakage at injector? ☞ page F-107	Yes	Replace injector ☞ page F-105
		No	Check water termosensor? ☞ page F-183 ☞ If it is OK, replace oxygen sensor ☞ If it is not OK, replace it
5	Disconnect each high tension lead at idle; does engine speed decrease equally at each rotor?	Yes	Go to next step
		No	Go to Step 8
6	Is fuel line pressure correct at idle? ☞ page F-97 Fuel line pressure: 190-220 kPa {1.9-2.3 kgf/cm ² , 28-32 psi}	Yes	Go to next step
		No	Low pressure Check fuel line pressure while pinching fuel return hose ☞ If it quickly increases, check pressure regulator ☞ page F-104 ☞ If it gradually increases, check for clogging between fuel pump and pressure regulator ☞ If hose is not clogged, check fuel pump maximum pressure ☞ page F-101
7	Is there air leakage in intake air system components?	Yes	Replace oxygen sensor
		No	Repair ☞ page F-76
8	Is there a misfire of a dead rotor from Step 5 inspection?	Yes	Repair or replace ignition system component(s)
		No	Go to next step

V_B: Battery voltage

STEP	INSPECTION		ACTION
9	Is there an injector operating sound at idle of dead rotor from Step 5 inspection?	Yes	Go to next step
		No	Check for approx. V _B at injector terminal wire ⇨ If there is, replace injector ⇨ page F-105 ⇨ If there is not, check for a short or open circuit in wire harness
10	Replace injector at dead rotor from Step 5 inspection	Yes	Try known good ECU
	Is the same Code No. present following afterrepair procedure? ⇨ page F-105	No	System OK

17U0F-050

Circuit Diagram

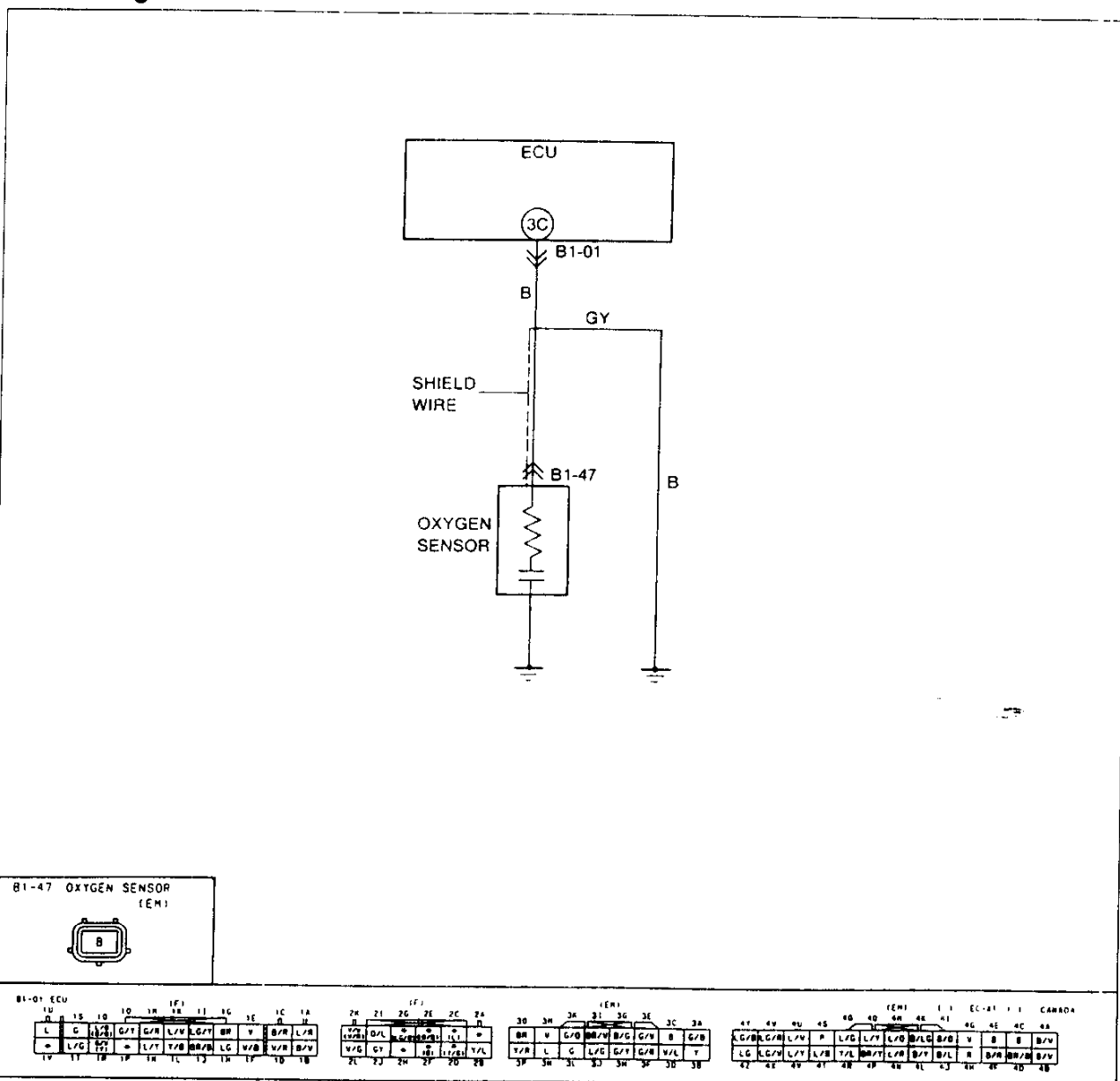

F

SELF-DIAGNOSIS FUNCTION

CODE No.	18 (THROTTLE SENSOR [NARROW RANGE])		
STEP	INSPECTION	ACTION	
1	Does throttle sensor circuit have a poor connection?	Yes	Repair connector and/or wiring harness
		No	Go to next step
2	Is throttle sensor terminal (BR/W) voltage OK with throttle sensor disconnected?	Yes	Go to next step
		No	Check for open or short circuit in wiring harness (Throttle sensor terminal [BR/W]-ECU terminal 3I) ➡ If OK, replace ECU ➡ If not OK, repair wiring harness
3	Is there continuity between throttle sensor and ECU?	Yes	Check for short circuit in wiring harness (Throttle sensor terminal (G/R)-ECU terminal 3F) ➡ If OK, go to next step ➡ If not OK, repair wiring harness
		No	Repair wiring harness
4	Is there continuity between terminals (BR/W) and (G/R) with throttle valve closed to fully opened OK?	Yes	Replace ECU ➡ page F-150
		No	Replace throttle sensor ➡ page F-182

17UJFX 051

Circuit Diagram

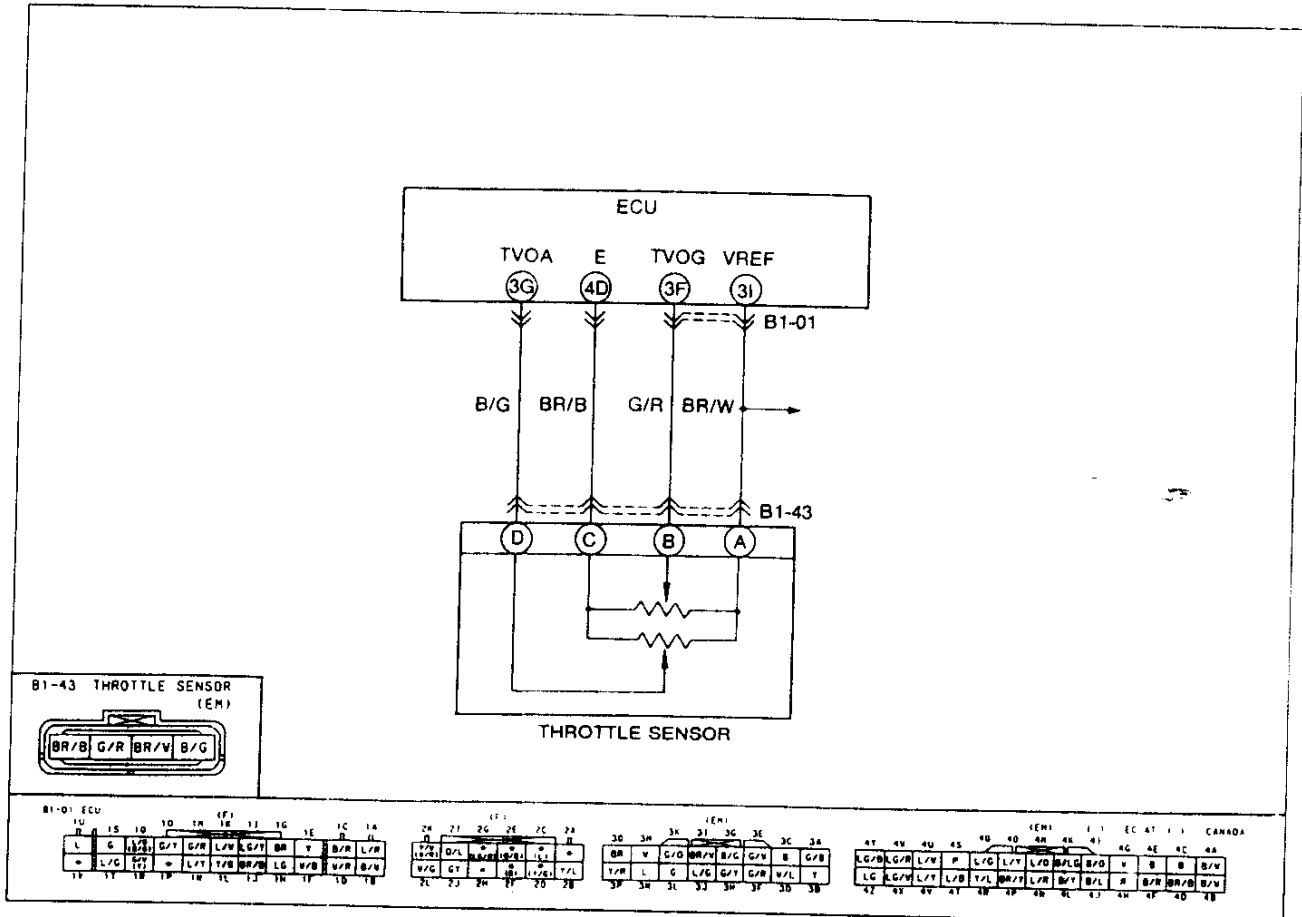

SELF-DIAGNOSIS FUNCTION

F

CODE No.	20 (METERING OIL PUMP POSITION SENSOR)							
STEP	INSPECTION	ACTION						
1	Are there any poor connections at metering oil pump and ECU connectors?	Yes	Repair or replace connector					
		No	Go to next step					
2	Is ECU terminal 3A (G/B) voltage OK?	Yes	Go to step 4					
		No	Go to next step					
<table border="1" style="width: 100%; border-collapse: collapse; margin: 5px 0;"> <thead> <tr> <th style="width: 50%;">Condition</th> <th style="width: 50%;">Voltage</th> </tr> </thead> <tbody> <tr> <td style="text-align: center;">Idle</td> <td style="text-align: center;">1.1V</td> </tr> <tr> <td style="text-align: center;">Acceleration</td> <td style="text-align: center;">1.1V-4.2V</td> </tr> </tbody> </table>			Condition	Voltage	Idle	1.1V	Acceleration	1.1V-4.2V
Condition	Voltage							
Idle	1.1V							
Acceleration	1.1V-4.2V							
3	Is resistance of MOF position sensor OK? Resistance: J-H 0.4-2 kΩ J-I 1.0-2 kΩ H-I 0.4-12 kΩ	Yes	Repair wiring harness (Mop position sensor-ECU terminal 3A)					
		No	Replace MOP					
4	Disconnect negative battery cable for at least 20 seconds Connect battery cable and recheck for service code Is service code displayed?	Yes	Replace ECU					
		No	Intermittent poor connection check for cause.					

Circuit Diagram

17U0F>-052

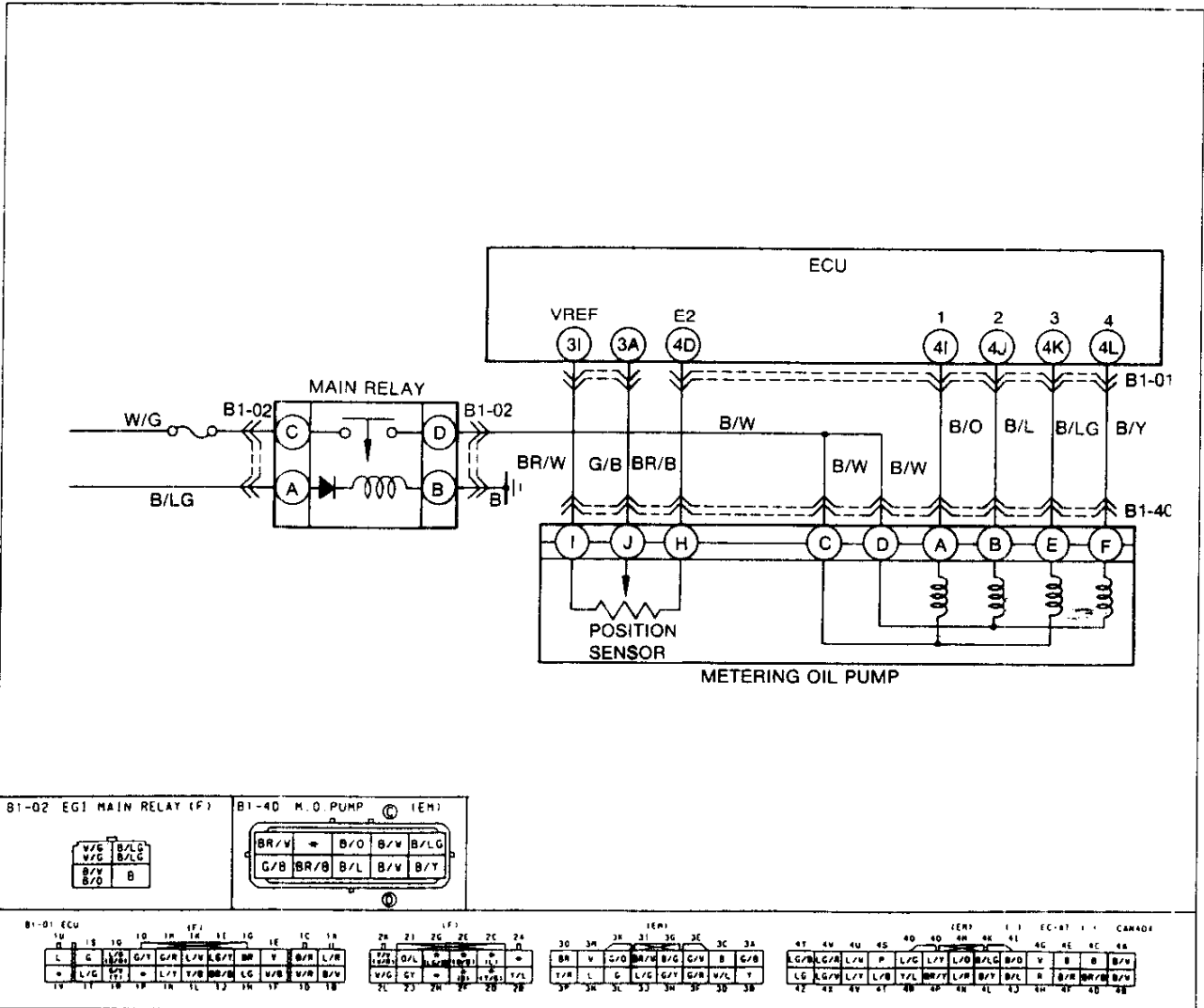

F

SELF-DIAGNOSIS FUNCTION

CODE No.	23 (FUEL THERMOSENSOR)		
STEP	INSPECTION	ACTION	
1	Does the fuel thermosensor circuit have a poor connection?	Yes	Repair connector and/or harness
		No	Go to next step
2	Is fuel thermosensor terminal (BR/B) voltage OK with fuel thermosensor connector disconnected?	Yes	Go to next step
		No	Check for short or open circuit in wiring harness (fuel thermosensor terminal [BR/B]-ECU terminal 1U) ➡ If OK, replace ECU ➡ If not OK, repair wiring harness
3	Is there continuity between fuel thermosensor terminal (BR/Y) and a ground?	Yes	Go to next step
		No	Repair wiring harness
4	Is resistance of fuel thermosensor OK?	Yes	Replace ECU ➡ page F-15)
		No	Replace fuel thermosensor ➡ page F-18)

Condition	Voltage
Ignition switch ON	Aprox. 5.0 V

Fuel temp	Resistance {kΩ}
-20°C {-4°F}	14.6-17.8
20°C {68°F}	2.2-2.7
80°C {176°F}	0.29-0.35

Circuit Diagram

17U0FX 053

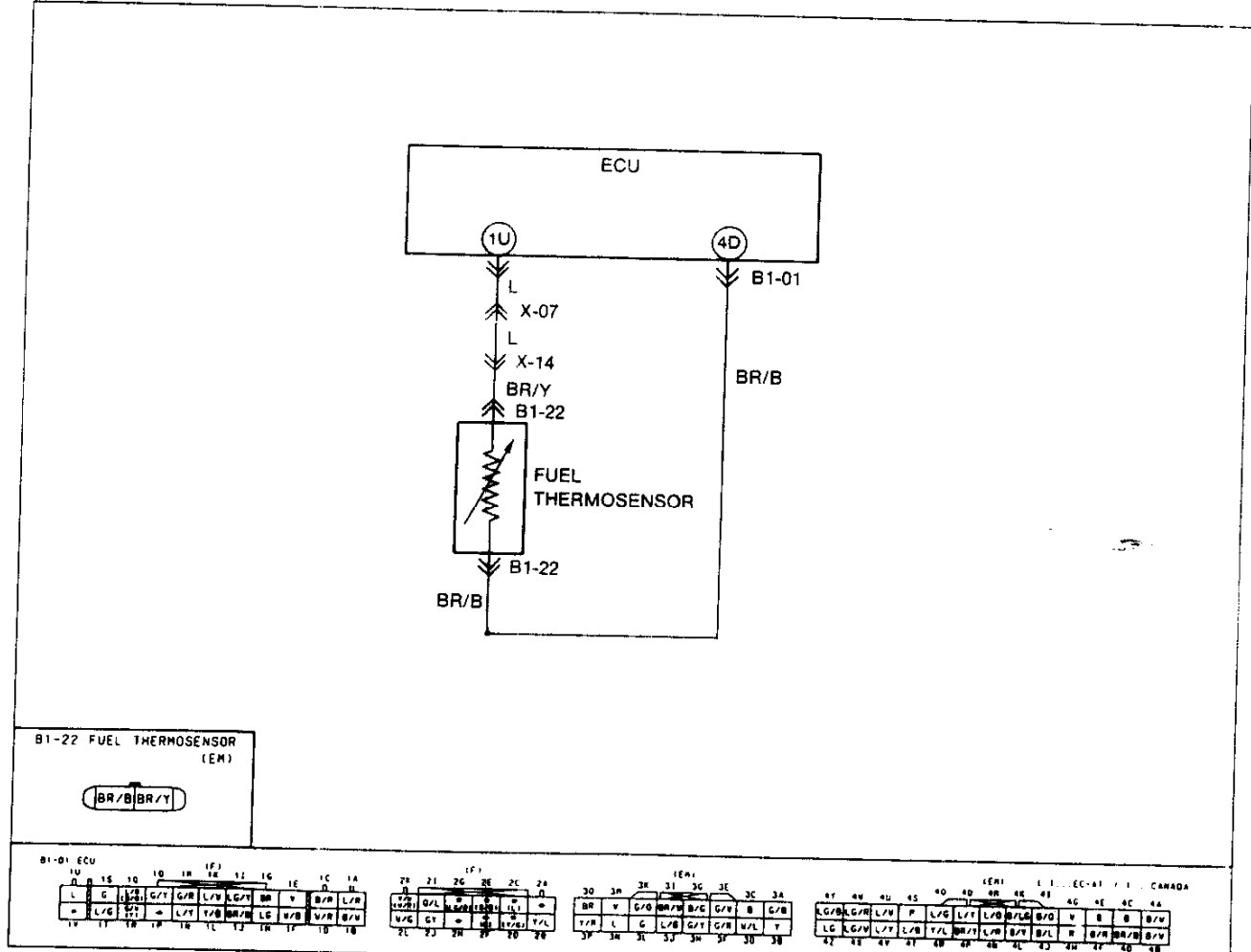

SELF-DIAGNOSIS FUNCTION

F

CODE No.	25 (SOLENOID VALVE-PRESSURE REGULATOR CONTROL [PRC])						
STEP	INSPECTION	ACTION					
1	Does solenoid valve circuit have a poor connection?	Yes	Repair connector and/or wiring harness				
		No	Go to next step				
2	Is connector terminal (B/W) voltage OK with solenoid valve connector disconnected?	Yes	Go to next step				
		No	Check for open or short circuit in wiring harness (Solenoid valve terminal [B/W]-Main relay terminal [B/W])				
<table border="1" style="width: 100%; border-collapse: collapse;"> <thead> <tr> <th style="width: 50%;">Condition</th> <th style="width: 50%;">Voltage</th> </tr> </thead> <tbody> <tr> <td style="text-align: center;">Ignition switch ON</td> <td style="text-align: center;">Battery voltage</td> </tr> </tbody> </table>		Condition	Voltage	Ignition switch ON	Battery voltage		
Condition	Voltage						
Ignition switch ON	Battery voltage						
3	Is there continuity between solenoid valve terminal (L/O) and ECU terminal 4M?	Yes	Check for short circuit in wiring harness (Solenoid valve terminal [L/O]-ECU terminal 4M) ⇨ If OK, go to next step ⇨ If not OK, repair wiring harness				
		No	Repair wiring harness				
4	Is solenoid valve OK? ⇨ page F-190	Yes	Replace ECU ⇨ page F-150				
		No	Replace solenoid valve				

17U0FX 054

Circuit Diagram

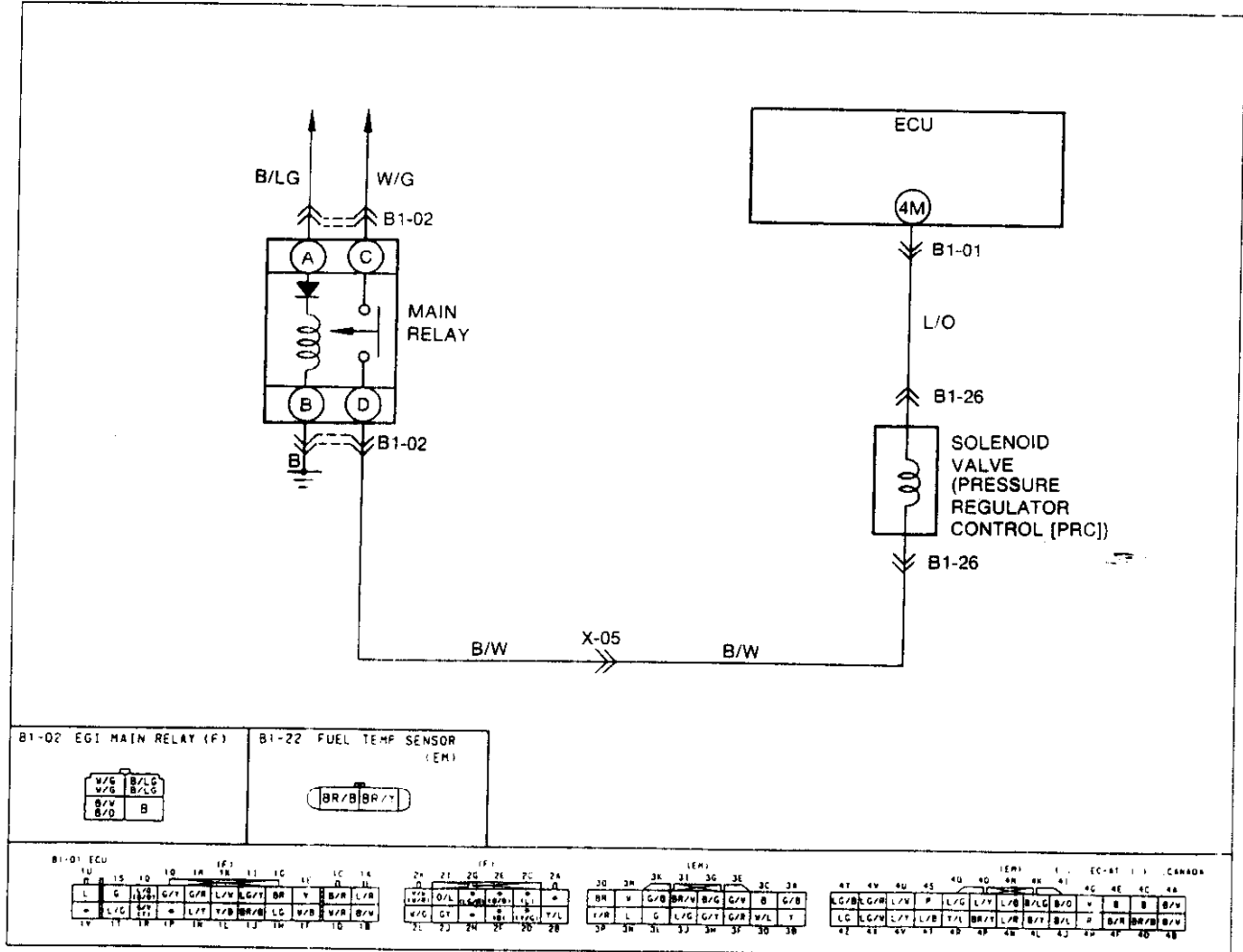

F

SELF-DIAGNOSIS FUNCTION

CODE No.	26 (METERING OIL PUMP STEPPING MOTOR)		
STEP	INSPECTION	ACTION	
1	Are there any poor connections at metering oil pump and ECU connector?	Yes	Repair or replace connector
		No	Go to next step
2	Is resistance of MOP stepping motor OK? Resistance:	Yes	Go to next step
		No	Replace MOP
3	Is continuity between MOP stepping motor and ECU terminals OK?	Yes	Repair wiring harness (MOP-Main relay)
		No	Repair wiring harness (MOP-ECU terminals)
4	Disconnect negative battery cable for at least 20 seconds Connect battery cable and recheck for service code Is service code displayed?	Yes	Replace ECU
		No	Intermittent poor connection check for cause

17U0FX 055

Circuit Diagram

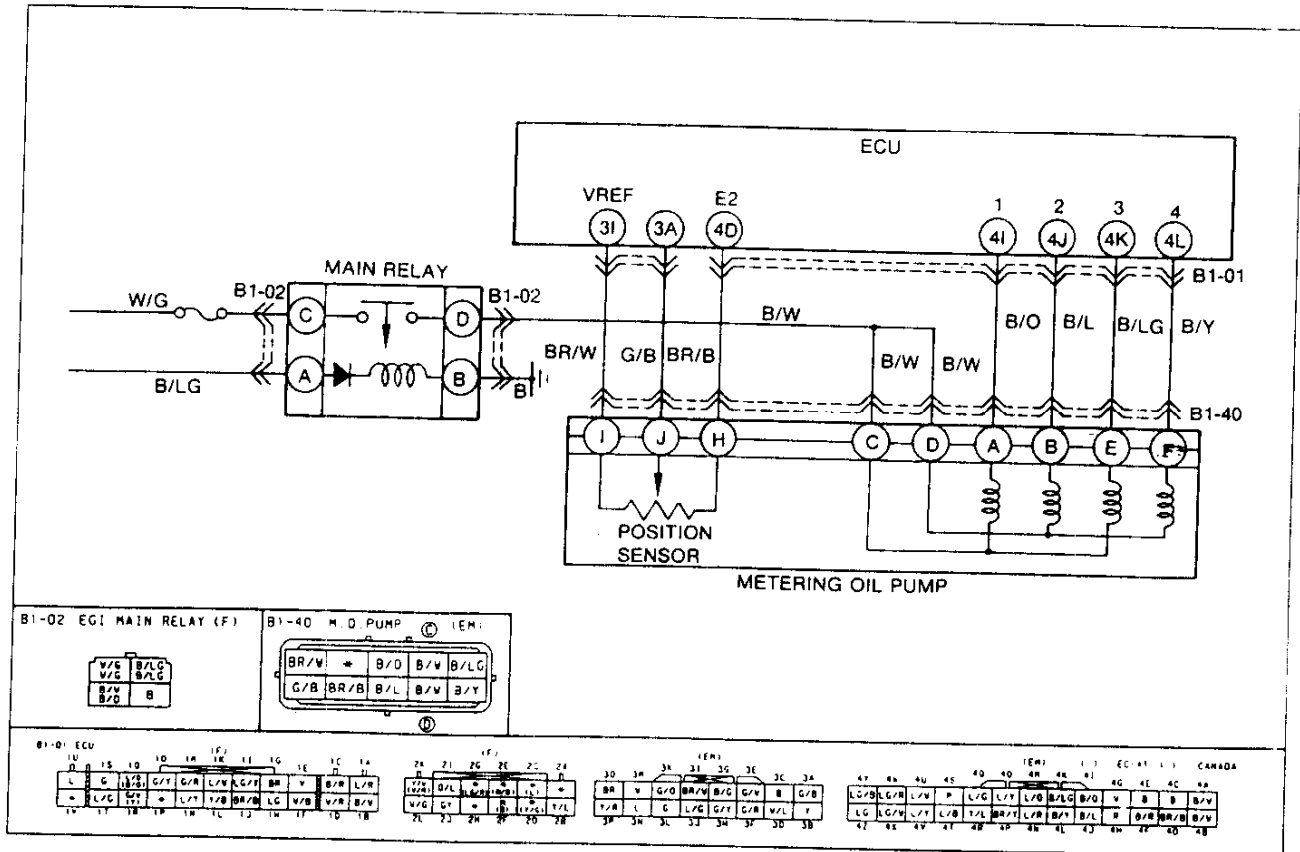

SELF-DIAGNOSIS FUNCTION

F

CODE No.	27 (METERING OIL PUMP)																	
STEP	INSPECTION		ACTION															
1	Are there any poor connections at metering oil pump and ECU connector?	Yes	Repair or replace connector															
		No	Go to next step															
2	Is ECU terminal 3A voltage OK? <table border="1" style="margin-left: auto; margin-right: auto; border-collapse: collapse;"> <tr> <td style="text-align: center;">Condition</td> <td style="text-align: center;">Voltage</td> </tr> <tr> <td style="text-align: center;">Idle</td> <td style="text-align: center;">1.1V</td> </tr> <tr> <td style="text-align: center;">Acceleration</td> <td style="text-align: center;">1.0V-4.2V</td> </tr> </table>	Condition	Voltage	Idle	1.1V	Acceleration	1.0V-4.2V	Yes	Go to step 4									
		Condition	Voltage															
Idle	1.1V																	
Acceleration	1.0V-4.2V																	
		No	Go to next step															
3	Is resistance of MOP position sensor OK? Resistance: J-H 0.4-12 kΩ J-I 10-2 kΩ H-I 0.4-12 kΩ	Yes	Go to next step															
		No	Replace MOP															
4	Is ECU terminals voltage OK? Specification: (Idle) <table border="1" style="margin-left: auto; margin-right: auto; border-collapse: collapse;"> <tr> <td style="text-align: center;">Stepping Motor</td> <td style="text-align: center;">ECU terminal</td> <td style="text-align: center;">Output voltage</td> </tr> <tr> <td style="text-align: center;">SM1 A</td> <td style="text-align: center;">4I (B/O)</td> <td style="text-align: center;">One terminal: V_B</td> </tr> <tr> <td style="text-align: center;">SM2 B</td> <td style="text-align: center;">4J (B/L)</td> <td style="text-align: center;">Three terminals: 5-9 V</td> </tr> <tr> <td style="text-align: center;">SM3 E</td> <td style="text-align: center;">4K (B/LG)</td> <td></td> </tr> <tr> <td style="text-align: center;">SM4 F</td> <td style="text-align: center;">4L (B/Y)</td> <td></td> </tr> </table>	Stepping Motor	ECU terminal	Output voltage	SM1 A	4I (B/O)	One terminal: V _B	SM2 B	4J (B/L)	Three terminals: 5-9 V	SM3 E	4K (B/LG)		SM4 F	4L (B/Y)		Yes	Go to step 7
		Stepping Motor	ECU terminal	Output voltage														
SM1 A	4I (B/O)	One terminal: V _B																
SM2 B	4J (B/L)	Three terminals: 5-9 V																
SM3 E	4K (B/LG)																	
SM4 F	4L (B/Y)																	
		No	Go to next step															
5	Is resistance of MOP stepping motor OK? Resistance: <table border="1" style="margin-left: auto; margin-right: auto; border-collapse: collapse;"> <tr> <td style="text-align: center;">terminal</td> <td style="text-align: center;">kΩ</td> </tr> <tr> <td style="text-align: center;">C - SM1 A</td> <td rowspan="4" style="text-align: center; vertical-align: middle;">16-31</td> </tr> <tr> <td style="text-align: center;">C - SM3 E</td> </tr> <tr> <td style="text-align: center;">D - SM2 B</td> </tr> <tr> <td style="text-align: center;">D - SM4 F</td> </tr> </table>	terminal	kΩ	C - SM1 A	16-31	C - SM3 E	D - SM2 B	D - SM4 F	Yes	Go to next step								
		terminal	kΩ															
C - SM1 A	16-31																	
C - SM3 E																		
D - SM2 B																		
D - SM4 F																		
		No	Replace MOP															
6	Is continuity between MOP stepping motor and ECU terminals OK? <table border="1" style="margin-left: auto; margin-right: auto; border-collapse: collapse;"> <tr> <td style="text-align: center;">MOP terminal</td> <td style="text-align: center;">ECU terminal</td> </tr> <tr> <td style="text-align: center;">SM1 A</td> <td style="text-align: center;">4I (B/O)</td> </tr> <tr> <td style="text-align: center;">SM2 B</td> <td style="text-align: center;">4J (B/L)</td> </tr> <tr> <td style="text-align: center;">SM3 E</td> <td style="text-align: center;">4K (B/LG)</td> </tr> <tr> <td style="text-align: center;">SM4 F</td> <td style="text-align: center;">4L (B/Y)</td> </tr> </table>	MOP terminal	ECU terminal	SM1 A	4I (B/O)	SM2 B	4J (B/L)	SM3 E	4K (B/LG)	SM4 F	4L (B/Y)	Yes	Repair wiring harness (MOP-Main relay)					
		MOP terminal	ECU terminal															
SM1 A	4I (B/O)																	
SM2 B	4J (B/L)																	
SM3 E	4K (B/LG)																	
SM4 F	4L (B/Y)																	
		No	Repair wiring harness (MOP-ECU terminals)															
7	Disconnect negative battery cable for at least 20 seconds Connect battery cable and recheck for service code Is service code displayed?	Yes	Replace ECU															
		No	Intermittent poor connection check for cause															

17U0FX-156

Circuit Diagram
(Refer to page F-42)

F

SELF-DIAGNOSIS FUNCTION

CODE No.	28 (SOLENOID VALVE-EGR)					
STEP	INSPECTION	ACTION				
1	Does solenoid valve circuit have a poor connection?	Yes	Repair connector and/or wiring harness			
		No	Go to next step			
2	Is connector terminal (B/W) voltage OK with solenoid valve connector disconnected?	Yes	Go to next step			
		No	Check for open or short circuit in wiring harness (Solenoid valve terminal [B/W]-Main relay terminal [B/W])			
<table border="1"> <thead> <tr> <th>Condition</th> <th>Voltage</th> </tr> </thead> <tbody> <tr> <td>Ignition switch ON</td> <td>Battery voltage</td> </tr> </tbody> </table>		Condition	Voltage	Ignition switch ON	Battery voltage	
Condition	Voltage					
Ignition switch ON	Battery voltage					
3	Is there continuity between solenoid valve terminal (L/Y) and ECU terminal 40?	Yes	Check for short circuit in wiring harness (Solenoid valve terminal [L/Y]-ECU terminal 40) ⇨ If OK, go to next step ⇨ If not OK, repair wiring harness			
		No	Repair wiring harness			
4	Is solenoid valve OK? ⇨ page F-190	Yes	Replace ECU ⇨ page F-150			
		No	Replace solenoid valve			

Circuit Diagram

17U0FX 057

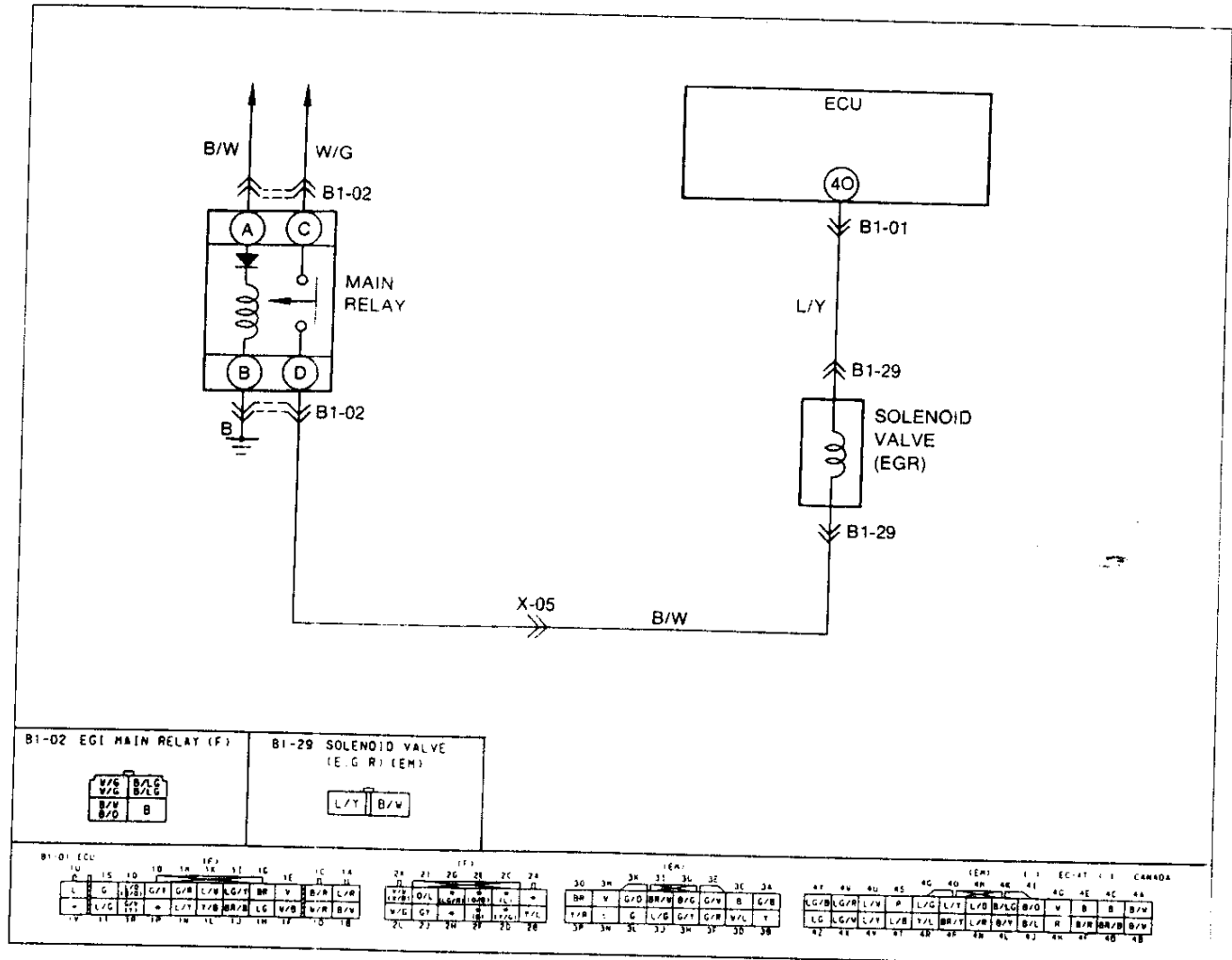

SELF-DIAGNOSIS FUNCTION

F

CODE No.	38 (SOLENOID VALVE-SPLIT AIR BYPASS)						
STEP	INSPECTION	Yes	ACTION				
1	Does solenoid valve circuit have a poor connection?	Yes	Repair connector and/or wiring harness				
		No	Go to next step				
2	Is connector terminal (B/W) voltage OK with solenoid valve connector disconnected?	Yes	Go to next step				
		No	Check for open or short circuit in wiring harness (Solenoid valve terminal [B/W]-Main relay terminal [B/W])				
<table border="1" style="margin-left: auto; margin-right: auto;"> <thead> <tr> <th style="text-align: center;">Condition</th> <th style="text-align: center;">Voltage</th> </tr> </thead> <tbody> <tr> <td style="text-align: center;">Ignition switch ON</td> <td style="text-align: center;">Battery voltage</td> </tr> </tbody> </table>		Condition	Voltage	Ignition switch ON	Battery voltage		
Condition	Voltage						
Ignition switch ON	Battery voltage						
3	Is there continuity between solenoid valve terminal (B/R) and ECU terminal 4F?	Yes	Check for short circuit in wiring harness (Solenoid valve terminal [B/R]-ECU terminal 4F) ➡ If OK, go to next step ➡ If not OK, repair wiring harness				
		No	Repair wiring harness				
4	Is solenoid valve OK? ➡ page F-120	Yes	Replace ECU ➡ page F-151				
		No	Replace solenoid valve				

17U0F> 058

Circuit Diagram

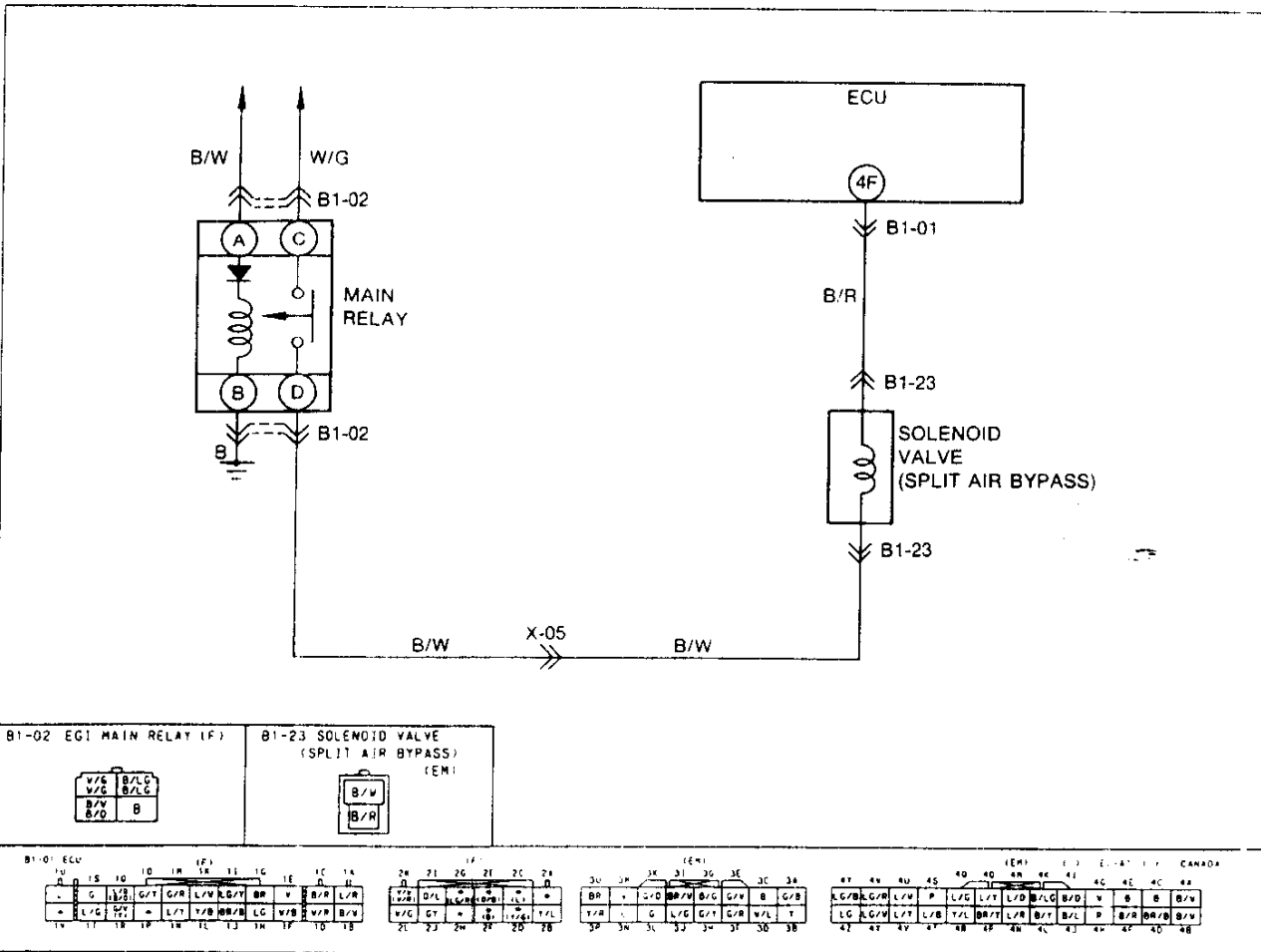

F

SELF-DIAGNOSIS FUNCTION

CODE No.	31 (SOLENOID VALVE-RELIEF 1)		
STEP	INSPECTION		ACTION
1	Does solenoid valve circuit have a poor connection?	Yes	Repair connector and/or wiring harness
		No	Go to next step
2	Is connector terminal (B/W) voltage OK with solenoid valve connector disconnected?	Yes	Go to next step
		No	Check for open or short circuit in wiring harness (Solenoid valve terminal [B/W]-Main relay terminal [B/W])
3	Is there continuity between solenoid valve terminal (Y/R) and ECU terminal 3P?	Yes	Check for short circuit in wiring harness (Solenoid valve terminal [Y/R]-ECU terminal 3P) ➡ If OK, go to next step ➡ If not OK, repair wiring harness
		No	Repair wiring harness
4	Is solenoid valve OK? ➡ page F-123	Yes	Replace ECU ➡ page F-150
		No	Replace solenoid valve

Circuit Diagram

17U0FX 059

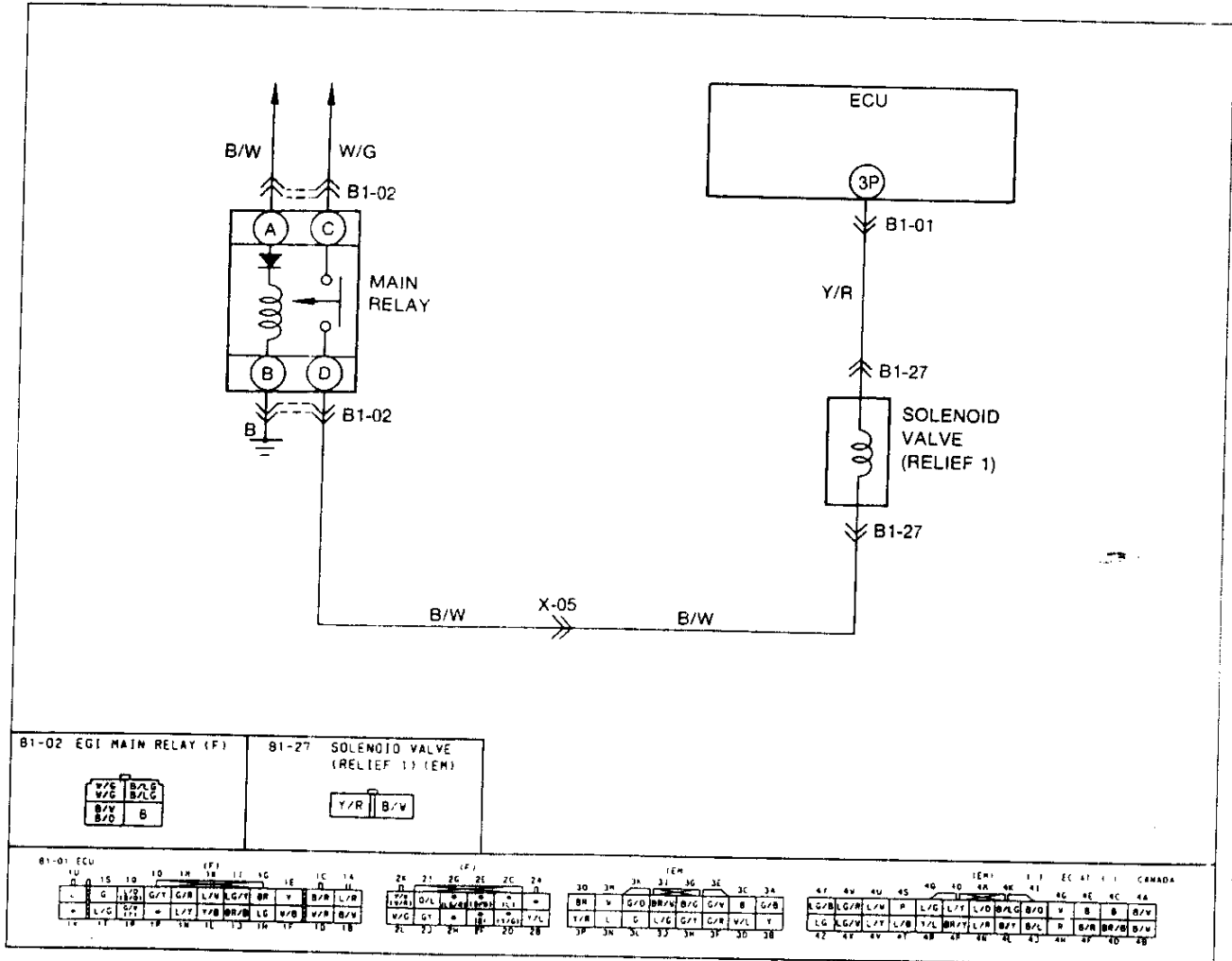

SELF-DIAGNOSIS FUNCTION

F

CODE No.	32 (SOLENOID VALVE-SWITCHING)		
STEP	INSPECTION		ACTION
1	Does solenoid valve circuit have a poor connection?	Yes	Repair connector and/or wiring harness
		No	Go to next step
2	Is connector terminal (B/W) voltage OK with solenoid valve connector disconnected?	Yes	Go to next step
		No	Check for open or short circuit in wiring harness (Solenoid valve terminal [B/W]-Main relay terminal [B/W])
3	Is there continuity between solenoid valve terminal (L/R) and ECU terminal 4N?	Yes	Check for short circuit in wiring harness (Solenoid valve terminal [L/R]-ECU terminal 4N) ⇨ If OK, go to next step ⇨ If not OK, repair wiring harness
		No	Repair wiring harness
4	Is solenoid valve OK? ☞ page F-190	Yes	Replace ECU ☞ page F-153
		No	Replace solenoid valve

Circuit Diagram

17U0F>-060

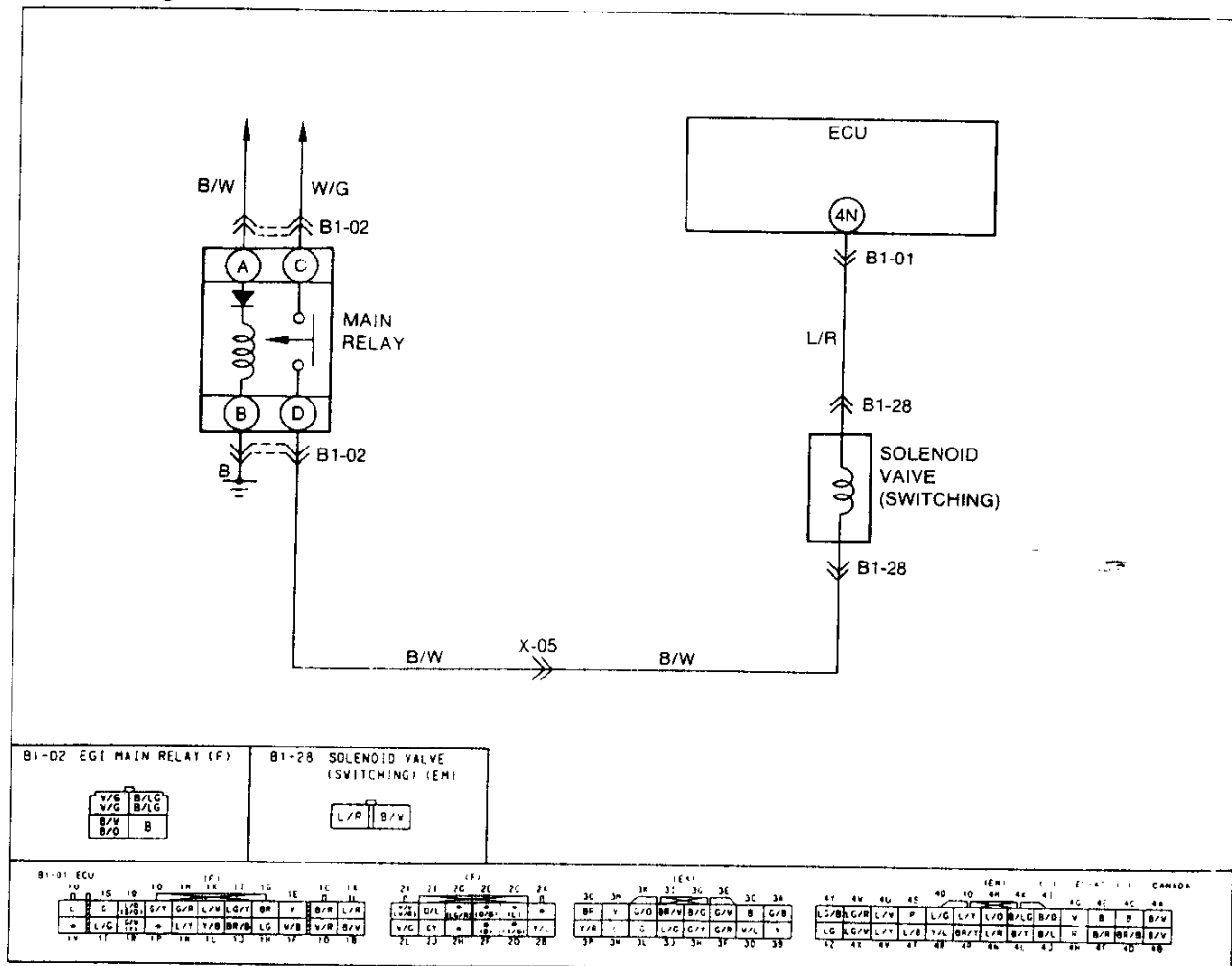

F

SELF-DIAGNOSIS FUNCTION

CODE No.	33 (SOLENOID VALVE-PORT AIR BYPASS)		
STEP	INSPECTION		ACTION
1	Does solenoid valve circuit have a poor connection?	Yes	Repair connector and/or wiring harness
		No	Go to next step
2	Is connector terminal (B/W) voltage OK with solenoid valve connector disconnected?	Yes	Go to next step
		No	Check for open or short circuit in wiring harness (Solenoid valve terminal [B/W]-Main relay terminal [B/W])
3	Is there continuity between solenoid valve terminal (L) and ECU terminal 3N?	Yes	Check for short circuit in wiring harness (Solenoid valve terminal [L]-ECU terminal 3N) ⇨ If OK, go to next step ⇨ If not OK, repair wiring harness
		No	Repair wiring harness
4	Is solenoid valve OK? ⇨ page F-119	Yes	Replace ECU ⇨ page F-150
		No	Replace solenoid valve

Circuit Diagram

17U0FX 061

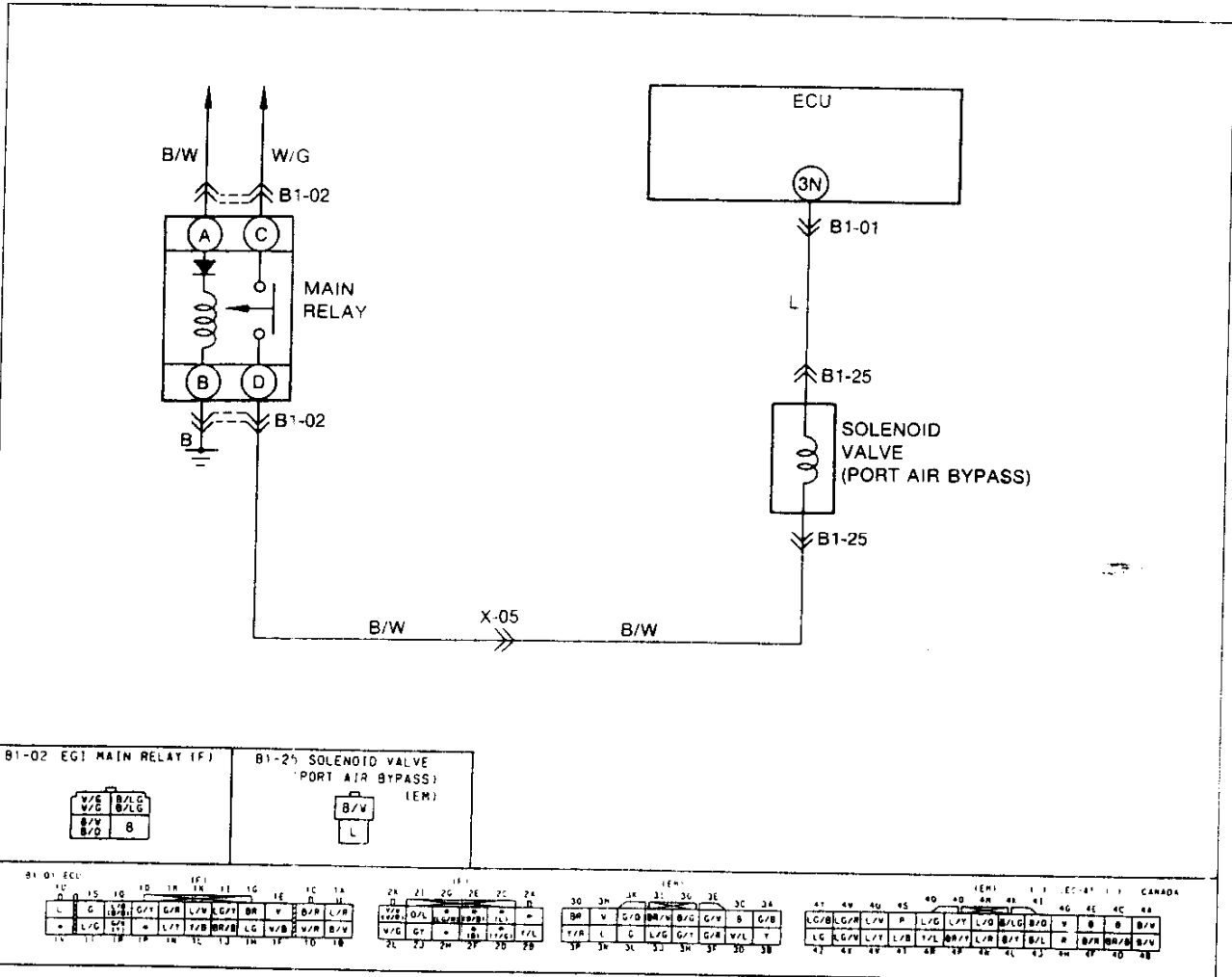

CODE No.	34 (SOLENOID VALVE-IDLE SPEED CONTROL)		ACTION
STEP	INSPECTION		
1	Does solenoid valve circuit have a poor connection?	Yes	Repair connector and/or wiring harness
		No	Go to next step
2	Is connector terminal (B/W) voltage OK with solenoid valve connector disconnected?	Yes	Go to next step
		No	Check for open or short circuit in wiring harness (Solenoid valve terminal [B/W]-Main relay terminal [B/W])
3	Is there continuity between solenoid valve terminal (L/G) and ECU terminal 4Q?	Yes	Check for short circuit in wiring harness (Solenoid valve terminal [L/G]-ECU terminal 4Q) ➔ If OK, go to next step ➔ If not OK, repair wiring harness
		No	Repair wiring harness
4	Is solenoid valve OK? ☞ page F-83	Yes	Replace ECU ☞ page F-150
		No	Replace solenoid valve

Circuit Diagram

17U0F-062

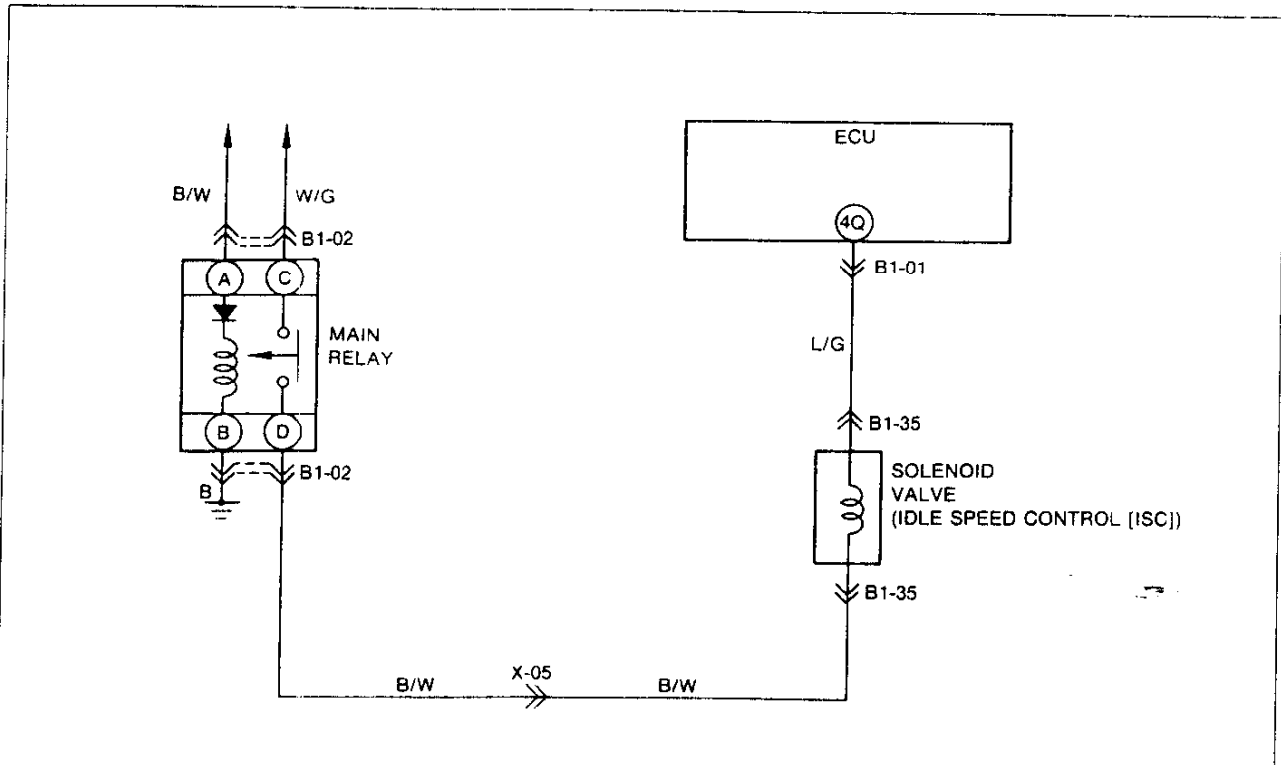

B1-02 EGI MAIN RELAY (F) 	B1-35 SOLENOID VALVE (ISC) (EM)
-------------------------------------	--

B1-01 ECU										IF1										EM1										EM2										EC-AT T T CANADA																																																		
10	11	12	13	14	15	16	17	18	19	20	21	22	23	24	25	26	27	28	29	30	31	32	33	34	35	36	37	38	39	40	41	42	43	44	45	46	47	48	49	50	51	52	53	54	55	56	57	58	59																																									
L	G	L/V	G/T	G/R	L/V	G/T	B/R	V	B/R	L/R	V/W	ST	+	+	V/G	1/L	+			V/R	L	G	L/G	G/T	G/R	W/L	Y			LC	R/G	L/T	L/B	T/L	B/R	L/R	B/T	B/L	R	B/R	B/R	B/V										42	43	44	45	46	47	48	49	50	51	52	53	54	55	56	57	58	59	60	61	62	63	64	65	66	67	68	69	70	71	72	73	74	75	76	77	78	79	80

F

SELF-DIAGNOSIS FUNCTION

CODE No.		37 (METERING OIL PUMP)	
STEP	INSPECTION	ACTION	
1	Is battery voltage OK?	Yes	Go to next step
	Specification: 12-14V (at Idle)	No	Repair charging system and/or Battery
2	Disconnect negative battery cable for at least 20 seconds	Yes	Replace ECU
	Connect battery cable and recheck for service code Is service code displayed?	No	Intermittent poor connection Check for cause

17U0F-063

Circuit Diagram

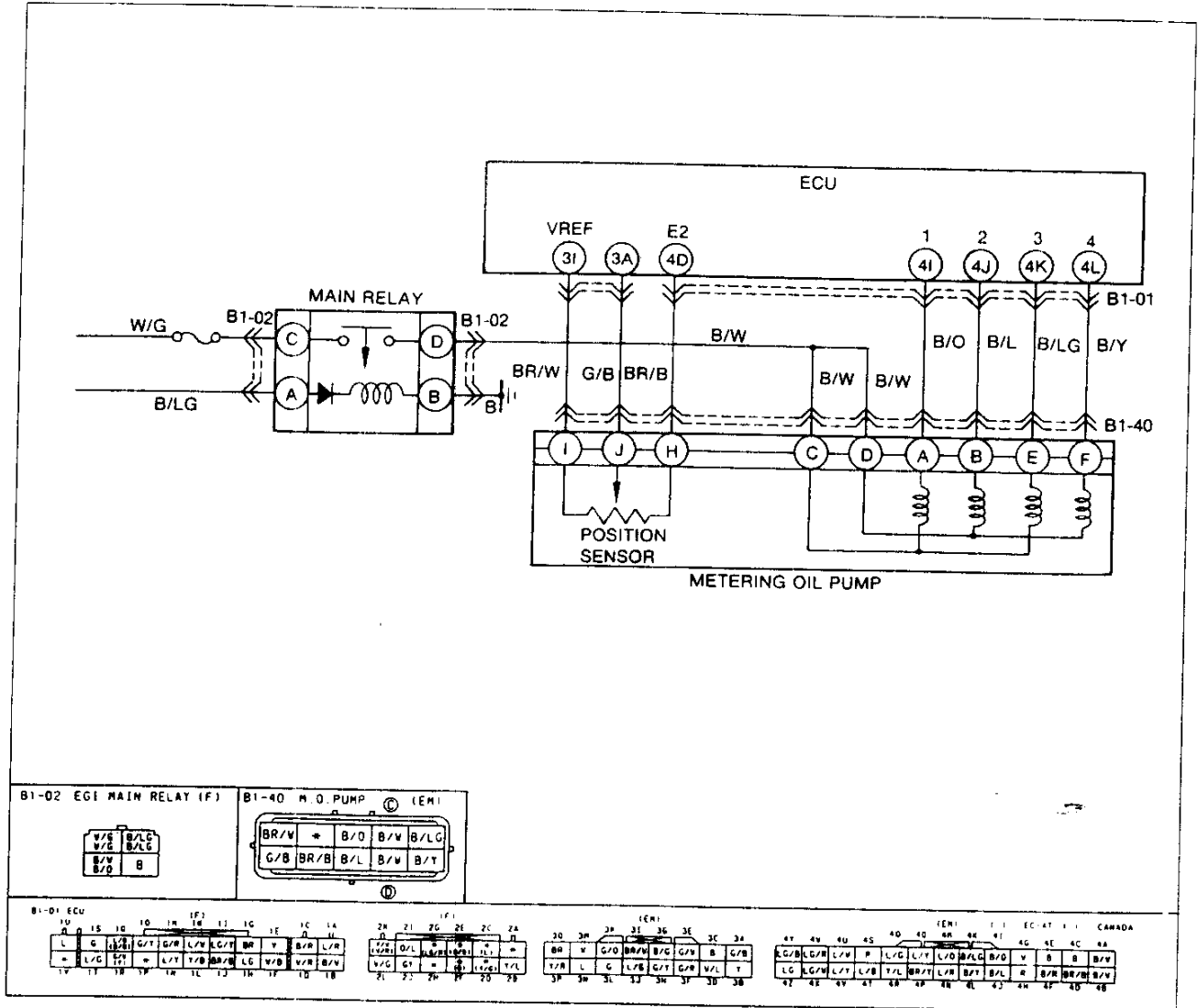

F

SELF-DIAGNOSIS FUNCTION

CODE No.	39 (SOLENOID VALVE-RELIEF 2)						
STEP	INSPECTION		ACTION				
1	Does solenoid valve circuit have a poor connection?	Yes	Repair connector and/or wiring harness				
		No	Go to next step				
2	Is connector terminal (B/W) voltage OK with solenoid valve connector disconnected?	Yes	Go to next step				
		No	Check for open or short circuit in wiring harness (Solenoid valve terminal [B/W]-Main relay terminal [B/W])				
<table border="1"> <thead> <tr> <th>Condition</th> <th>Voltage</th> </tr> </thead> <tbody> <tr> <td>Ignition switch ON</td> <td>Battery voltage</td> </tr> </tbody> </table>		Condition	Voltage	Ignition switch ON	Battery voltage		
Condition	Voltage						
Ignition switch ON	Battery voltage						
3	Is there continuity between solenoid valve terminal (G/O) and ECU terminal 3K?	Yes	Check for short circuit in wiring harness (Solenoid valve terminal [G/O]-ECU terminal 3K) ➡ If OK, go to next step ➡ If not OK, repair wiring harness				
		No	Repair wiring harness				
4	Is solenoid valve OK? ➡ page F-123	Yes	Replace ECU ➡ page F-150				
		No	Replace solenoid valve				

Circuit Diagram

17UJFX 065

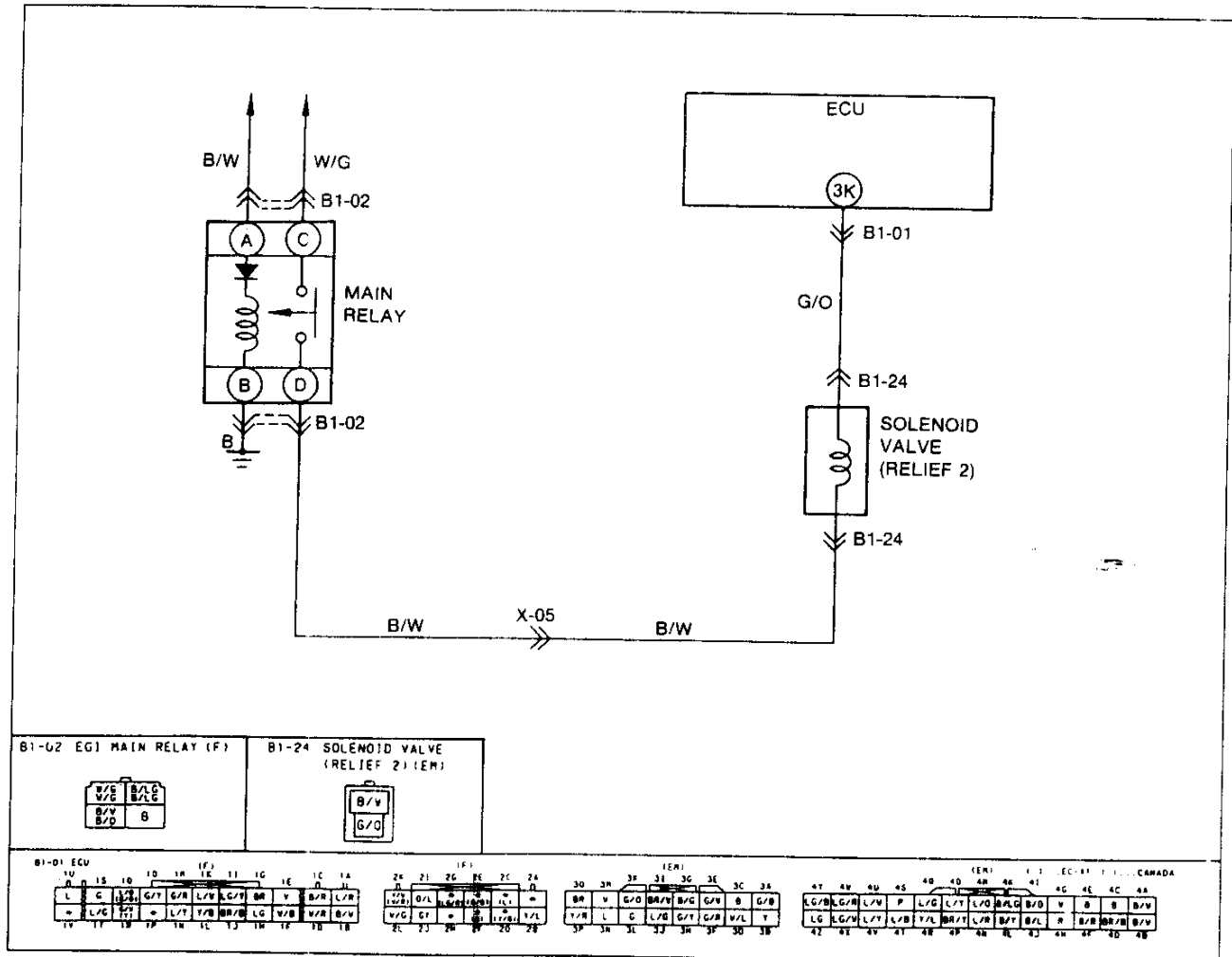

CODE No.		40 (SOLENOID VALVE-PURGE CONTROL [PURGE])	
STEP	INSPECTION	ACTION	
1	Does solenoid valve circuit have a poor connection?	Yes	Repair connector and/or wiring harness
		No	Go to next step
2	Is connector terminal (B/W) voltage OK with solenoid valve connector disconnected?	Yes	Go to next step
		No	Check for open or short circuit in wiring harness (Solenoid valve terminal [B/W]-Main relay terminal [B/W])
3	Is there continuity between solenoid valve terminal (G/Y) and ECU terminal 3H?	Yes	Check for short circuit in wiring harness (Solenoid valve terminal [G/Y]-ECU terminal 3H) ⇨ If OK, go to next step ⇨ If not OK, repair wiring harness
		No	Repair wiring harness
4	Is solenoid valve OK? ⇨ page F-131	Yes	Replace ECU ⇨ page F-15)
		No	Replace solenoid valve

Circuit Diagram

117UDF>066

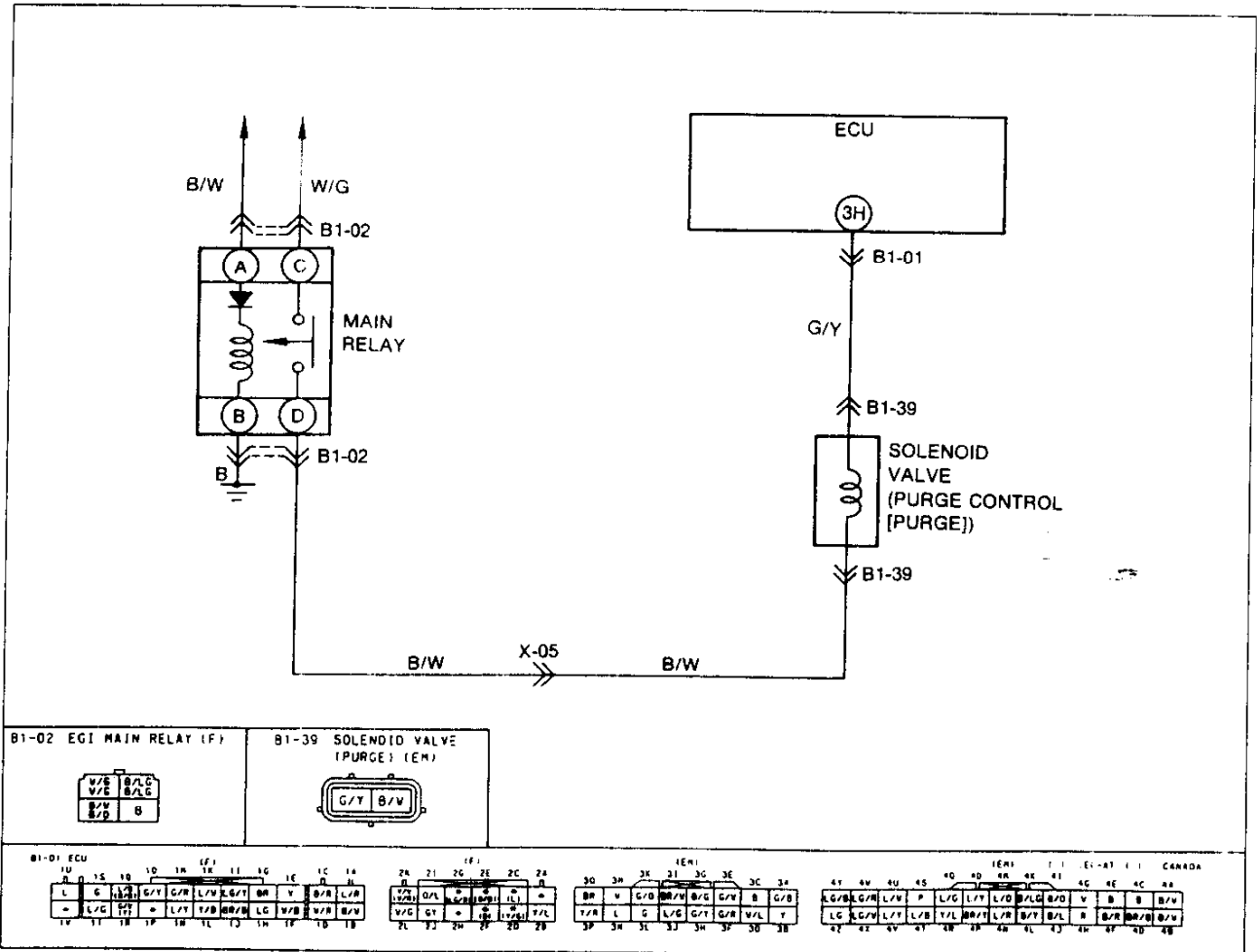

F

SELF-DIAGNOSIS FUNCTION

CODE No.	42 (SOLENOID VALVE-TURBO PRECONTROL)						
STEP	INSPECTION	ACTION					
1	Does solenoid valve circuit have a poor connection?	Yes	Repair connector and/or wiring harness				
		No	Go to next step				
2	Is connector terminal (B/W) voltage OK with solenoid valve connector disconnected? <table border="1" data-bbox="276 420 747 483"><thead><tr><th>Condition</th><th>Voltage</th></tr></thead><tbody><tr><td>Ignition switch ON</td><td>Battery voltage</td></tr></tbody></table>	Condition	Voltage	Ignition switch ON	Battery voltage	Yes	Go to next step
		Condition	Voltage				
		Ignition switch ON	Battery voltage				
No	Check for open or short circuit in wiring harness (Solenoid valve terminal [B/W]-Main relay terminal [B/W])						
3	Is there continuity between solenoid valve terminal (L/Y) and ECU terminal 4V?	Yes	Check for short circuit in wiring harness (Solenoid valve terminal [L/Y]-ECU terminal 4V) ➡ If OK, go to next step ➡ If not OK, repair wiring harness				
No		Repair wiring harness					
4	Is solenoid valve OK? page F-93	Yes	Replace ECU page F-150				
		No	Replace solenoid valve				

17U0FX-0-7

Circuit Diagram

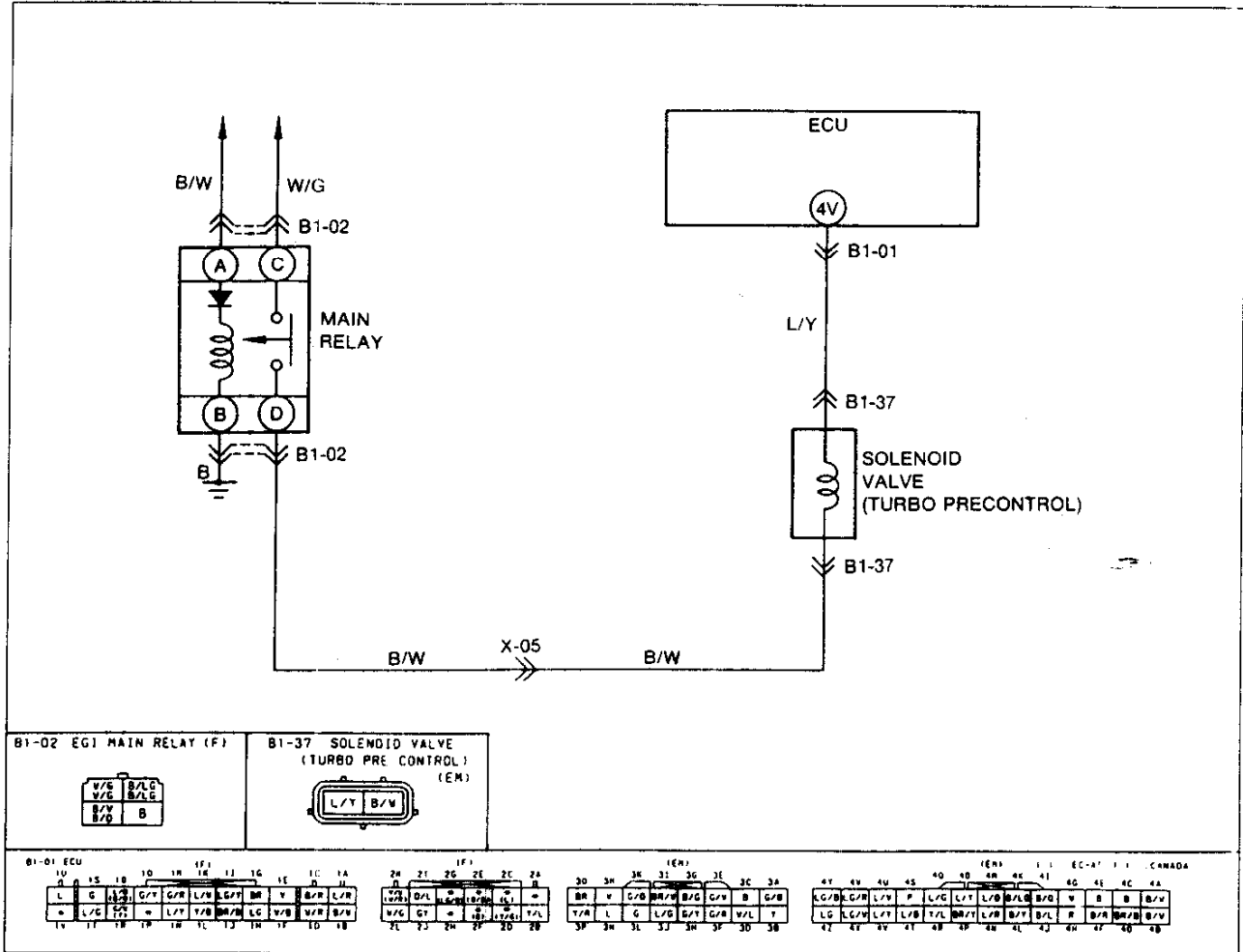

SELF-DIAGNOSIS FUNCTION

F

CODE No.		43 (SOLENOID VALVE-WASTEGATE CONTROL)	
STEP	INSPECTION		ACTION
1	Does solenoid valve circuit have a poor connection?	Yes	Repair connector and/or wiring harness
		No	Go to next step
2	Is connector terminal (B/W) voltage OK with solenoid valve connector disconnected?	Yes	Go to next step
		No	Check for open or short circuit in wiring harness (Solenoid valve terminal [B/W]-Main relay terminal [B/W])
3	Is there continuity between solenoid valve terminal (L/W) and ECU terminal 4U?	Yes	Check for short circuit in wiring harness (Solenoid valve terminal [L/W]-ECU terminal 4U) ➡ If OK, go to next step ➡ If not OK, repair wiring harness
		No	Repair wiring harness
4	Is solenoid valve OK? ☞ page F-93	Yes	Replace ECU ☞ page F-150
		No	Replace solenoid valve

17U0FX-668

Circuit Diagram

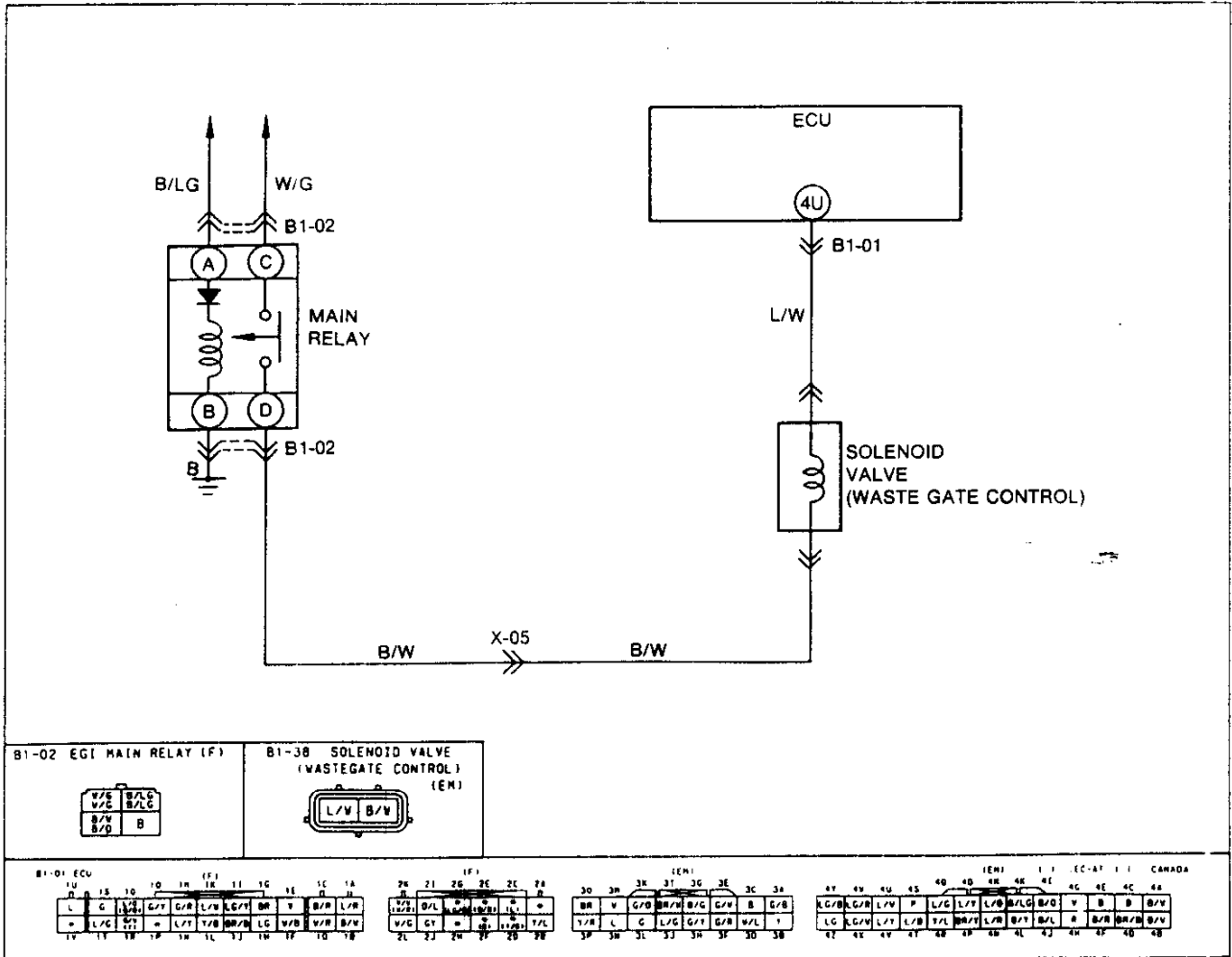

F

SELF-DIAGNOSIS FUNCTION

CODE No.	44 (SOLENOID VALVE-TURBO CONTROL)		
STEP	INSPECTION		ACTION
1	Does solenoid valve circuit have a poor connection?	Yes	Repair connector and/or wiring harness
		No	Go to next step
2	Is connector terminal (B/W) voltage OK with solenoid valve connector disconnected?	Yes	Go to next step
		No	Check for open or short circuit in wiring harness (Solenoid valve terminal [B/W]-Main relay terminal [B/W])
3	Is there continuity between solenoid valve terminal (Y/L) and ECU terminal 4R?	Yes	Check for short circuit in wiring harness (Solenoid valve terminal [Y/L]-ECU terminal 4R) ➡ If OK, go to next step ➡ if not OK, repair wiring harness
		No	Repair wiring harness
4	Is solenoid valve OK? ☞ page F-93	Yes	Replace ECU ☞ page F-150
		No	Replace solenoid valve

17U0FX-Of 9

Circuit Diagram

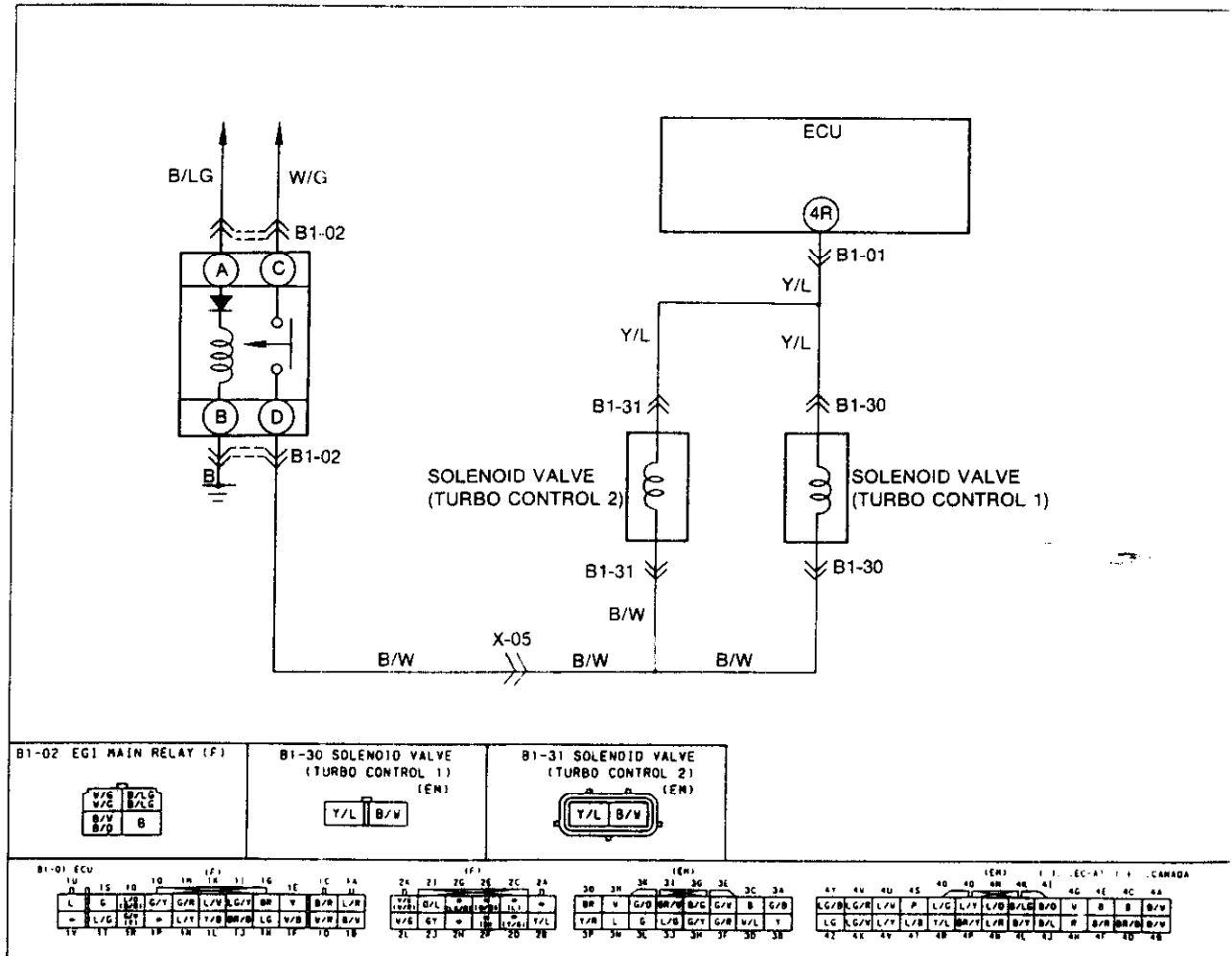

SELF-DIAGNOSIS FUNCTION

F

CODE No.	45 (SOLENOID VALVE-CHARGE CONTROL)		
STEP	INSPECTION	ACTION	
1	Does solenoid valve circuit have a poor connection?	Yes	Repair connector and/or wiring harness
		No	Go to next step
2	Is connector terminal (B/W) voltage OK with solenoid valve connector disconnected?	Yes	Go to next step
		No	Check for open or short circuit in wiring harness (Solenoid valve terminal [B/W]-Main relay terminal [B/W])
3	Is there continuity between solenoid valve terminal (L/B) and ECU terminal 4T?	Yes	Check for short circuit in wiring harness (Solenoid valve terminal [L/B]-ECU terminal 4T) ↳ If OK, go to next step ↳ If not OK, repair wiring harness
		No	Repair wiring harness
4	Is solenoid valve OK? ↗ page F-190	Yes	Replace ECU ↗ page F-150
		No	Replace solenoid valve

17U0FX-170

Circuit Diagram

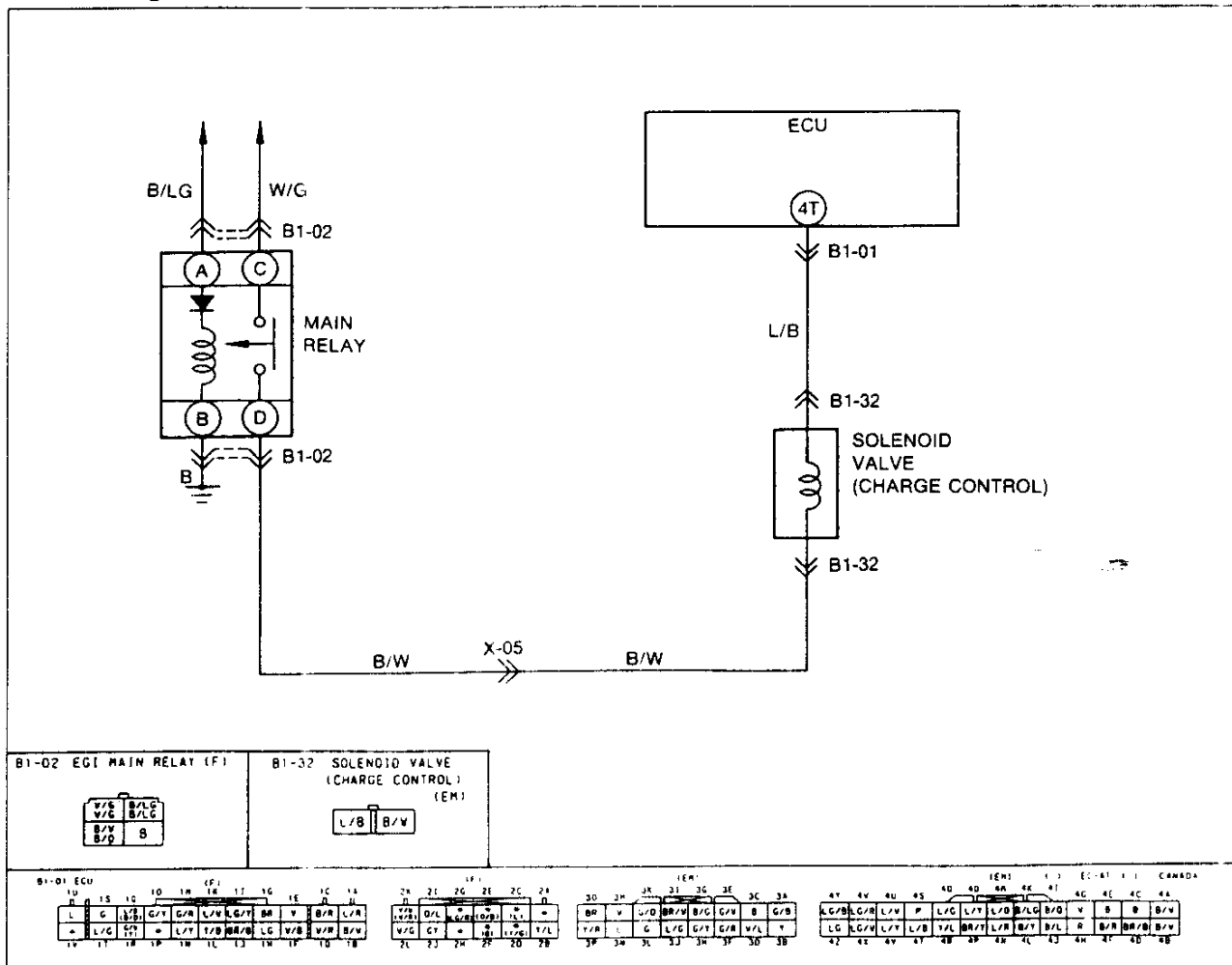

F

SELF-DIAGNOSIS FUNCTION

CODE No.	48 (SOLENOID VALVE-CHARGE RELIEF CONTROL)						
STEP	INSPECTION	ACTION					
1	Does solenoid valve circuit have a poor connection?	Yes	Repair connector and/or wiring harness				
		No	Go to next step				
2	Is connector terminal (B/W) voltage OK with solenoid valve connector disconnected? <table border="1" style="width: 100%; border-collapse: collapse;"> <tr> <th>Condition</th> <th>Voltage</th> </tr> <tr> <td>Ignition switch ON</td> <td>Battery voltage</td> </tr> </table>	Condition	Voltage	Ignition switch ON	Battery voltage	Yes	Go to next step
		Condition	Voltage				
Ignition switch ON	Battery voltage						
3	Is there continuity between solenoid valve terminal (B/R) and ECU terminal 4S?	Yes	Check for short circuit in wiring harness (Solenoid valve terminal [B/R]-Main relay terminal [B/W]) Check for short circuit in wiring harness (Solenoid valve terminal [B/R]-ECU terminal 4S) ➡ If OK, go to next step ➡ If not OK, repair wiring harness				
		No	Repair wiring harness				
4	Is solenoid valve OK? ☞ page F-190	Yes	Replace ECU ☞ page F-150				
		No	Replace solenoid valve				

17U0FX-C71

Circuit Diagram

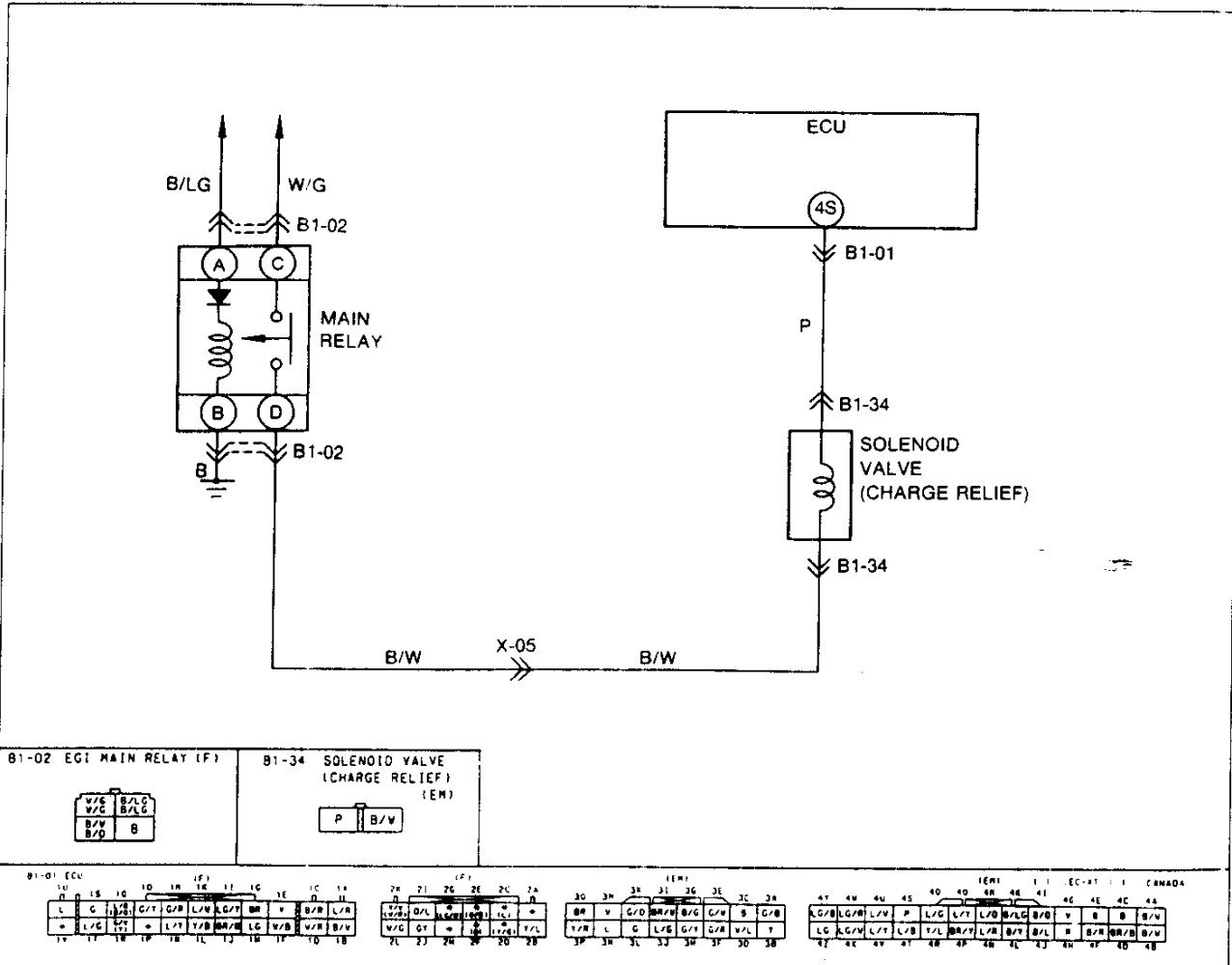

SELF-DIAGNOSIS FUNCTION

F

CODE No.	50 (SOLENOID VALVE-DOUBLE THROTTLE CONTROL)			
STEP	INSPECTION		ACTION	
1	Does solenoid valve circuit have a poor connection?	Yes	Repair connector and/or wiring harness	
		No	Go to next step	
2	Is connector terminal (B/W) voltage OK with solenoid valve connector disconnected?	Yes	Go to next step	
		No	Check for open or short circuit in wiring harness (Solenoid valve terminal [B/W]-Main relay terminal [B/W])	
3	Is there continuity between solenoid valve terminal (B/R) and ECU terminal 30?	Yes	Check for short circuit in wiring harness (Solenoid valve terminal [B/R]-ECU terminal 30) ➡ If OK, go to next step ➡ If not OK, repair wiring harness	
		No	Repair wiring harness	
4	Is solenoid valve OK? ☞ page F-190	Yes	Replace ECU	☞ page F-150
		No	Replace solenoid valve	

17U0FX-372

Circuit Diagram

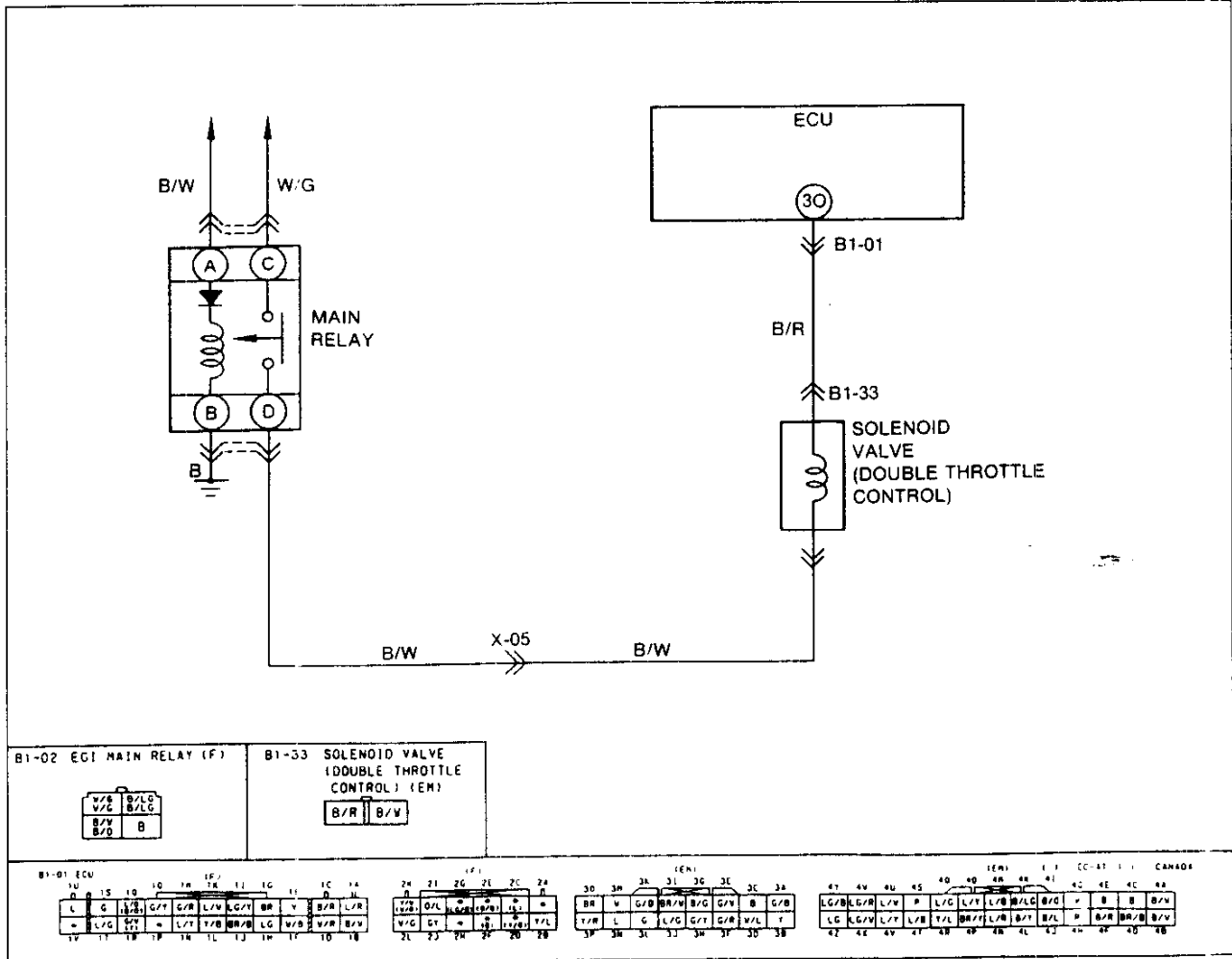

SELF-DIAGNOSIS FUNCTION

F

CODE No.	54 (AIR PUMP RELAY)						
STEP	INSPECTION	ACTION					
1	Does air pump relay circuit have a poor connection?	Yes	Repair connector and/or wiring harness				
		No	Go to next step				
2	Is connector terminal (B/W) voltage OK with airpump relay connector disconnected?	Yes	Go to next step				
		No	Check for open or short circuit in wiring harness (airpump relay [B/W]-Main relay terminal [B/W])				
<table border="1" style="width: 100%; border-collapse: collapse;"> <thead> <tr> <th style="text-align: center;">Condition</th> <th style="text-align: center;">Voltage</th> </tr> </thead> <tbody> <tr> <td style="text-align: center;">Ignition switch ON</td> <td style="text-align: center;">Battery voltage</td> </tr> </tbody> </table>		Condition	Voltage	Ignition switch ON	Battery voltage		
Condition	Voltage						
Ignition switch ON	Battery voltage						
3	Is there continuity between airpump relay terminal (G/Y) and ECU terminal 2J?	Yes	Check for short circuit in wiring harness (Airpump relay [G/Y]-ECU terminal 2J) ➡ If OK, go to next step ➡ If not OK, repair wiring harness				
		No	Repair wiring harness				
4	Is air pump relay OK? ➡ page F-122	Yes	Replace ECU ➡ page F-150				
		No	Replace airpump relay				

17U0FX-374

Circuit Diagram

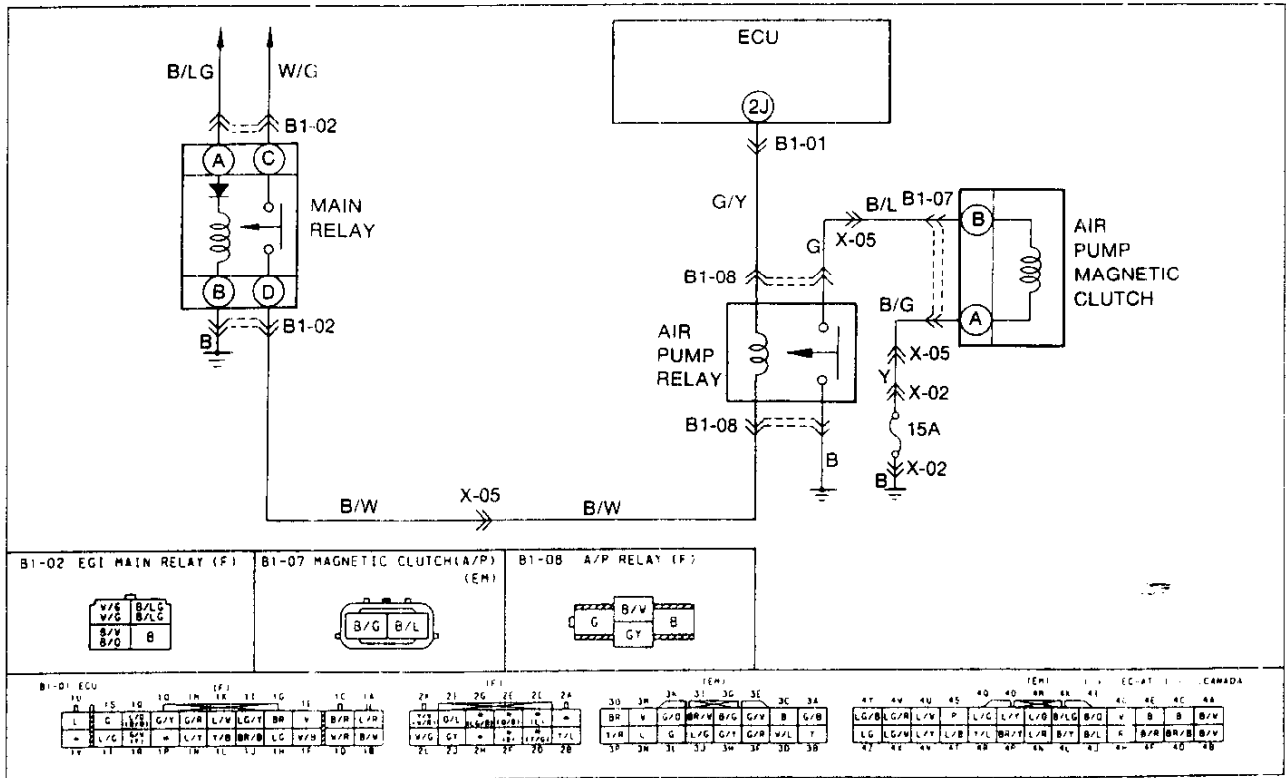

F

SELF-DIAGNOSIS FUNCTION

CODE No.	71 (INJECTOR [FRONT SECONDARY])							
STEP	INSPECTION		ACTION					
1	Does injector circuit have a poor connection?		Yes	Repair connector and/or wiring harness				
			No	Go to next step				
2	Is connector terminal (B/Y) voltage OK with injector connector disconnected? <table border="1"> <tr> <th>Condition</th> <th>Voltage</th> </tr> <tr> <td>Ignition switch ON</td> <td>Battery voltage</td> </tr> </table>		Condition	Voltage	Ignition switch ON	Battery voltage	Yes	Go to next step
			Condition	Voltage				
Ignition switch ON	Battery voltage							
		No	Check for open or short circuit in wiring harness (injector terminal 4X [B/Y]-Main relay terminal [B/O])					
3	Is injector resistance OK? Resistance: 13.5 Ω (20°C [68°F])		Yes	Go to next step				
			No	Replace injector				
4	Is there continuity between injector terminal and ECU terminal? <table border="1"> <tr> <th>INJECTOR</th> <th>ECU</th> </tr> <tr> <td>Front (LG/W)</td> <td>4X</td> </tr> </table>		INJECTOR	ECU	Front (LG/W)	4X	Yes	Check for short circuit in wiring harness injector to ECU ➡ If OK, go to next step ➡ If not OK, repair wiring harness
			INJECTOR	ECU				
Front (LG/W)	4X							
		No	Repair wiring harness					
5	Disconnect negative battery cable for at least 20 seconds Connect battery cable and recheck for service code Is service code displayed?		Yes	Replace ECU ➡ page F-150				
			No	Intermittent poor connection Check for cause				

17U0FX-0/5

Circuit Diagram

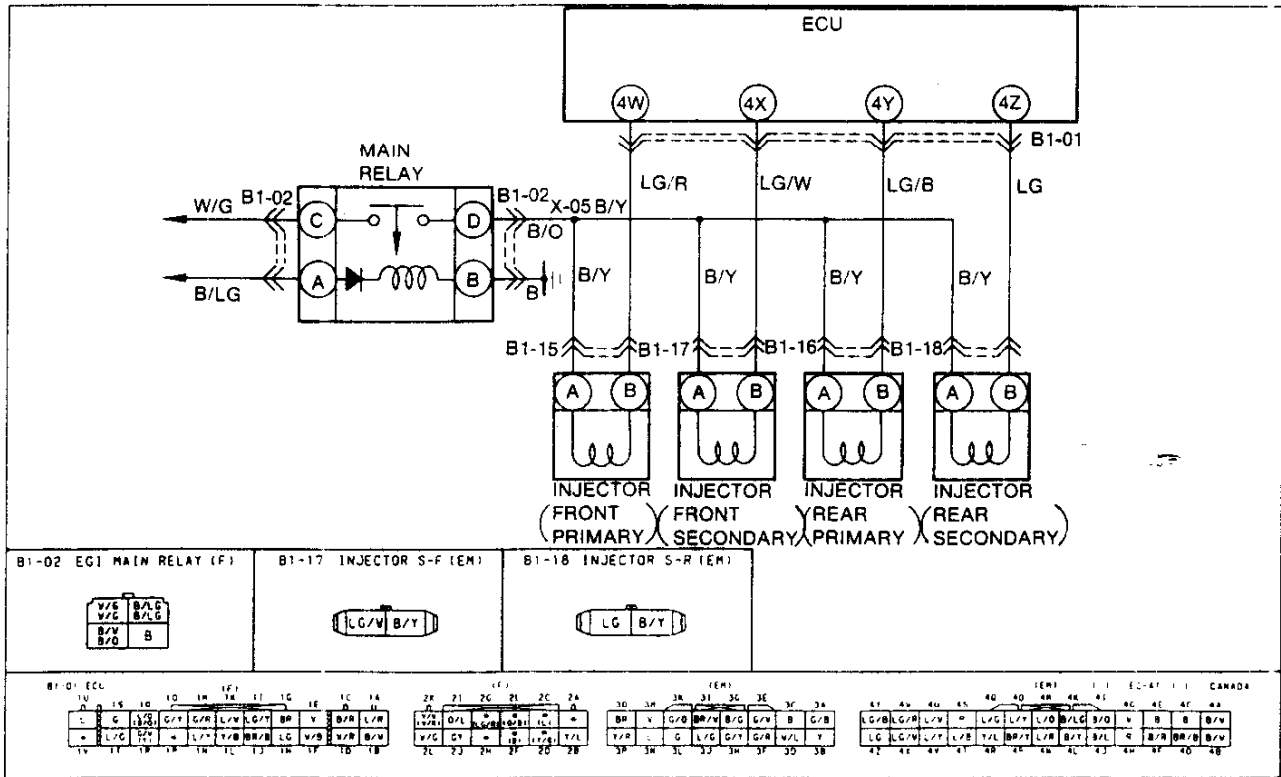

SELF-DIAGNOSIS FUNCTION

CODE No.	73 (INJECTOR (REAR SECONDARY))						
STEP	INSPECTION		ACTION				
1	Does injector circuit have a poor connection?	Yes	Repair connector and/or wiring harness				
		No	Go to next step				
2	Is connector terminal (B/Y) voltage OK with injector connector disconnected?	Yes	Go to next step				
		No	Check for open or short circuit in wiring harness (injector terminal 4Z [B/Y] Main relay terminal [B/O])				
3	Is injector resistance OK? Resistance: 13.8 Ω (20°C [68°F])	Yes	Go to next step				
		No	Replace injector				
4	Is there continuity between injector terminal and ECU terminal? <table border="1" style="margin: 5px auto; border-collapse: collapse;"> <tr> <td style="text-align: center;">INJECTOR</td> <td style="text-align: center;">ECU</td> </tr> <tr> <td style="text-align: center;">Rear (LG)</td> <td style="text-align: center;">4Z</td> </tr> </table>	INJECTOR	ECU	Rear (LG)	4Z	Yes	Check for short circuit in wiring harness Injector to ECU ⇨ If OK, go to next step ⇨ If not OK, repair wiring harness
		INJECTOR	ECU				
Rear (LG)	4Z						
No	Repair wiring harness						
5	Disconnect negative battery cable for at least 20 seconds Connect battery cable and recheck for service code Is service code displayed?	Yes	Replace ECU ⇨ page F-150				
		No	Intermittent poor connection Check for cause				

17U0FX-(75)

Circuit Diagram

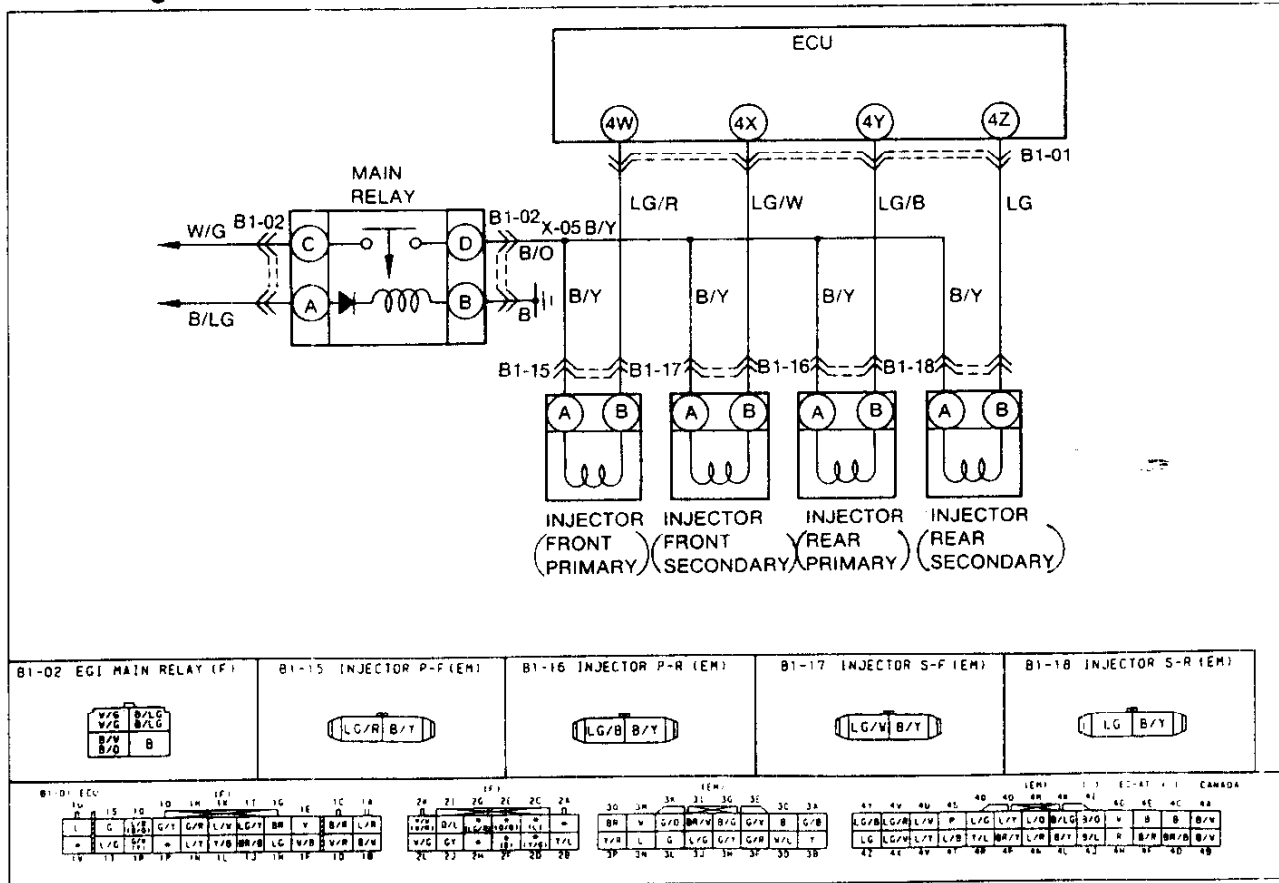

F

SELF-DIAGNOSIS FUNCTION

Code No.	76 (SLIP LOCKUP OFF SIGNAL)		
STEP	INSPECTION	ACTION	
1	Is there poor connection in Lockup off signal circuit between ECU and EC-AT CU?	Yes	Repair or replace connector
		No	Go to next step
2	Is there continuity between ECU terminal 2G and EC-AT CU terminal 2H	Yes	Go to next step
		No	Check for open circuit in wiring from EC-AT CU to ECU
3	Is EC-AT CU terminal 2H voltage OK?	Yes	Go to next step
		No	Check for cause ☞ page F-156
4	Is ECU terminal 2G voltage OK?	Yes	Replace ECU ☞ page F-150
		No	Check for short circuit in wiring from EC-AT CU to ECU

17U0PX 177

Circuit Diagram

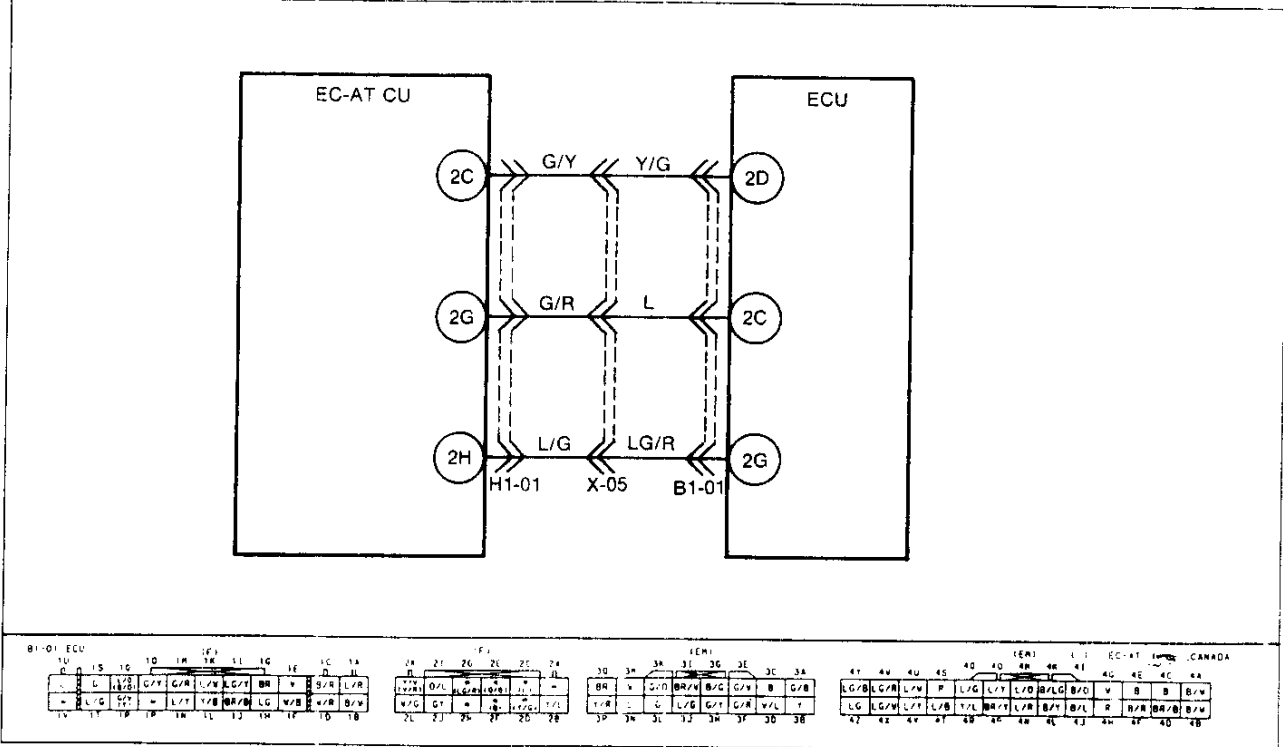

SELF-DIAGNOSIS FUNCTION

F

Code No.	77 (TORQUE REDUCED SIGNAL)		
STEP	INSPECTION		ACTION
1	Is there poor connection in Torque reduced signal circuit between ECU and EC-AT CU?	Yes	Repair or replace connector
		No	Go to next step
2	Is there continuity between ECU terminal 2D and EC-AT CU terminal 2C?	Yes	Go to next step
		No	Check for open circuit in wiring from EC-AT CU to ECU
3	Is EC-AT CU terminal 2C voltage OK?	Yes	Go to next step
		No	Check for cause ☞ page F-156
4	Is ECU terminal 2D voltage OK?	Yes	Replace ECU ☞ page F-150
		No	Check for short circuit in wiring from EC-AT CU to ECU

17U0FX 376

Circuit Diagram

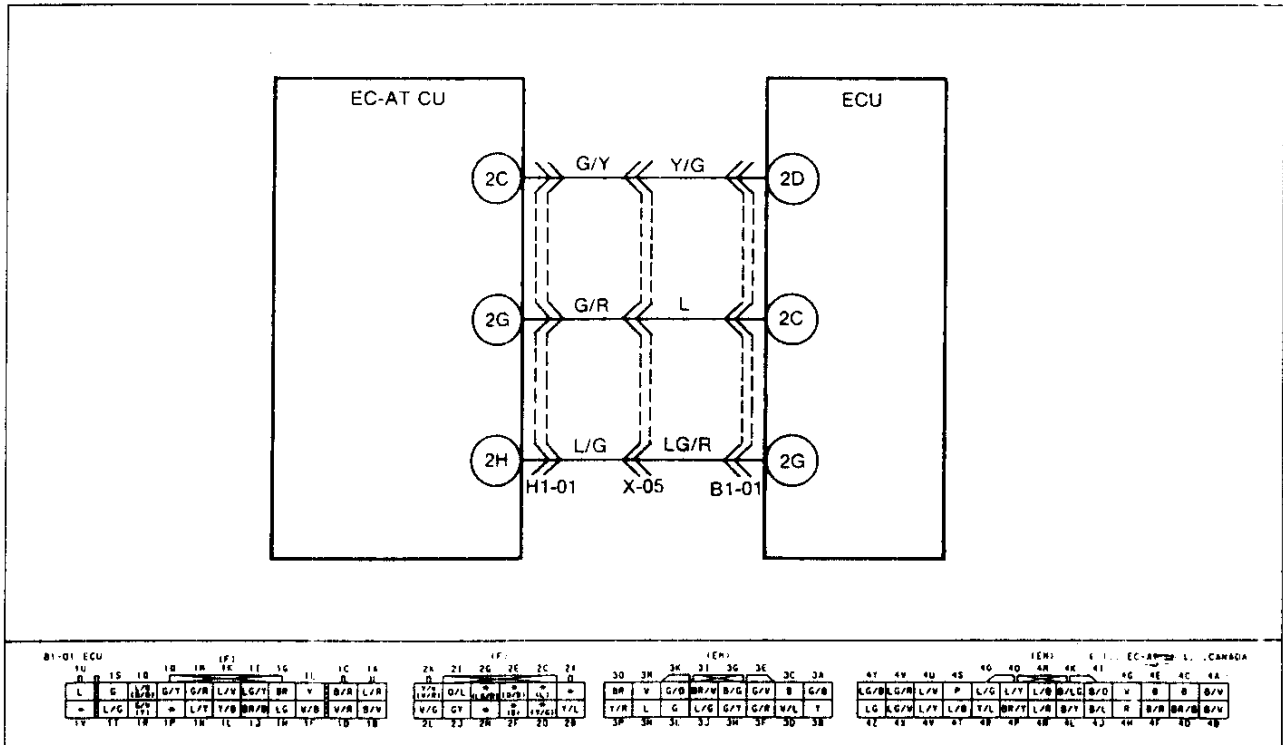

F

SELF-DIAGNOSIS FUNCTION

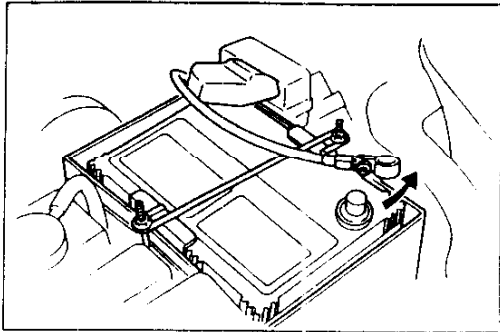

17U0FX-079

After-repair Procedure

Cancel the memory of service code number by disconnecting the negative battery cable for **20 sec** and depress the brake pedal. Reconnect the negative battery cable

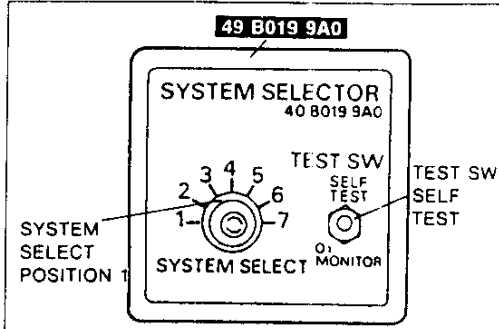

17U0FX-080

Self-diagnosis Checker

1. Connect the **SST** (System Selector) to the diagnosis connector.
2. Set system select to position 1.
3. Set the test switch to SELF TEST.

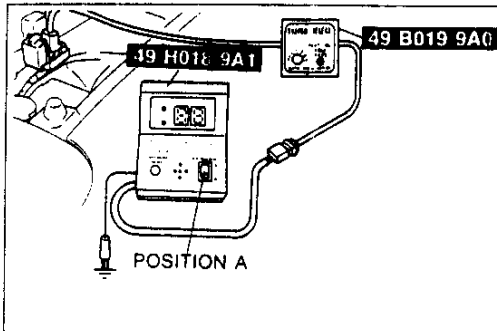

17U0FX-081

4. Connect the **SST** (Self-Diagnosis Checker) to the System Selector and a ground.
5. Set the select of the Self-Diagnosis Checker to position A.
6. Turn the ignition switch ON.
7. Verify that no service code numbers are displayed.

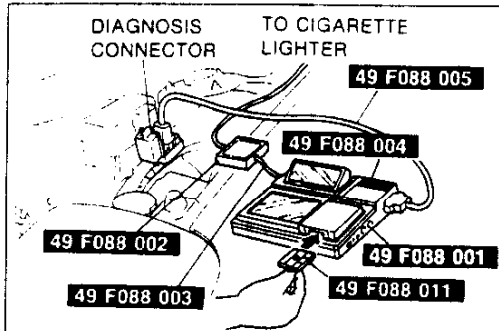

17U0FX-082

DT-S1000

1. Connect the **SST** (DT-S1000) to the diagnosis connector.
2. Select Service code check.
3. Turn the ignition switch ON.

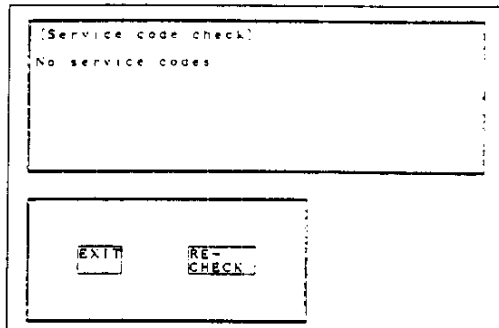

17U0FX-083

4. Verify that no service code numbers are displayed.

SWITCH MONITOR FUNCTION

Individual switches can be inspected by the **SST** (Self-Diagnosis Checker or DT-S1000)

Note

- The **TEN** terminal of the diagnosis connector must be grounded and the ignition switch **CN** (engine stopped).
- If either switch remains activated, the monitor lamp will be illuminated.

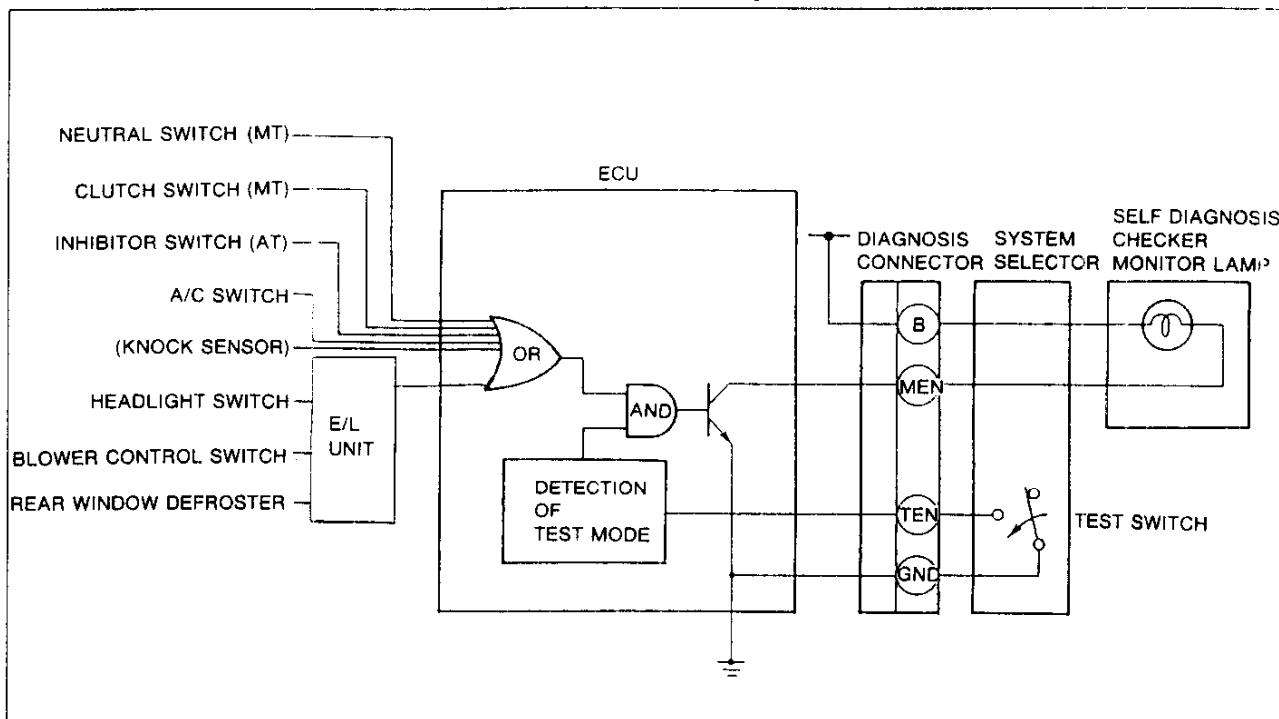

17U0FX-CB4

Switch	Self-Diagnosis Checker (Monitor lamp)		Remarks
	Light ON	Light OFF	
Clutch switch (MT)	Pedal released	Pedal depressed	In gear
Neutral switch (MT)	In gear	Neutral	Clutch pedal released
Inhibitor switch (AT)	L, S, D or R range	N or P range	--
Headlight switch	ON	OFF	Headlight switch I or II position
Blower switch	ON	OFF	At 3rd or 4th position
Rear window defroster switch	ON	OFF	--
A/C switch	ON	OFF	Blower switch at 1st or higher position

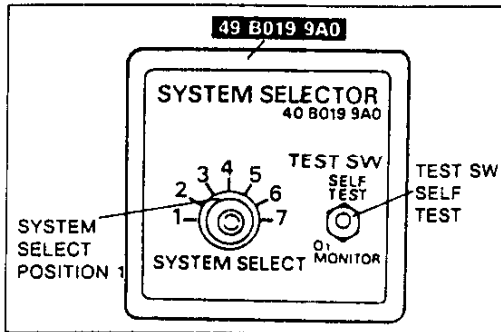

17U0FX-085

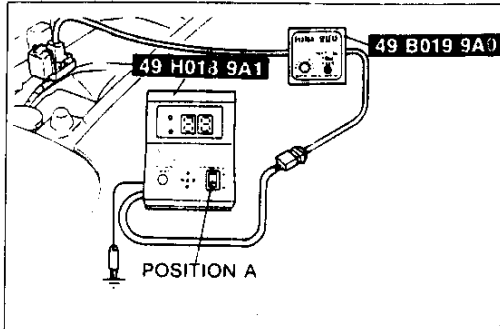

17U0FX-086

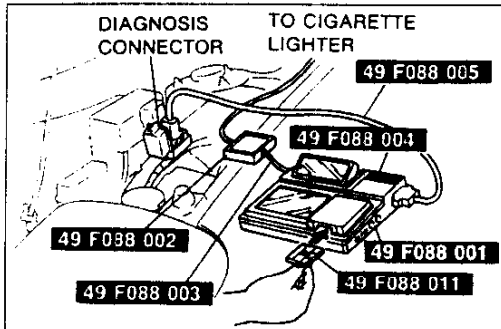

17U0FX-087

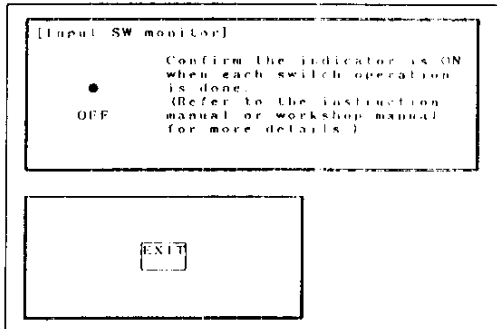

17U0FX-088

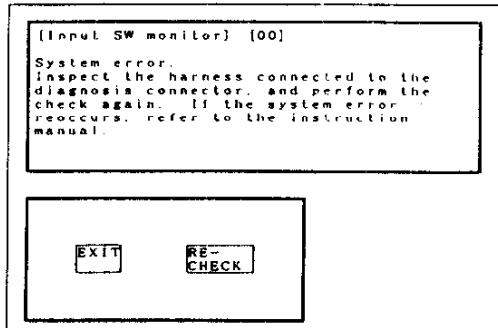

**Inspection Procedure
Self-Diagnosis Checker**

1. Connect the **SST** (System Selector) to the diagnosis connector.
2. Set system select to position 1.
3. Set TEST SW to SELF-TEST.

4. Connect the **SST** (Self-Diagnosis Checker) to the System Selector and a ground.
5. Set the select switch of the Self-Diagnosis Checker to position A.
6. Turn the ignition switch ON.
7. Check if the Monitor Lamp illuminates when each switch is made to function as described.

Caution

- If either switch remains activated, the monitor lamp will be illuminated.
- Do not start the engine.

DT-S1000

1. Connect the **SST** (DT-S1000) to the diagnosis connector.
2. Select switch monitor check.
3. Turn ignition switch ON.

4. Check if the Monitor indicator turn black to white when each switch is made to function as described.

Caution

- If the DT-S1000 detects a system error as a result of diagnosis, the display on the left will appear.
- If this message appears refer to the instruction manual.
- Press EXIT to return function selection display.

Procedure

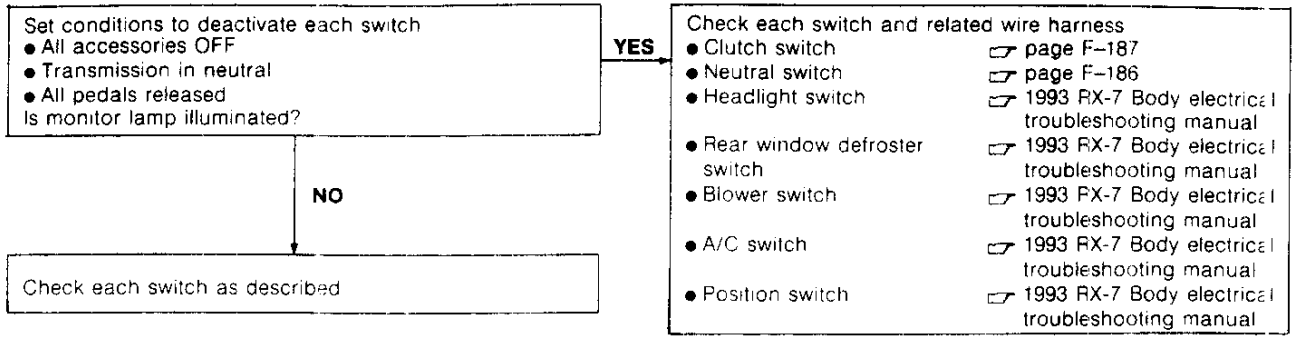

16E0F2-63

Neutral switch (MT)

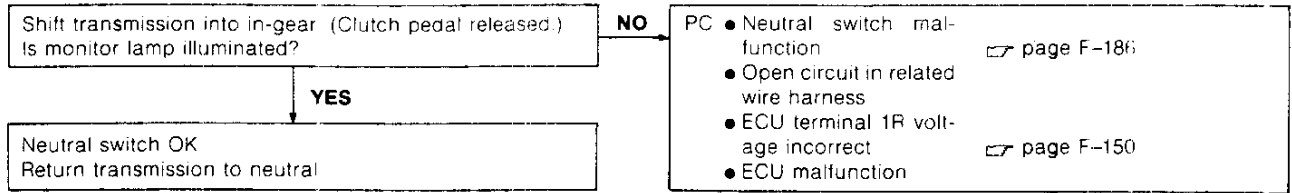

Clutch switch (MT)

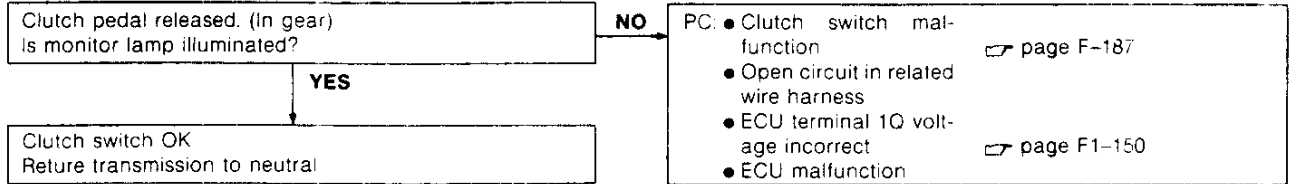

F

SELF-DIAGNOSIS FUNCTION

A/C switch

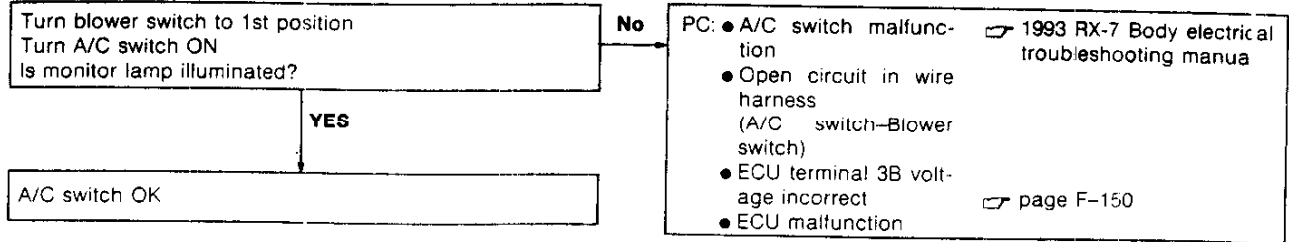

16E0F2-090

Rear window defroster switch

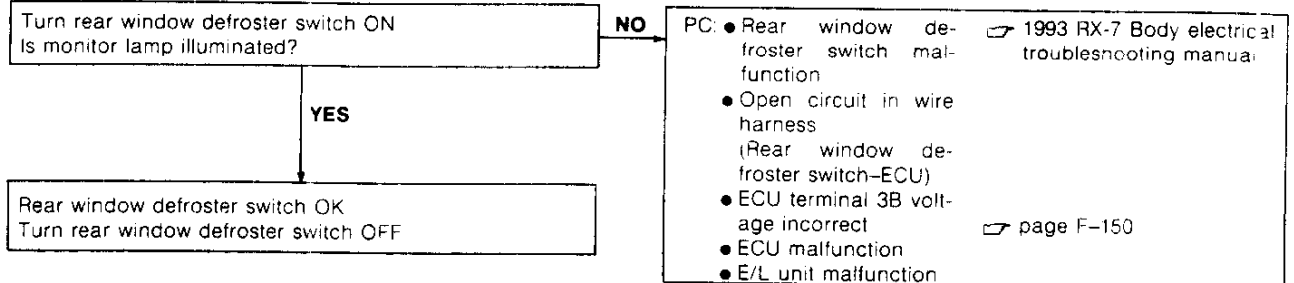

16E0F2-091

Inhibitor switch (AT)

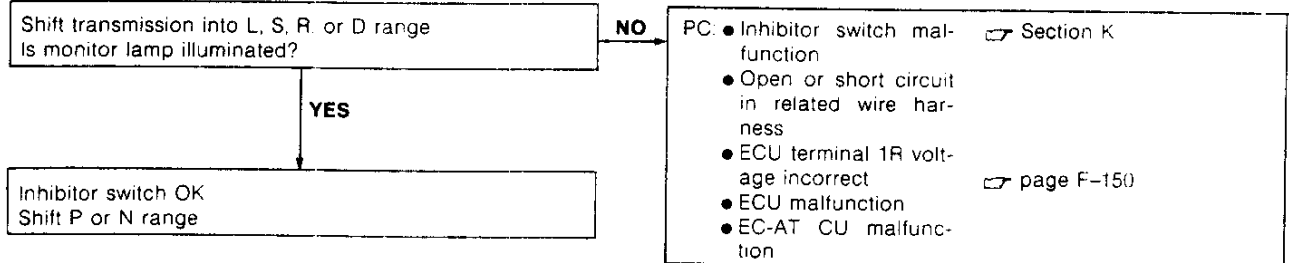

16E0F2-092

Blower switch

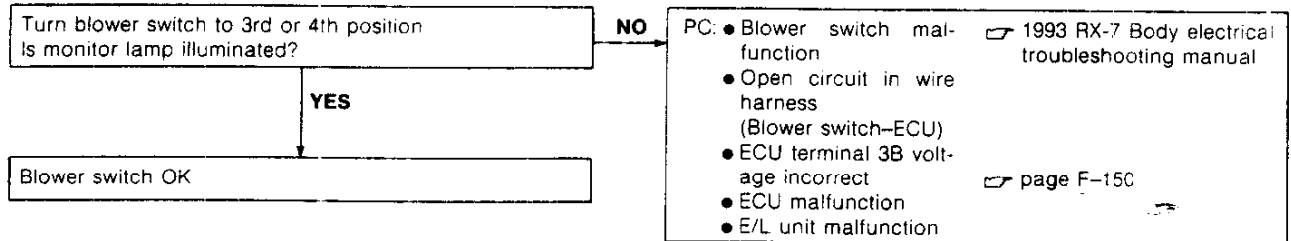

16E0F2-039

OXYGEN SENSOR MONITOR FUNCTION

Engine Signal Monitor

With the **SST** see to O₂ Monitor, the oxygen sensor is monitored by the Self-Diagnosis checker as described.

Condition		Item monitored	Function
Engine	System selector switch		
Running	O ₂ monitor	Oxygen sensor output signal	Oxygen sensor output more than 0.45 V Monitor lamp: Flashes

DT-S1000

With the DT-S1000 monitor check, the oxygen sensor signal is displayed as graph.

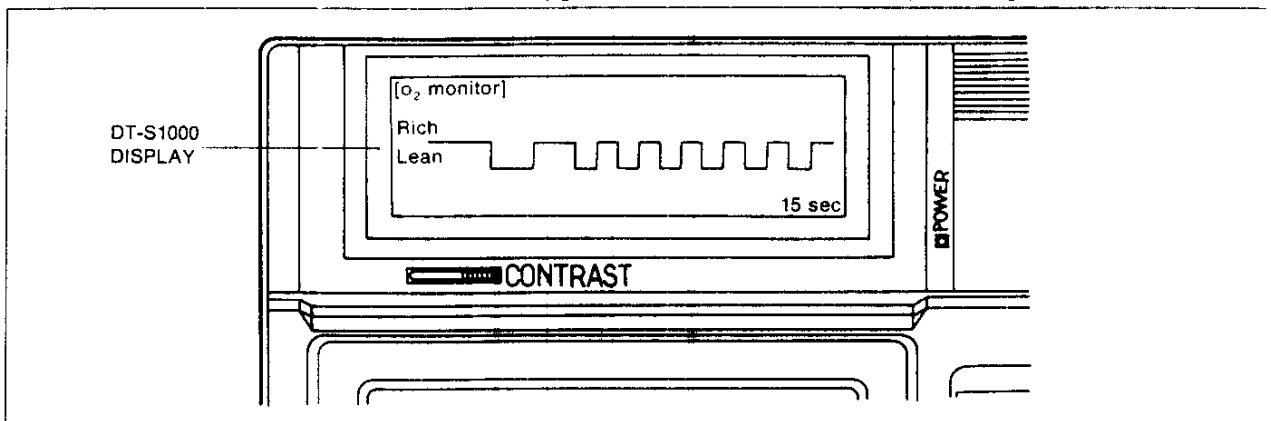

KNOCK SENSOR MONITOR FUNCTION

With the System selector set to Engine Signal Monitor. SELF-TEST the knock sensor is monitored by the Self-Diagnosis checker as described below.

Item monitored	Condition			Function
	Test	Ignition switch	System selector switch	
Knock sensor output signal	Tap the engine hanger lightly with hammer	ON	SELF-TEST	Monitor lamp: Flashes

DT-S1000

With the DT-S1000 at input Switch monitor check, operation of the knock sensor is monitored and displayed.

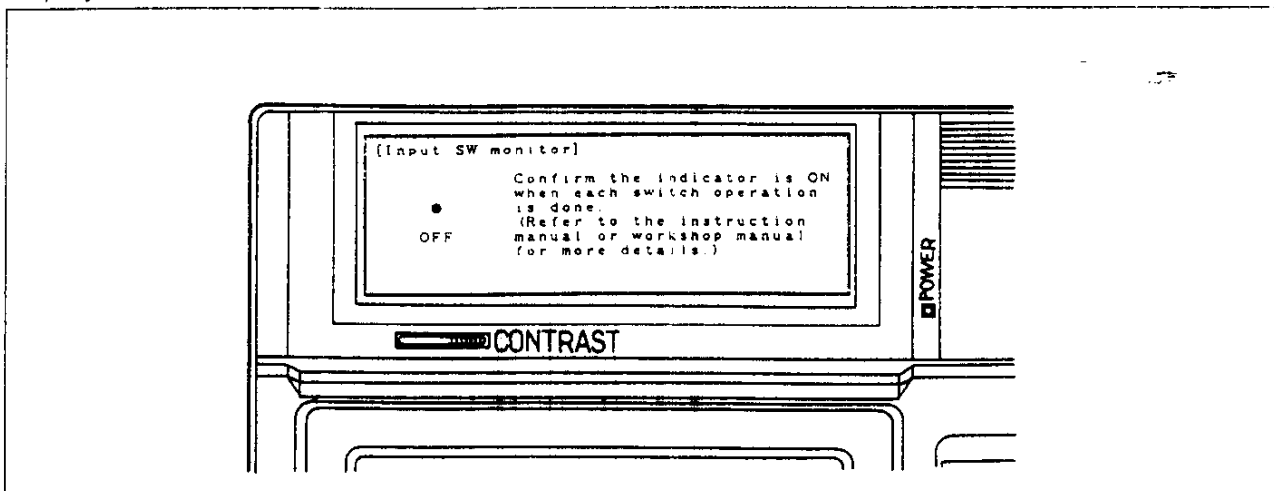

REAL TIME MONITOR FUNCTION (DT-S1000)

Individual input output signal can be inspected by the SST (DT-S1000).

Signal	Monitor Item	Unit	Remark	
BASIC	Engine speed	[rpm]		
	Intake air pressure	[kPa]		
	Throttle opening amount (Narrow range)	[V]		
	Throttle opening amount (Full range)	[V]		
	Engine coolant temperature	[°C]		
	Solenoid valve (ISC)	[%]	Duty control	
	Battery voltage	[V]		
	Ignition timing (IGT-L)	[BTDC°]		
	Ignition timing (IGT-T)	[BTDC°]		
	Injection drive signal (Primary)	[m sec]		
Injector drive signal (Secondary)	[m sec]			
INPUT	Oxygen sensor voltage	[V]		
	Intake air temperature	[°C]		
	Fuel temperature	[°C]		
	Atmospheric pressure (in ECU)	[kPa]	in ECU	
	Vehicle speed	[km/h]		
	MOP position (target figure)	[V]		
	MOP position sensor	[V]	Target figure	
	Power steering pressure signal	[ON/OFF]		
	Starter signal	[ON/OFF]		
	Brake signal	[ON/OFF]		
	A/C signal	[ON/OFF]		
	E/L signal	[ON/OFF]		
	Heat hazard signal	[ON/OFF]		
	Canada switch (Canada only)	[ON/OFF]		
	DRL signal (Canada only)	[ON/OFF]		
	California switch (California only)	[ON/OFF]		
	EGR switch signal (California only)	[ON/OFF]		
	Neutral signal	[ON/OFF]		
	Clutch signal	[ON/OFF]	MT only	
	1st gear signal	[ON/OFF]		
	2nd gear signal	[ON/OFF]		
	Inhibitor signal	[ON/OFF]	AT only	
	Reduce torque signal	[ON/OFF]		
	Slip lock-up signal	[ON/OFF]		
Shift solenoid A signal	[ON/OFF]			
Shift solenoid B signal	[ON/OFF]			
OUTPUT	Solenoid valve	Solenoid valve (Turbo precontrol)	[%]	
		Solenoid valve (Wastegate control)	[%]	
		Solenoid valve (Purge control)	[%]	Duty control
		Solenoid valve (Charge relief)	[ON/OFF]	
		Solenoid valve (Charge control)	[ON/OFF]	
		Solenoid valve (Turbo control)	[ON/OFF]	
		Solenoid valve (Switching)	[ON/OFF]	
		Solenoid valve (Relief1)	[ON/OFF]	Secondary air injection system
		Solenoid valve (Relief2)	[ON/OFF]	
		Solenoid valve (Port air bypass)	[ON/OFF]	
		Solenoid valve (Split air bypass)	[ON/OFF]	
		Solenoid valve (Pressure regulator control)	[ON/OFF]	Sequential twin turbo-charger control system
		Solenoid valve (Double throttle control)	[ON/OFF]	
		Solenoid valve (Exhaust gas recirculation)	[ON/OFF]	
	Solenoid valve (Accelerated warm-up system)	[ON/OFF]		
	Relay	Electric cooling fan relay	[ON/OFF]	
		A/C relay	[ON/OFF]	
		Air pump relay	[ON/OFF]	
		Fuel pump relay	[ON/OFF]	
	Signal	Torque reduced signal	[ON/OFF]	
Slip lock up OFF signal		[ON/OFF]	AT only	
Idle signal		[ON/OFF]		

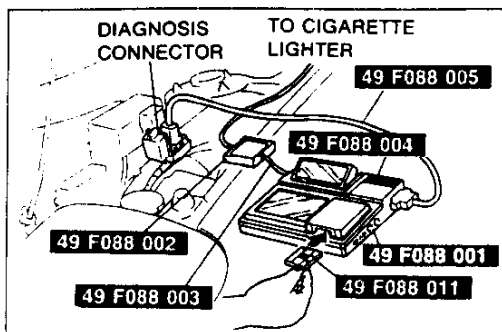

Inspection Procedure

1. Connect the **DT-S1000** to the diagnosis connector as shown in figure.

2. Select the real time monitor from the **DT-S1000** display.
3. Turn ignition switch ON.

Caution

● Do not turn the ignition switch OFF until real time monitor is completed.

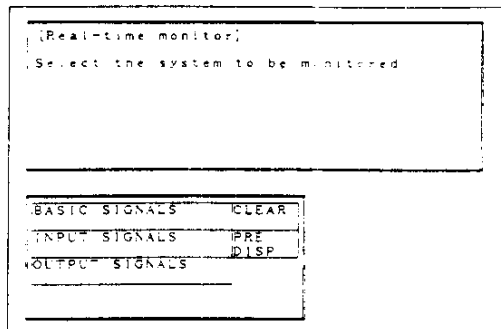

4. Select the inspection items.

Note

● The maximum selection items are 8.
● Basic Input signal need two-channel, therefore if all selection items basic signal, The maximum selection item is 4.

5. Verify indication of respective data item in each condition, referring to ECU terminal condition chart. (Refer to page F-166)

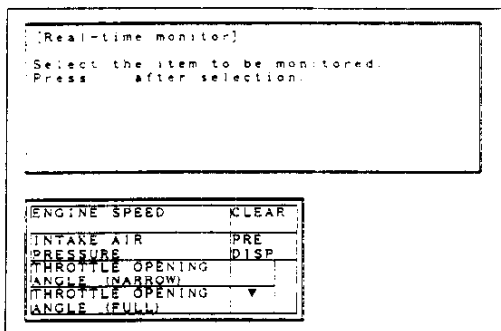

<Example>

When checking the of throttle sensor operation pattern at engine speed and intake air pressure, the following steps are available.

Step 1.

Select the engine speed, intake air pressure and Thro- liesensor from Basic signal.

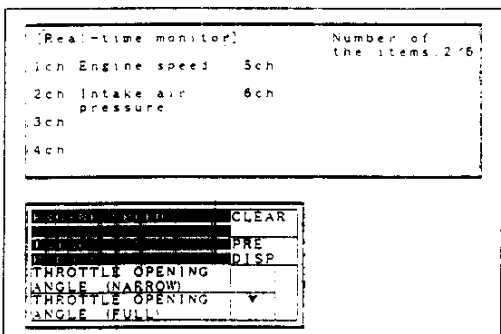

Step 2.

Drive the vehicle and verify that the engine speed (rpm), intake air pressure (kPa), Throttlesensor output voltage (V) on the display.

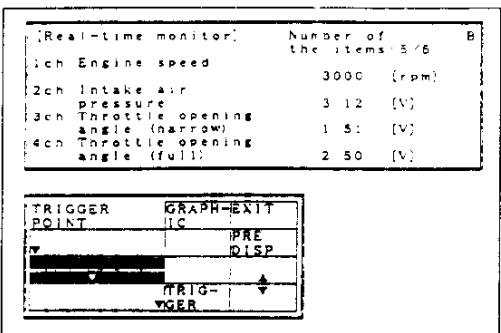

Note

● Referring to the DT-S1000 instruction manual.

F

SELF-DIAGNOSIS FUNCTION

SIMULATION FUNCTION (DT-S1000)

By using the simulation function, the following solenoid valves and relays can be externally driven. This function allows easy system checking.

Check condition	Simulation Item	Operation
Ign ON	Solenoid valve (Turbo precontrol)	Driven with duty value of 50%
	Solenoid valve (Wastegate control)	Driven with duty value of 50%
	Solenoid valve (PURGE control)	Driven with duty value of 50%
	Solenoid valve (Charge relief)	ON/OFF
	Solenoid valve (Charge control)	ON/OFF
	Solenoid valve (Turbo control)	ON/OFF
	Solenoid valve (Switching)	ON/OFF
	Solenoid valve (Relief1)	ON/OFF
	Solenoid valve (Relief2)	ON/OFF
	Solenoid valve (Port air bypass)	ON/OFF
	Solenoid valve (Split air bypass)	ON/OFF
	Solenoid valve (Pressure regulator control)	ON/OFF
	Solenoid valve (Double throttle control)	ON/OFF
	Solenoid valve (Exhaust gas recirculation)	ON/OFF
	Solenoid valve (Accelerated warm-up system)	ON/OFF
	Electric cooling fan relay	ON/OFF
	A/C relay	ON/OFF
	Air pump relay	ON/OFF
	F/P relay	ON/OFF
Idling	Injector (Front Primary)	Stopped
	Injector (Rear Primary)	Stopped
	Injector (Front primary)	Driven with 1 to 30% increase or decrease injection time
	Injector (Rear primary)	Driven with 1 to 30% increase or decrease injection time
	Solenoid valve (Idle speed control [ISC])	Driven with any duty value
	Solenoid valve (Purge Control)	Driven with any duty value
	Solenoid valve (Charge control)	ON/OFF
	Solenoid valve (Turbo control)	ON/OFF
	Solenoid valve (Switching)	ON/OFF
	Solenoid valve (Relief1)	ON/OFF
	Solenoid valve (Pressure regulation control)	ON/OFF
	Solenoid valve (Double throttle control)	ON/OFF
	Solenoid valve (Exhaust gas recirculation [EGR])	ON/OFF
	Solenoid valve (Accelerated warm-up system [AWS])	ON/OFF
	A/C relay	ON/OFF
	Air Pump relay	ON/OFF

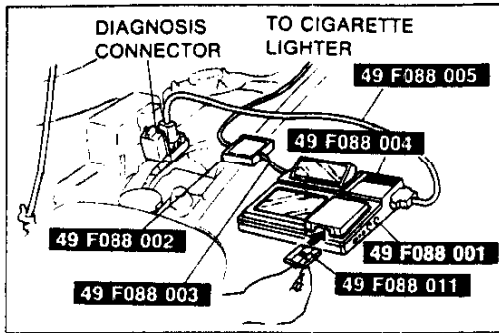

Inspection Procedure

1. Connect the **DT-S1000** to the diagnosis connector as shown in figure.

2. Select the simulation function from the **DT-S1000** display.

3. Turn ignition switch ON.

Caution

- Do not turn the ignition switch OFF until simulation check is completed.

4. Select the check condition and simulation item.

Note

- Selection item is 1.

5. Start the engine, if necessary.

6. Verify operation (sound, engine condition, etc.) when solenoid valve or relay is ON.

Note

- If the DT-S1000 displays "Communication error", inspect the harness connected to the diagnosis connector, and perform the check again.
- Referring to the DT-S1000 instruction manual.

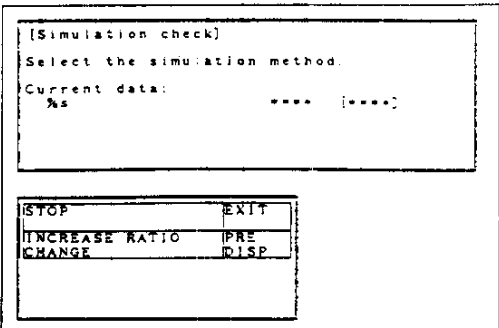
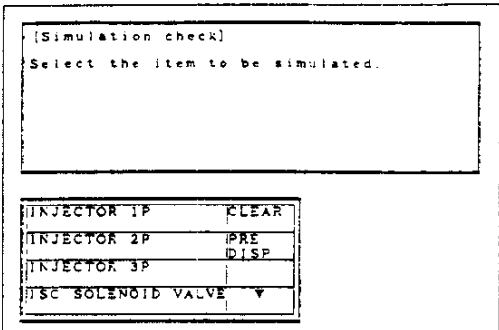
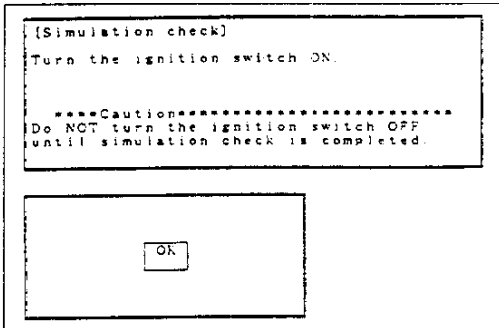
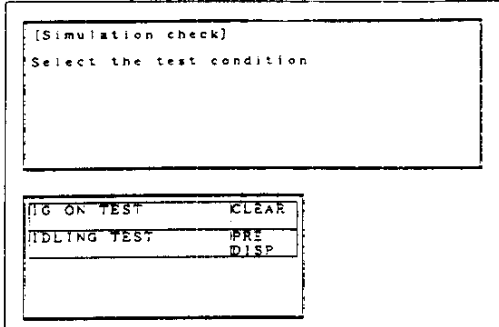

F

INTAKE AIR SYSTEM

INTAKE AIR SYSTEM

COMPONENT PARTS

Removal / Inspection / Installation

1. Remove in the order shown in the figure, referring **Removal Note** (Refer to page F-77).
2. Inspect all parts and repair or replace as necessary.
3. Install in the reverse order of removal, referring to **Installation Note** (Refer to page F-77).

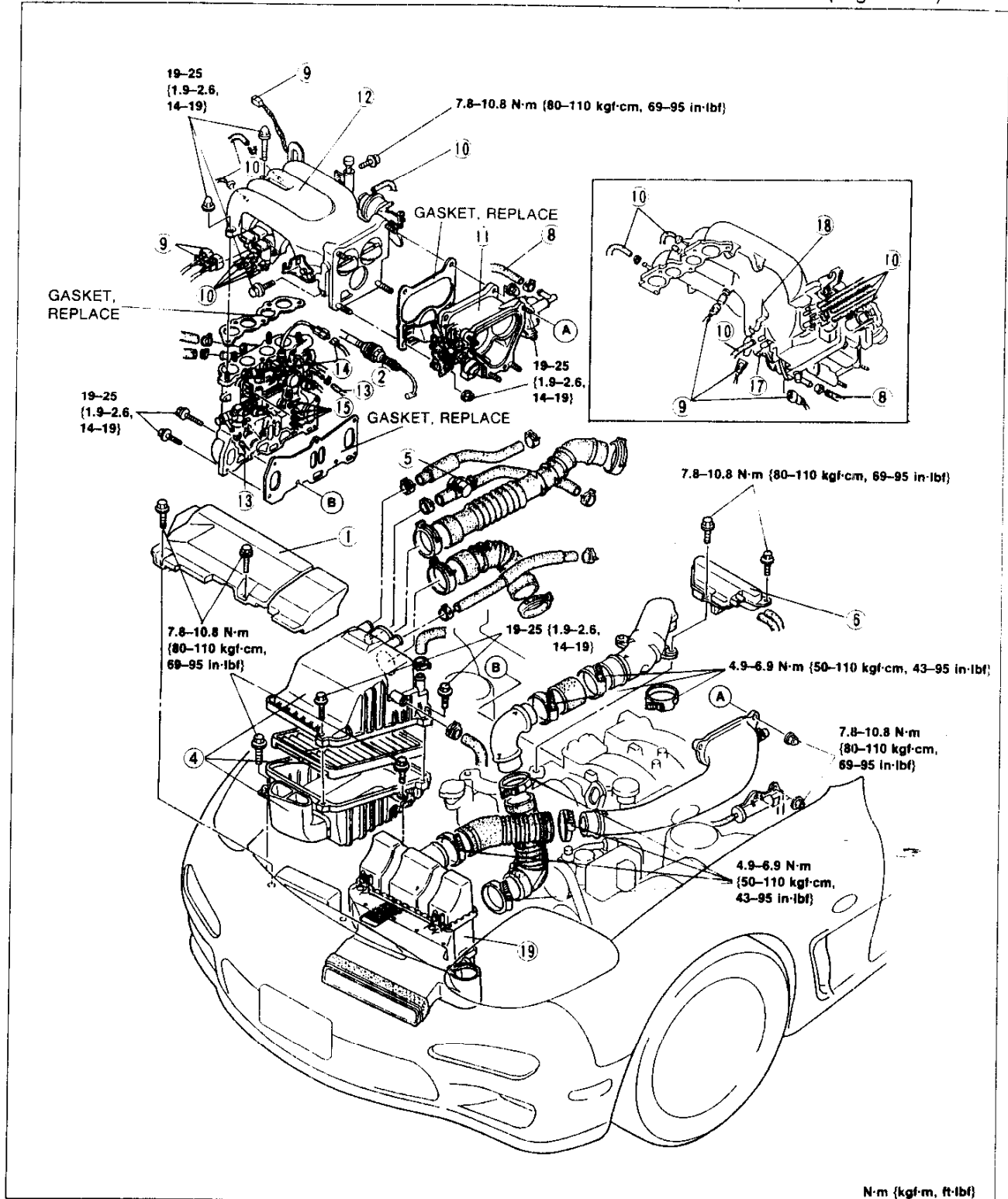

- | | |
|--|---|
| <ol style="list-style-type: none"> 1. Fresh air duct
Inspect for damage and cracks 2. Accelerator cable 3. Air intake hose
Inspect for damage 4. Air cleaner
Inspection page F-16 5. Air bypass valve
Inspection page F-77 6. Pressure chamber 7. Air intake pipe
Inspect for damage and cracks 8. Water hose 9. Connector 10. Vacuum hose | <ol style="list-style-type: none"> 11. Throttle body
Inspection page F-79 12. Extension manifold
Inspection page F-79 13. Fuel hose 14. Connector 15. Vacuum hose 16. Intake manifold
Inspection page F-79 17. Solenoid valve (ISC)
Inspection page F-83 18. Solenoid valve (AWS)
Inspection page F-83 19. Intercooler
Removal / Inspection /
Installation page F-78 |
|--|---|

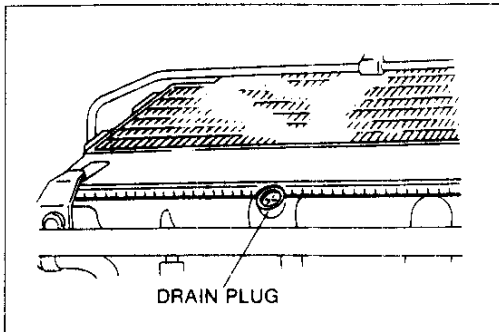

Removal Note

1. Loosen the drain plug and radiator cap and drain the coolant from radiator.
2. Remove the water hose from the throttle body.
3. After installation of the throttle body, refill the radiator. (Refer to Section E)

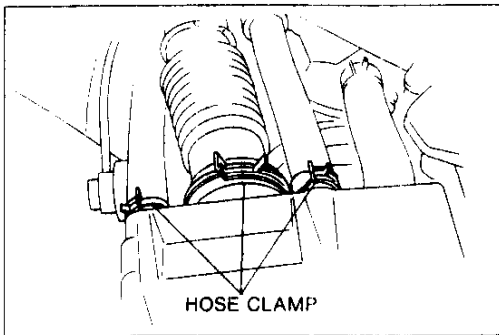

Installation Note

1. Install the air intake hose clamp and hose same place as shown in figure.

Caution

- Position the hose clamp in the original location on the hose, and squeeze it lightly with large pliers to ensure a good fit.

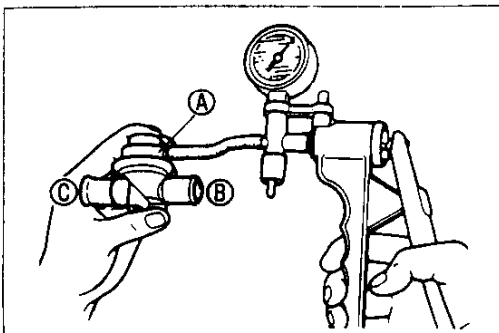

AIR BYPASS VALVE

Inspection

1. Remove the air bypass valve.
2. Connect a vacuum pump to the air bypass valve port A.
3. Check the operation of the air bypass valve.

Apply approx 14-22 kPa {100-170 mmHg, 3.9-6.7 inHg}	Air flow
Apply approx 31.3 kPa {235 mmHg, 9.2 inHg}	Fully open

F

INTAKE AIR SYSTEM

INTERCOOLER

Removal / Inspection / Installation

1. Remove in the order shown in figure.
2. Inspect the intercooler visually and repair or replace if necessary.
3. Install in the reverse order of removal, referring to **Installation Note**.

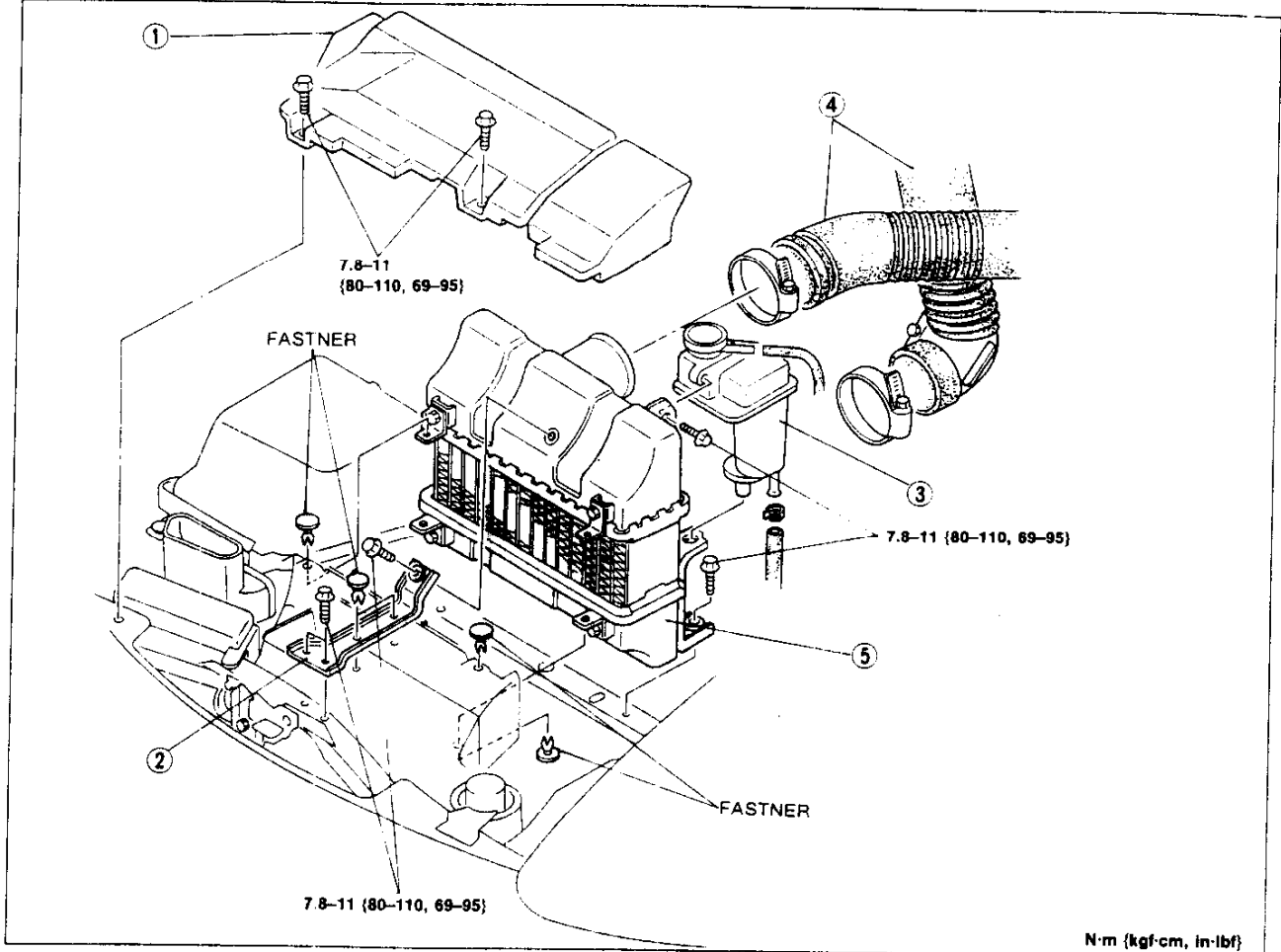

1. Fresh air duct
2. Intercooler bracket
3. Air separation tank

4. Air hose
5. Intercooler

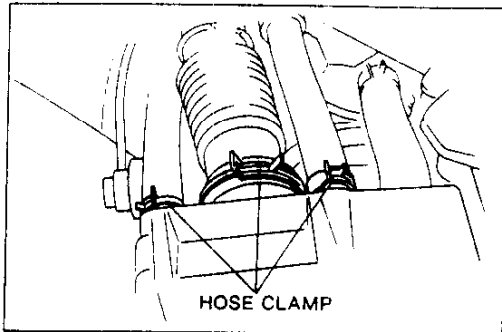

Installation Note

Install the air intake hose and hose clamp same place as show in figure.

Caution

- Position the hose clamp in the original location on the hose, and squeeze it lightly with large pliers to ensure a good fit.

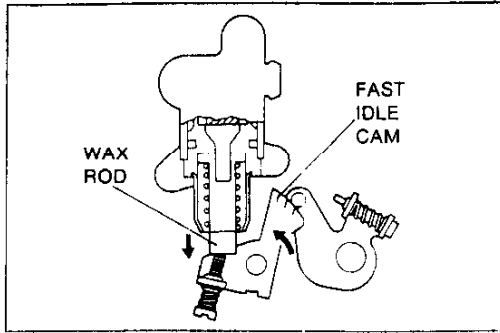

THROTTLE BODY

Inspection
Fast idle cam

1. Verify that the indicated mark on the fast idle cam is aligned with the center of the cam.
2. Warm up the engine to operating temperature and verify that the waxrod extends outward fully and the idle cam separates from the roller at 55–65°C {131–149°F}.
3. Adjust the adjust screws if necessary.

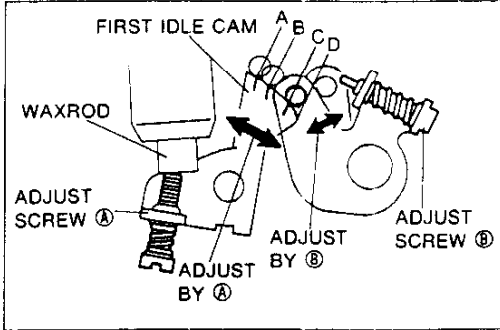

Adjustment

1. To adjust the first idle cam separates point D turn adjust screw B.
2. To adjust the first idle cam opening temperature turn adjust screw A.

Temperature	Position
-20°C {-5°F}	A
0°C {0°F}	B
25°C {77°F}	C
60°C {140°F}	D

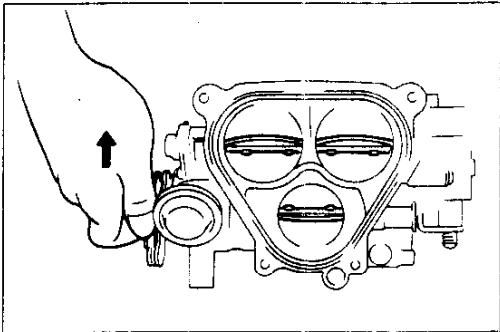

Double throttle valve

Inspection

1. Verify that the No.2 secondary throttle valve and linkage move smoothly when primary throttle valve is fully opened.
2. Replace throttle body if necessary.

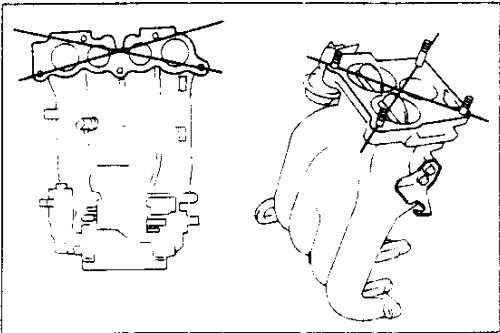

EXTENSION MANIFOLD

Inspection

1. Visually check for cracks or damage and replace it if necessary.
2. Check for distortion of extension manifold and replace if necessary.

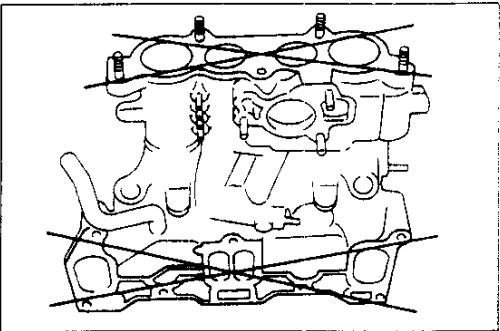

INTAKE MANIFOLD

1. Visually check for cracks or damage and replace if necessary.
2. Check for distortion of the intake manifold and replace it if necessary.

F

INTAKE AIR SYSTEM

ACCELERATOR PEDAL

Removal / Inspection / Installation

1. Remove in the order as shown in the figure.
2. Visually check the accelerator pedal and retainer for cracks or damage.
3. Install in the reverse order of removal.

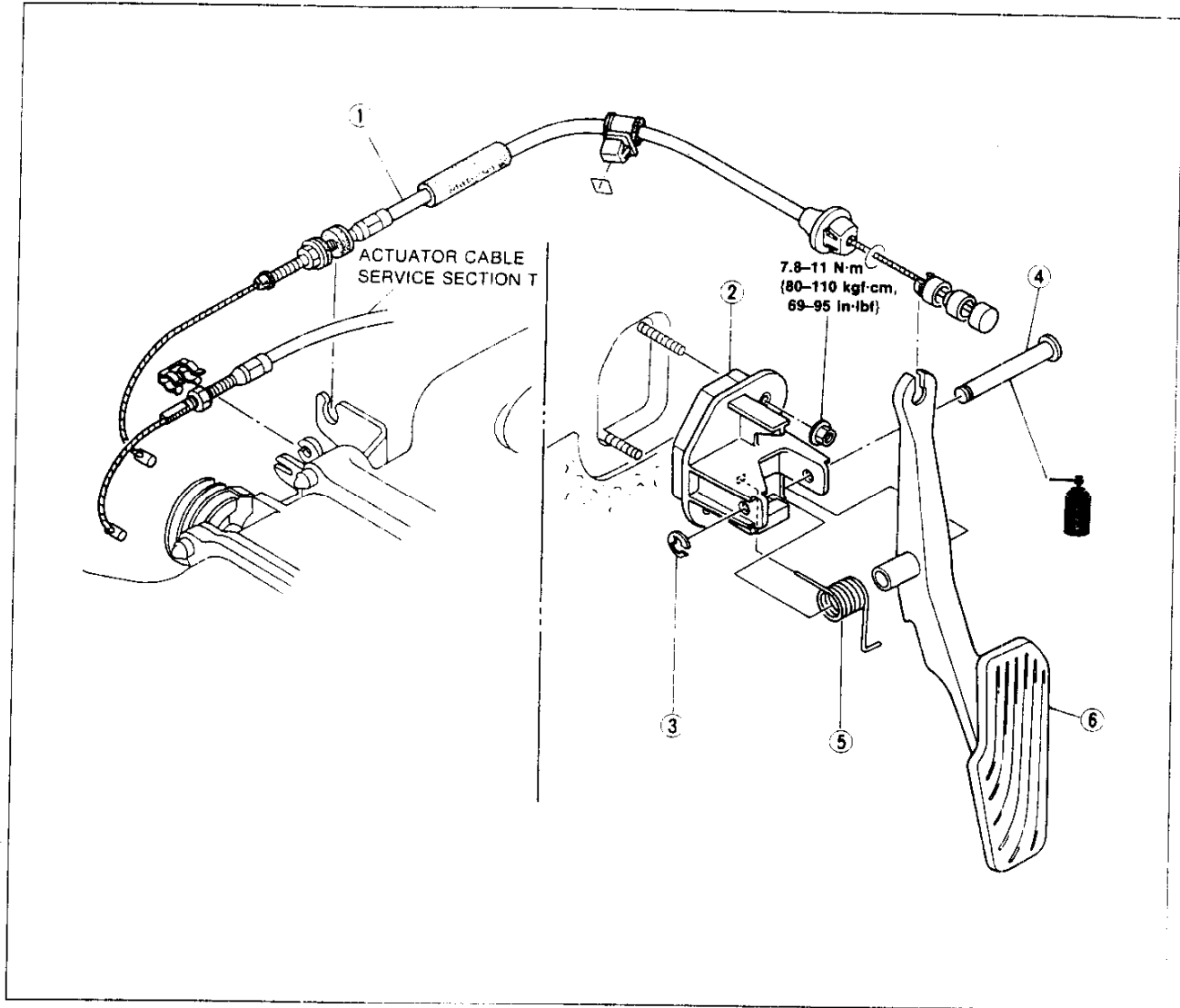

- | | |
|---|----------------------|
| 1. Accelerator cable
Inspection / Adjustment below | 4. Shaft |
| 2. Retainer | 5. Return spring |
| 3. Clip | 6. Accelerator pedal |

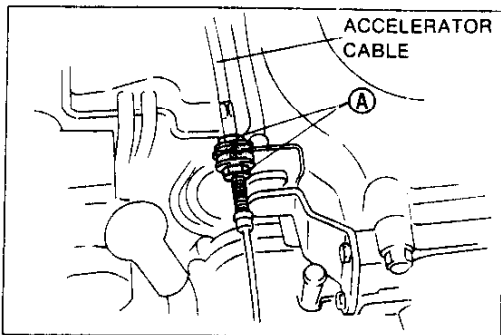

ACCELERATOR CABLE

Inspection / Adjustment

1. Warm up the engine at normal operating temperature.
2. Depress the accelerator pedal to the floor and check that the throttle valve is fully opened.
3. Inspect the play of the accelerator cable.

Play: 1-3 mm {0.04-0.12 in}

4. Loosen nuts A to adjust the play if necessary.

IDLE-SPEED CONTROL (ISC) SYSTEM

DESCRIPTION



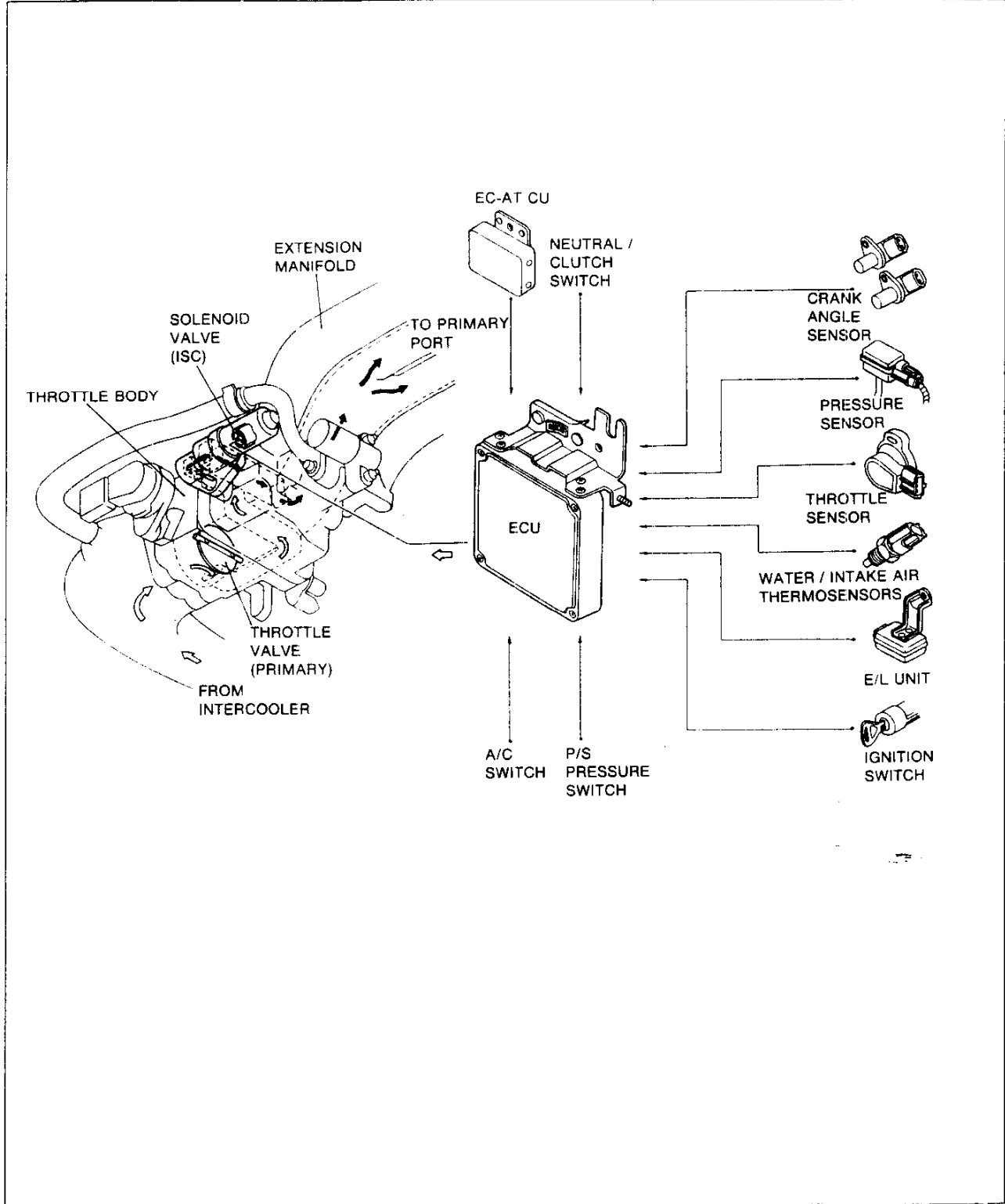

Idle speed control (ISC) system controls the bypass air amount that passes through the throttle valve, the idle-speed control system performs feedback control so that engine idle smoothly and at the target speed. The system also performs the function of the AAV (anti-afterburns valve), there by eliminating the AAV and simplifying deceleration control system.



F

IDLE-SPEED CONTROL (ISC) SYSTEM

PREPARATION SST

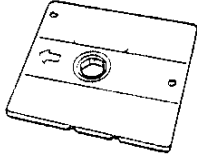
49 F088 001 DT-S1000 Base unit		For inspection of solenoid valve and relay	49 F088 002 Power unit (DC12V)		For inspection of solenoid valve
49 F088 003 Harness Power unit		For inspection of solenoid valve	49 F088 004 Interface adapter Type-1		For inspection of solenoid valve
49 F088 005 Harness Type-1		For inspection of solenoid valve	49 F088 011 System disk Type-1 (Ver 1.00)		For inspection of solenoid valve

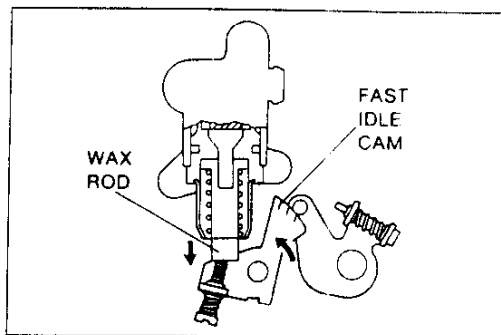

SYSTEM OPERATION

1. Warm up the engine and run it idle.
2. Verify that the fast idle cam separates.
3. Turn all electrical loads OFF.

Note

- Check the idle speed with the electric cooling fan not operating.

4. Connect a tachometer to the diagnosis connector terminal IG-
5. Verify that the idle speed is within specification.

Idle speed (Neutral or P range): 700–750 (720 \pm 30) rpm

6. Verify that the idle speed is within specification under the condition below.

Condition	Idle speed (rpm)	
	M/T	A/T
No load	700–750 (720 \pm 30)	
Electrical load ON	775–825	
Air conditioner ON	875–925	775–825

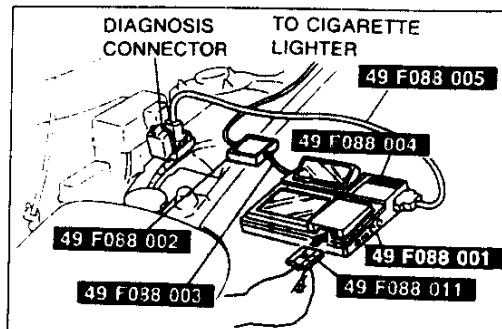
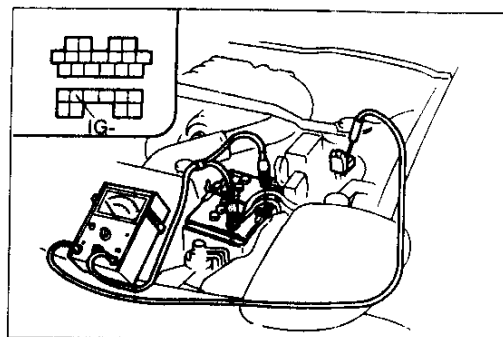

DT-S1000

1. Warm up the engine and run it idle.
2. Verify that the fast idle cam separates.
3. Connect the **SST** to the diagnosis connector.

Note

- Check the idle speed with the electric cooling fan not operating.

4. Connect a tachometer to the diagnosis connector terminal IG-

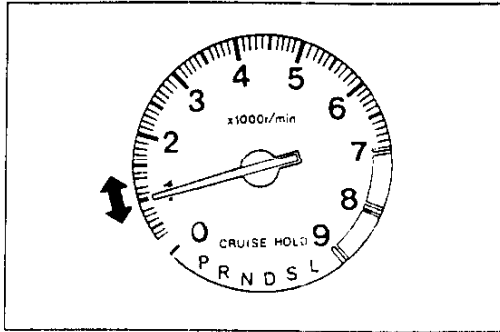

5. Verify that the idle speed is within specification.

Idle speed (Neutral or P range): 700–750 (720 ±20) rpm

6. Select simulation function and verify that the idle speed decrease and increase as the duty cycle changed.

Standard Idle duty: 32–65 %

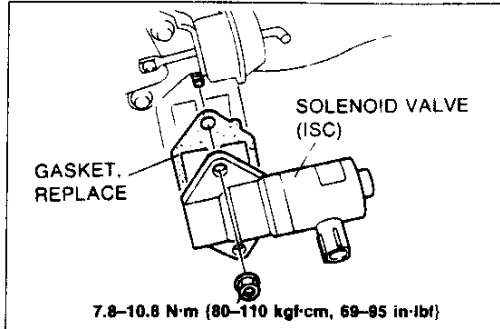

SOLENOID VALVE (IDLE SPEED CONTROL [ISC])

Removal / Installation

1. Disconnect Negative battery cable.
2. Remove the extension manifold. (Refer to Page F-76)
3. Disconnect the solenoid valve connector.
4. Remove the solenoid valve (ISC) as shown in figure.
5. Install in the reverse order of removal.

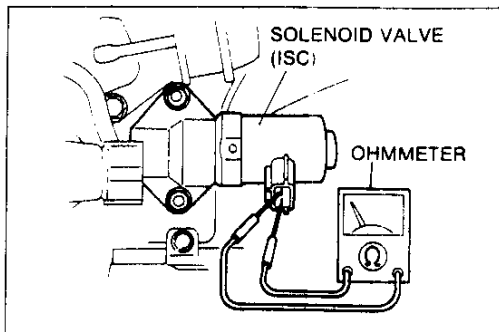

Inspection

1. Remove the solenoid valve. (Refer to above)
2. Measure the solenoid valve resistance with an ohmmeter.

Resistance: 10.7–12.3 Ω (20°C {68°F})

3. If not as specified, replace solenoid valve.

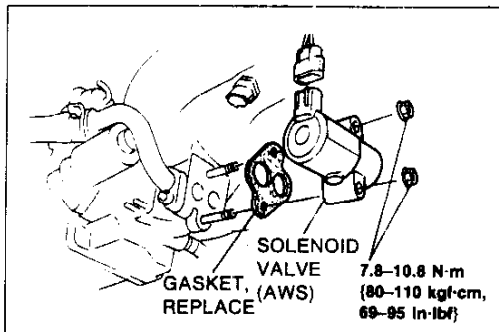

SOLENOID VALVE (ACCELERATED WARM-UP SYSTEM [AWS])

Removal / Installation

1. Disconnect Negative battery cable.
2. Remove the extension manifold. (Refer to Page F-76)
3. Disconnect the solenoid valve connector.
4. Remove the solenoid valve (AWS) as shown in figure
5. Install in the reverse order of removal.

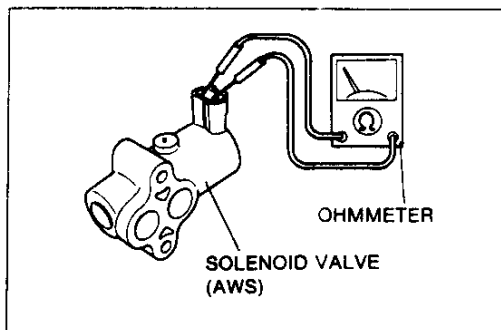

Inspection

1. Remove the solenoid valve (Refer to above F-76)
2. Measure the solenoid valve resistance with an ohmmeter

Resistance: 9.3–11.3 Ω (20°C {68°F})

3. If not as specified, replace solenoid valve.

F

SEQUENTIAL TWIN TURBOCHARGER SYSTEM

SEQUENTIAL TWIN TURBOCHARGER SYSTEM

- The sequential twin turbocharger system consists of two turbochargers (primary and secondary) fitted in line with each other. In the low-speed, light-load range, turbocharging is done only by the primary turbocharger; in the high-speed, heavy-load range, turbocharging is done by the primary and secondary turbochargers in union.
- To prevent a drop of boost pressure when the secondary turbocharger begins to operate, the secondary turbocharger is made to spin prior to its operation.
- The sequential twin turbocharger system consists of the primary and secondary turbochargers and the actuators and solenoid valves (turbo precontrol, turbo control, wastegate control, charge control, charge relief).

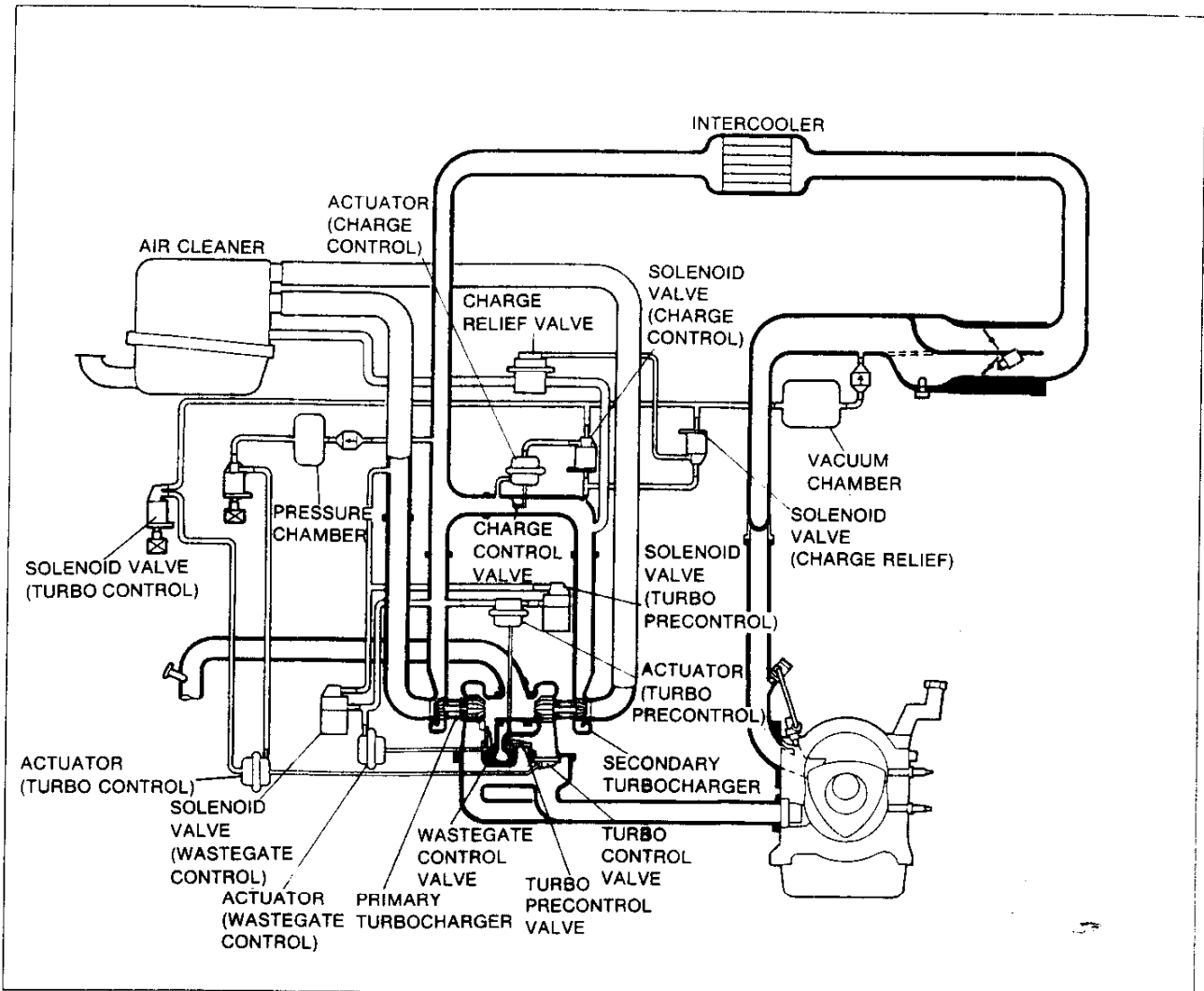







37U0FX-519

Operation

Devices	Engine speed	Low-speed		High-speed
		Light-load	Boost pressure	Heavy-load
Turbocharger	Primary		Preliminary rotation	
	Secondary	Stop		Boost
Solenoid valve	Turbo precontrol	Duty control		Duty 5% (Fully open)
	Wastegate control	Duty 95% (Fully closed)		Duty control
	Charge relief	OFF		ON
	Charge control	ON		OFF
	Turbo control	OFF		ON

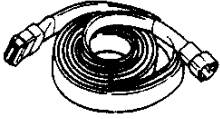
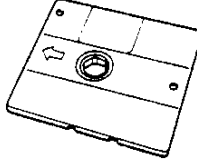
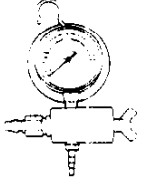
**PREPARATION
SST**

<p>49 F088 001 DT-S1000 Base unit</p> 	<p>For inspection of solenoid valve</p>	<p>49 F088 002 Power unit</p> 	<p>For inspection of solenoid valve</p>
<p>49 F088 003 Harness power unit</p> 	<p>For inspection of solenoid valve</p>	<p>49 F088 004 Interface adapter type-1</p> 	<p>For inspection of solenoid valve</p>
<p>49 F088 005 harness type-1</p> 	<p>For inspection of solenoid valve</p>	<p>49 F088 011 System disk type-1 (V1.00)</p> 	<p>For inspection of solenoid valve</p>
<p>49 F088 740 Pressure tester</p> 	<p>For inspection of turbocharger</p>	<p>49 F018 902 Adapter harness</p> 	<p>For inspection of solenoid valve</p>

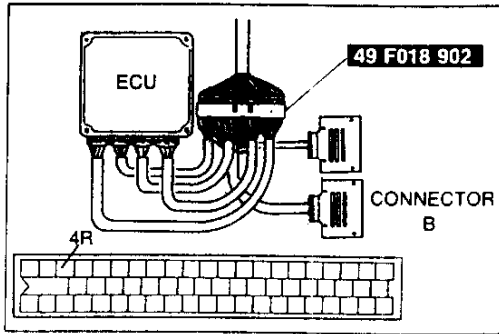

ACTUATOR (TURBO CONTROL [TCNT])

System Operation
Engine signal monitor

1. Connect the **SST** (Engine signal Monitor Adaptor Harness) to the ECU as shown.
2. Start the engine and verify that the actuator rod is moved once.
3. Run it idle.
4. Short the ECU terminal 4R and verify that the actuator rod is pulled into the actuator.
5. If the actuator rod is not moved, check the following condition below.
 - Vacuum tube
Inspect vacuum line fitting, connections and components for leaks. (Refer to page F-10)
 - Vacuum and pressure chamber
Visually check for clogging damage or crack.
 - Solenoid valve (Turbo control)
Inspection (Refer to page F-190)
 - Actuator (Turbo control)
Inspection (Refer to below)

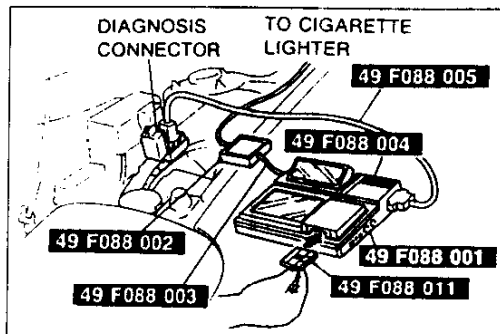
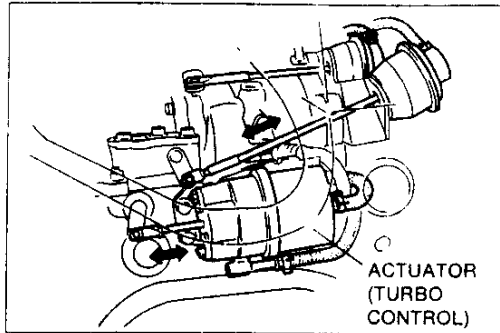

DT-S1000

1. Connect the **SSTs** (DT-S1000 and Harness) to the Diagnosis connector as shown.
2. Start the engine and run it idle.

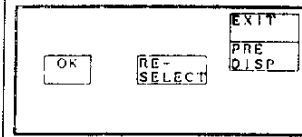
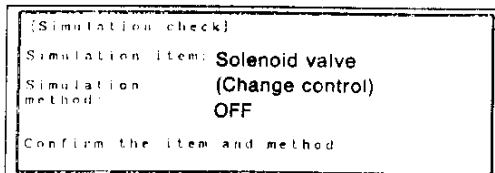

3. Select the simulation check and verify that the actuator rod is moved when solenoid valve ON and OFF.
4. If the actuator rod is not moved, check the condition above.

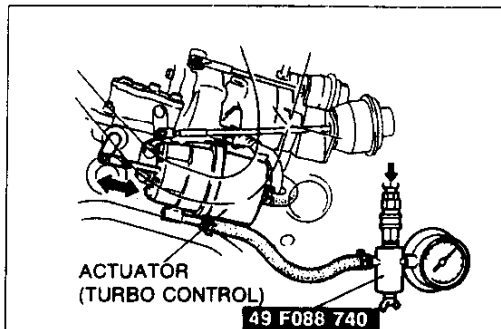

Inspection

1. Disconnect the air hose and attached it to the **SST** as shown.
2. Adjust the compressed air pressure to 49 kPa. {0.5 kg-f/cm², 7.1 psi}
3. Verify that the actuator rod is move when appying and releasing air pressure.

Caution

- Do not apply compressed air higher than 79.4 kPa {0.81 kg-f/cm², 11.5 psi}.

4. If not as specified replace the actuator. (Refer to page F-91)

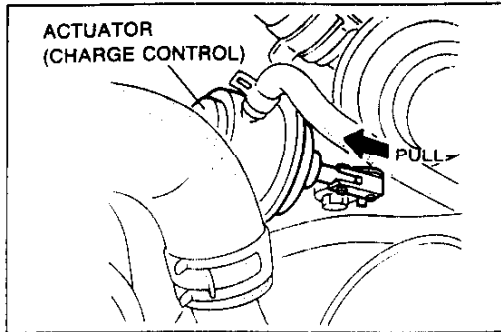

ACTUATOR (CHARGE CONTROL)

System Operation

1. Start the engine and verify that the actuator rod is pulled into the actuator.
2. If the actuator rod is not pulled, check the following condition below.
 - Vacuum tube
Inspect vacuum line fitting, connections and components for leak. (Refer to page F-10)
 - Vacuum chamber
Inspect the damage or crack.
 - Solenoid valve (Charge control)
Inspection (Refer to page F-190)
 - Actuator (Charge control)
Inspection (Refer to below)
 - Shutter valve
Inspection (Refer to below)

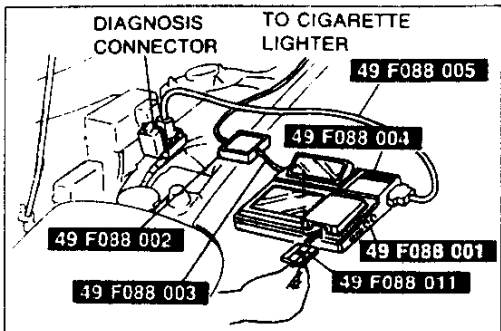

DT-S1000

1. Connect the **SSTs** (DT-S1000 and Harness) to the diagnosis connector as shown.

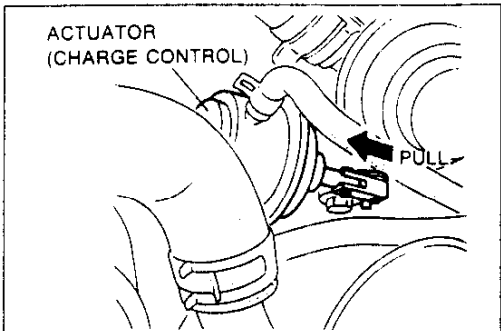

2. Select the simulation function and verify that the actuator rod is pulled when solenoid valve OFF.
3. If the actuator rod is not pulled, check the condition above.

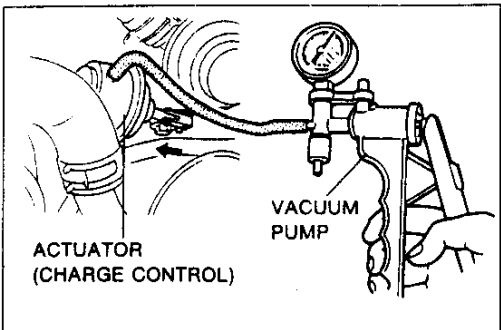

Inspection

1. Disconnect the vacuum hose from the actuator.
2. Connect a vacuum pump.
3. Verify that the actuator rod is pulled when applying vacuum more than 6.7 kPa {50 mmHg, 1.9 inHg}
4. If not as specified, replace the actuator. (Refer to page F-91)

F

SEQUENTIAL TWIN TURBOCHARGER SYSTEM

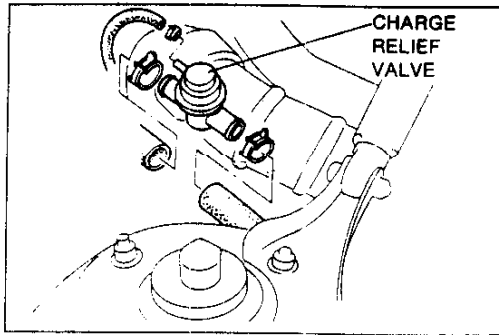

CHARGE RELIEF VALVE

Removal / Installation

1. Remove in the order shown in figure.
2. Install in the reverse order of removal.

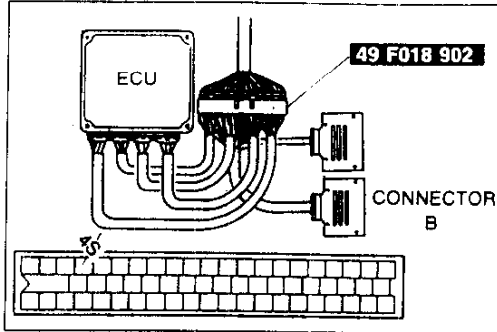

Engine Signal Monitor

System operation

1. Connect the **SST** (Engine Signal Monitor Adaptor Harness) to the ECU as shown.
2. Turn ignition switch to ON.
3. Short the ECU terminal 4S and verify that the operating sound is heard when the solenoid valve ON.
4. If no sound is heard, check the solenoid valve. (Refer to page F-190)

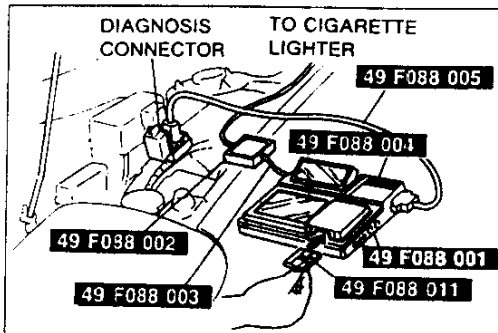

DT-S1000

1. Connect the **SSTs** (DT-S1000 and Harness) to the diagnosis connector.
2. Turn ignition switch to ON.

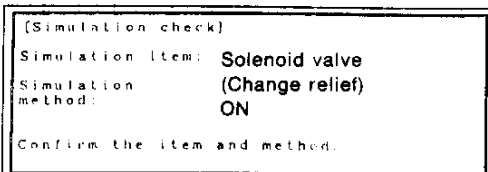

3. Select the simulation function and verify that the operating sound is heard when the solenoid valve ON and OFF.
4. If no sound is heard, check the solenoid valve. (Refer to page F-190)

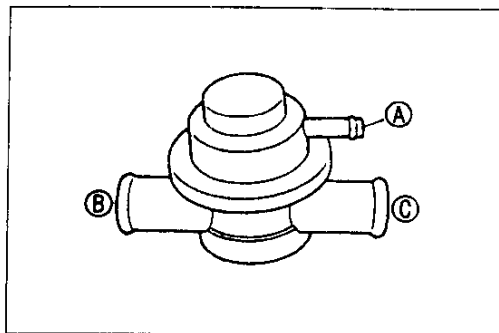
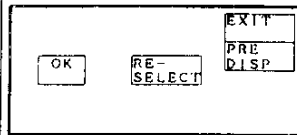

Inspection

1. Remove the charge relief valve.
2. Connect a vacuum pump to port A.
3. Apply approx 26.7 kPa {200 mmHg, 7.87 inHg} to port A and verify that air flows between B and C.
4. Replace if necessary.

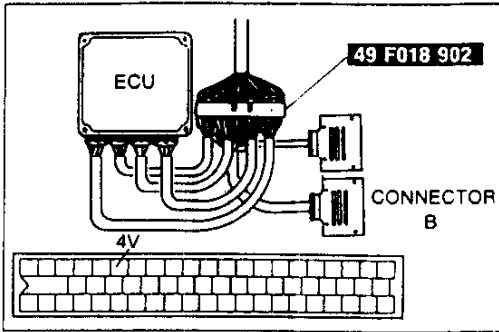

TURBOCHARGER
Actuator (Turbo precontrol)
Engine Signal Monitor
System operation

1. Connect the **SST** (Engine Signal Monitor Adaptor Harness) to the ECU.
2. Turn ignition switch to ON.
3. Short the ECU terminal 4V and verify that the operating sound is heard.
4. If no sound is heard, check the solenoid valve. (Refer to page F-93)

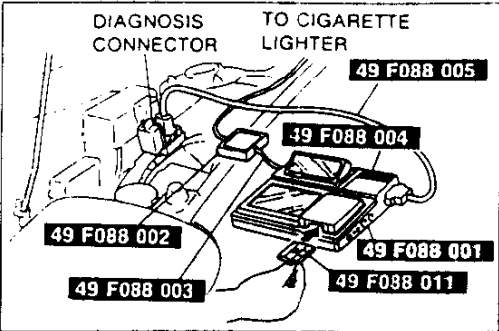

DT-S1000

1. Connect the **SSTs** (DT-S1000 and Harness) to the Diagnosis connector as shown.
2. Turn ignition switch to ON.

[Simulation check]
 Simulation item: Solenoid valve
 (Turbo precontrol)
 Simulation method: ON
 Confirm the item and method.

OK RE-SELECT EXIT PRE DISP

3. Select the simulation function and verify that the operating sound is heard when solenoid valve ON and OFF.

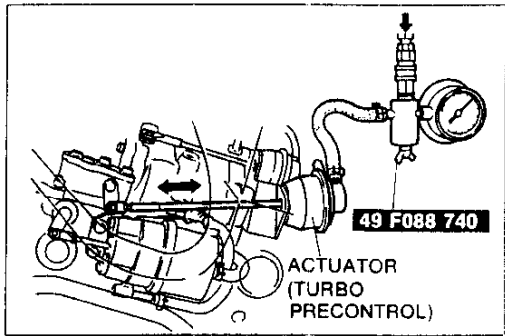

Inspection

1. Disconnect the air hoses and attached one to the **SST** and plug the other pipe as shown.
2. Verify that the actuator rod is moved when applying compressed air pressure to 69-98 kPa {0.7-1.0 kgf/cm², 10-14 psi}

Caution

● Do not apply compressed air higher than 98 kPa {1.0 kgf/cm², 14 psi}

3. Replace turbocharger, if necessary. (Refer to page F-91)

F

SEQUENTIAL TWIN TURBOCHARGER SYSTEM

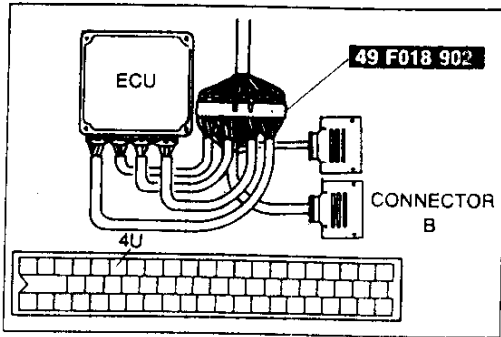

Actuator (wastegate control) Engine Signal Monitor System Operation

1. Connect the **SSTs** (Engine Signal Monitor and Adaptor Harness) to the ECU.
2. Turn ignition switch to ON.
3. Short the ECU terminal 4U and verify that the operating sound is heard.
4. If no sound is heard check the solenoid valve (Refer to page F-93)

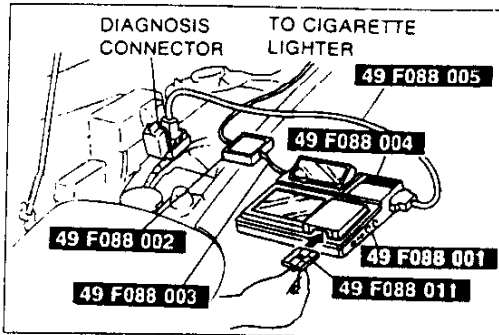

DT-S1000

1. Connect the **SSTs** (DT-S1000 and Harness) to the Diagnosis connector as shown.
2. Turn ignition switch to ON.
3. Select the simulation function and verify that the operating sound is heard when solenoid valve ON and OFF.

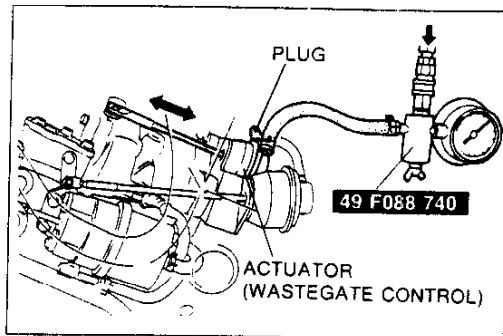

Inspection

1. Disconnect the air hoses and attached one to the **SST** and plug the other pipe as shown.
2. Verify that the actuator rod is moved when applying pressed air pressure to 69-98 kPa {0.7-1.0 kgf/cm² 10-14 psi}

Caution

- Do not apply compressed air higher than 98 kPa {1.0 kgf/cm² 14 psi}

3. Replace turbocharger, if necessary. (Refer to page F-91)

Removal / Installation

Caution

- Be careful of following points after turbocharger removal.
- Do not hold the actuator rod or hose when carrying the turbocharger.
- Do not damage the actuator and actuator rod.
- Cover the turbocharger compressor air inlet / outlet, turbine exhaust inlet / outlet and oil passage to prevent dirt or other material from entering
- Set the turbocharger down with turbine shaft horizontal.
- Use the specified new studs when installing the turbocharger.

1. Disconnect the negative battery cable.
2. Lift up the vehicle.
3. Drain the engine coolant.
4. Remove in the order shown in the figure.
5. Install in the reverse order of removal, referring to **Installation Note**.

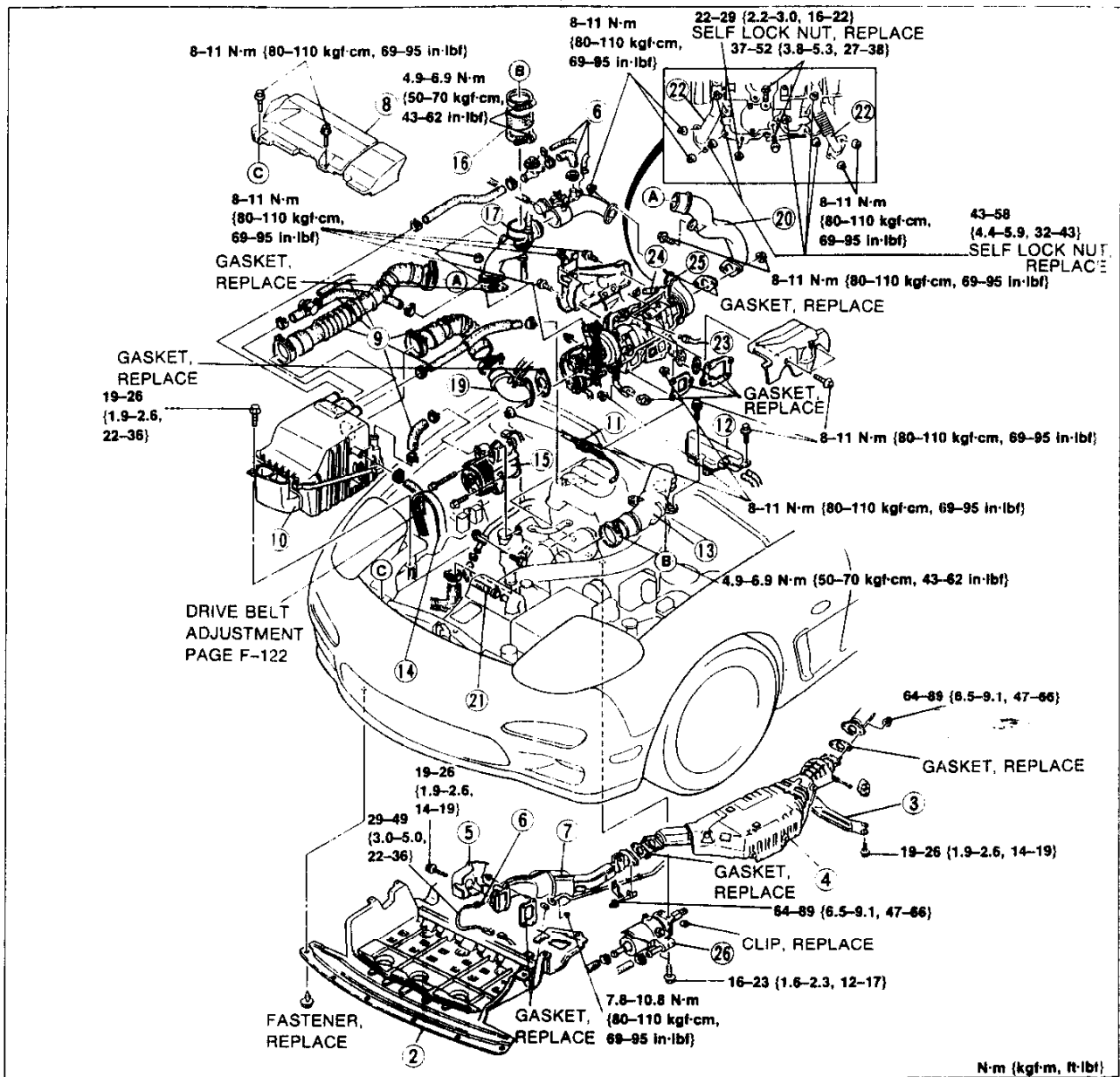

F

SEQUENTIAL TWIN TURBOCHARGER SYSTEM

- | | |
|--|---|
| 1. Negative battery cable | 16. Air hose |
| 2. Under cover | 17. Air pipe |
| 3. Bracket | 18. Charge control valve assembly
Inspection page F-87 |
| 4. Main converter assembly | 19. Air intake pipe (Secondary) |
| 5. Insulator | 20. Air intake pipe (Primary) |
| 6. Oxygen sensor | 21. Water hose |
| 7. Front converter | 22. Oil return pipes |
| 8. Fresh air duct | 23. Oil pipe |
| 9. Air hoses | 24. Water hose |
| 10. Air cleaner | 25. Turbocharger
Inspection below |
| 11. Accelerator cable
Removal / Installation page F-80
Inspection / Adjustment page F-80 | 26. Actuator (Turbo control)
Inspection page F-86 |
| 12. Pressure chamber | |
| 13. Air pipe | |
| 14. Drive belt | |
| 15. Air pump | |

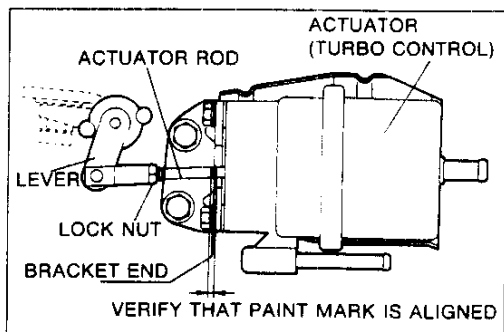

Installation Note

1. Verify that the paint mark on the actuator rod is aligned with actuator bracket end.
2. If the mark is not aligned, adjust the actuator rod length

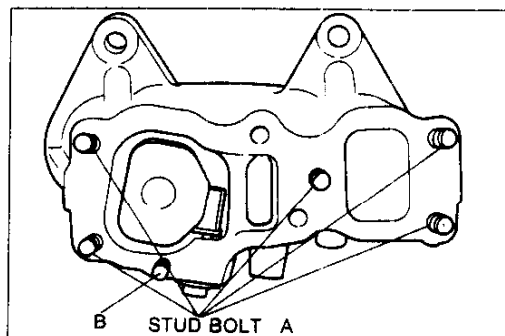

3. Check the stud bolt tightening torque before installing turbocharger.

Tightening torque

- A: 16-24 N·m {1.6-2.4 kgf·m, 12-17 ft·lbf}**
B: 8-12 N·m {0.8-1.2 kgf·m, 5.8-8.7 ft·lbf}

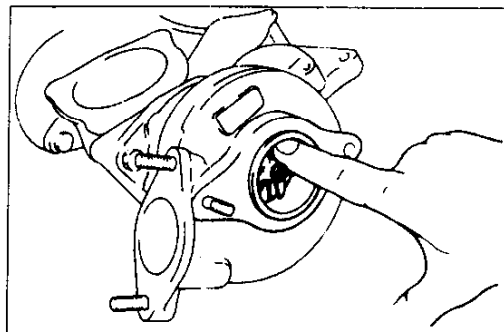

Inspection

1. Be sure the engine is cool
2. Remove the turbocharger.
3. Check that the compressor wheel assembly turns smoothly.
4. If there is excessive drag or noise, replace the turbocharger.

SOLENOID VALVE (TURBO PRECONTROL, WASTEGASTE CONTROL)

Removal / Installation

1. Remove in the order shown in figure.
2. Install in the reverse order of removal.

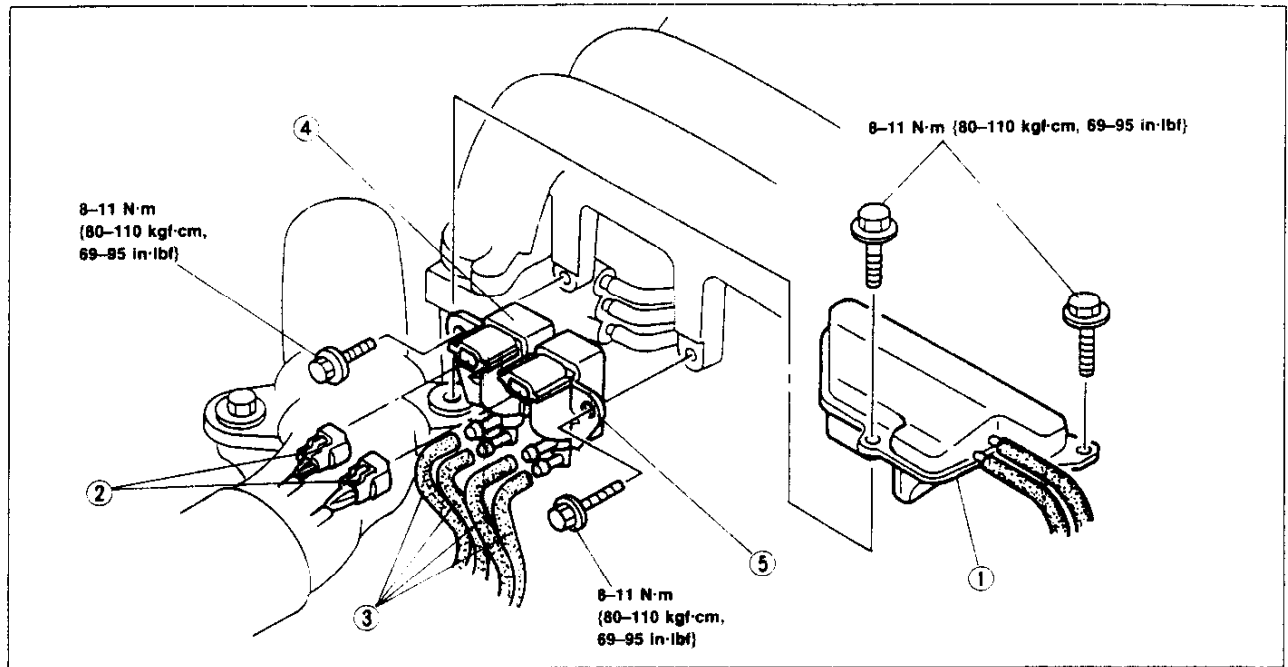

- | | |
|---|---|
| <ol style="list-style-type: none"> 1. Pressure chamber 2. Connectors 3. Vacuum hoses | <ol style="list-style-type: none"> 4. Solenoid valve. (Turbo precontrol)
Inspection below 5. Solenoid valve. (Wastegate control)
Inspection below |
|---|---|

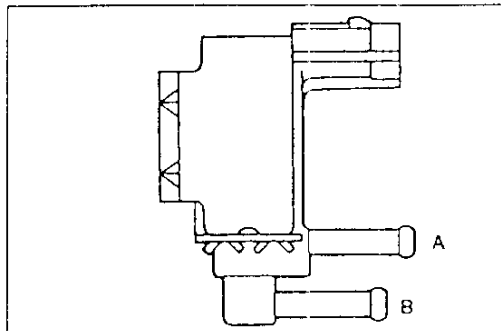

Inspection

1. Remove the solenoid valve.
2. Blow through the solenoid valve from hose A and check that air does not flow from B to A.

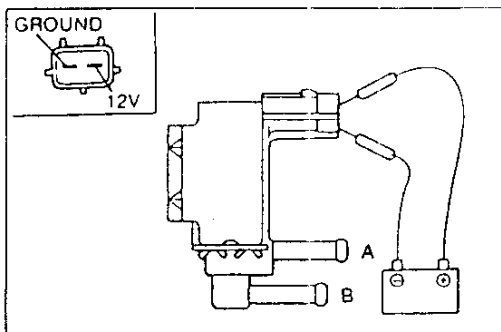

3. Apply battery voltage to solenoid valve and check that air does flow through the solenoid valve from A to B.
4. If not as specified measure the resistance.

Resistance: 29-33 Ω {20°C [68°F]}

F

FUEL SYSTEM





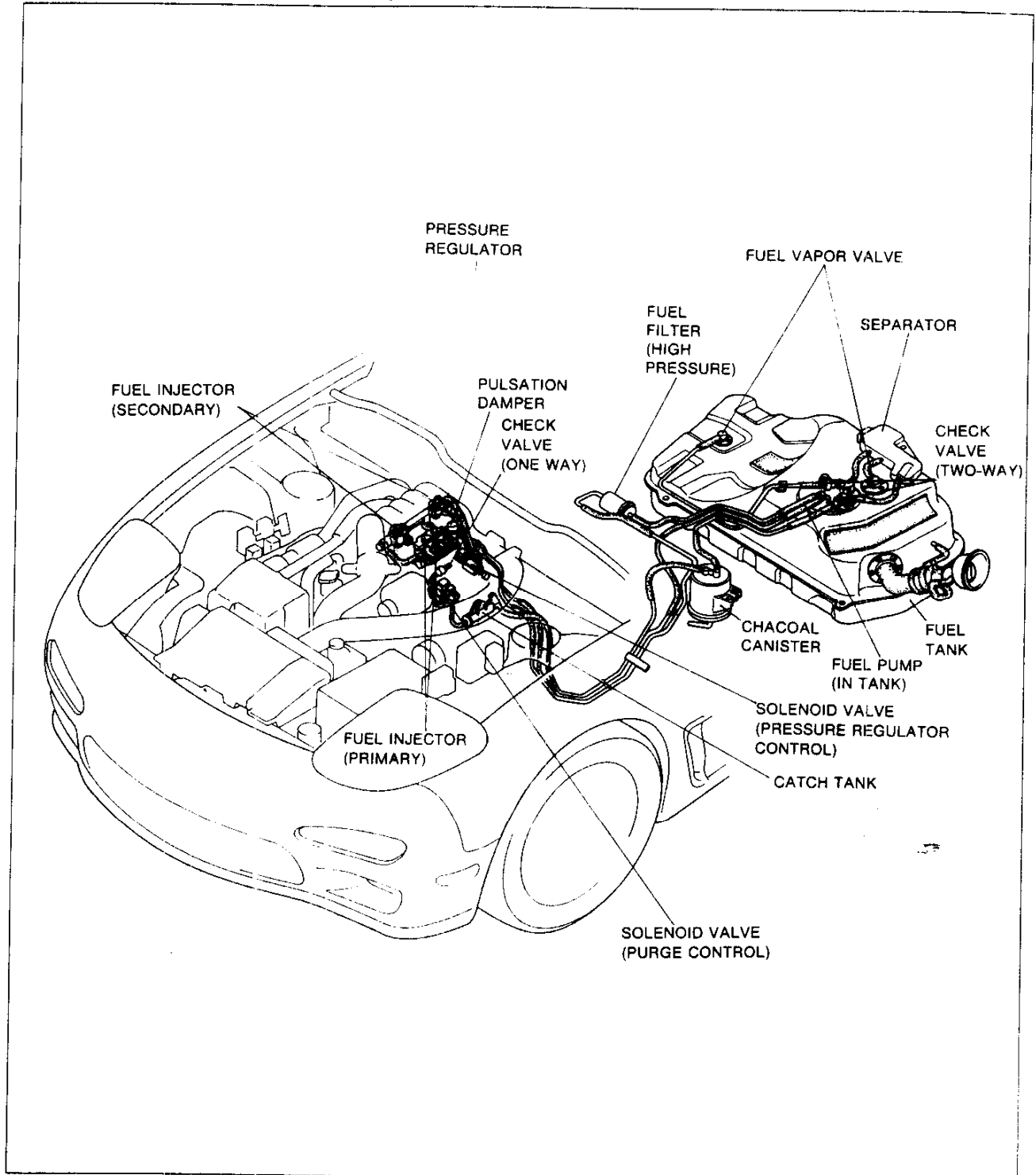

FUEL SYSTEM DESCRIPTION

This system supplies the necessary fuel at constant pressure to the injectors. Fuel is metered and injected into intake manifold and intake port according to the injection control signals from the ECU. (Engine Control Unit)

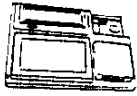
This system consists of fuel pump, fuel filters, pressure regulator, pulsation damper, solenoid valve (Pressure regulator control), and injectors.

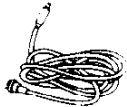

PREPARATION
SST

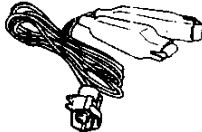
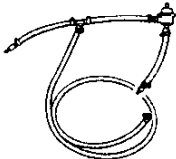
<p>49 F088 001 DT-S1000 Base unit</p> 	<p>For inspection of relay</p>	<p>49 F088 002 Power unit DC-12V</p> 	<p>For inspection of relay</p>
<p>49 F088 003 Power unit Harness</p> 	<p>For inspection of relay</p>	<p>49 F088 004 Interface Adaptor Type-1</p> 	<p>For inspection of relay</p>
<p>49 F088 005 Harness Type-1</p> 	<p>For inspection of relay</p>	<p>49 F088 011 System disk Type-1 (Ver 1.00)</p> 	<p>For inspection of relay</p>
<p>49 L018 901 Injector checker</p> 	<p>For inspection of injector</p>	<p>49 F013 102 Injector checker Hose</p> 	<p>For inspection of injector</p>

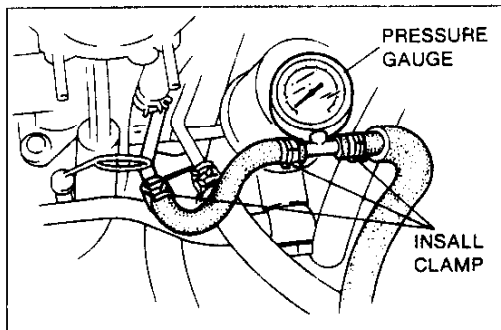
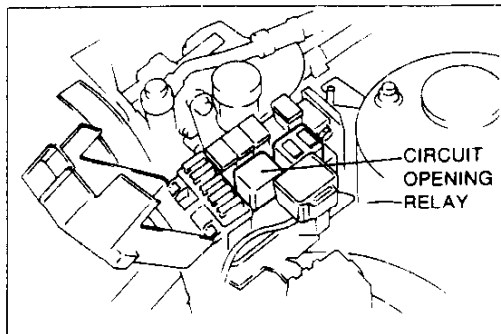

PRECAUTION

Fuel Pressure Release and Servicing Fuel System

Fuel in the fuel system remains under high pressure even when the engine is not running.

Before disconnecting any fuel line, release the fuel pressure from the fuel system as described to reduce the possibility of injury or fire.

1. Start the engine.
2. Remove the circuit opening relay.
3. After the engine stalls, turn OFF the ignition switch.
4. Install the circuit opening relay.

Use a rag as protection from fuel spray when disconnecting the hoses.

Plug the hoses after removal.

When inspecting the fuel system, use a fuel pressure gauge.

Caution

- Install hose clamps to secure the fuel pressure gauge to the fuel pipe and the fuel main hose to prevent fuel leakage.

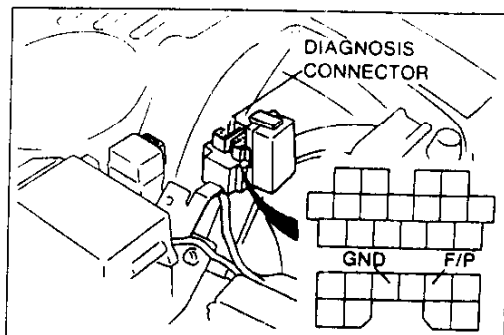
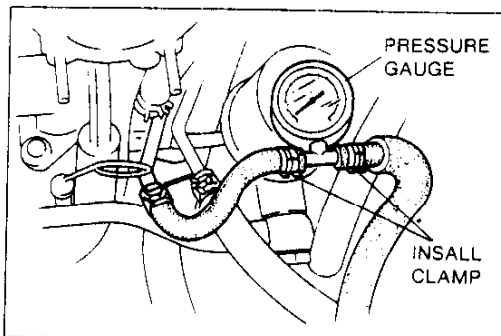
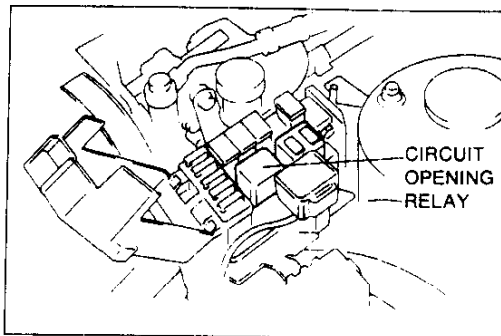
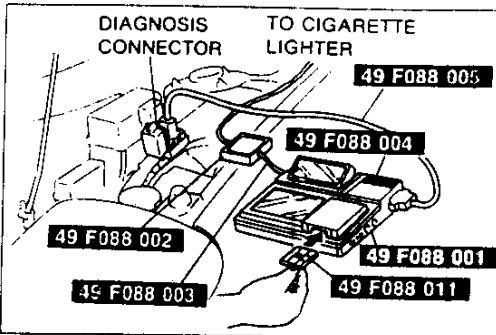
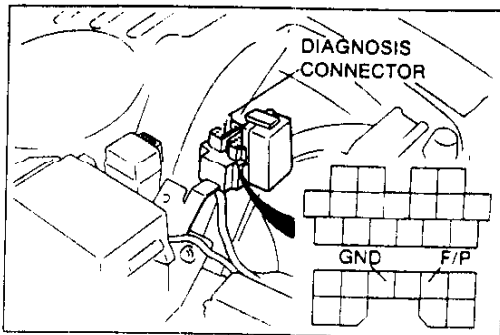

Priming Fuel System

After releasing the fuel pressure for repairs or inspection, the system must be primed to avoid excessive cranking when first starting the engine. Follow the steps below.

1. Connect the diagnosis connector terminals **F/P** and **GND** with a jumper wire.
2. Turn the ignition switch ON for Approximately 10 (ten) seconds and check for fuel leaks.
3. Turn the ignition switch OFF and remove the jumper wire.

SYSTEM OPERATION

1. Connect the **SSTs** (DT-S1000 and Harness) to the diagnosis connector.
2. Start the engine and run it idle.
3. Select the simulation check and verify that the engine speed is dropped when injector stopped.

Fuel Pressure Hold Inspection

Warning

- Before performing the following operation, release the fuel pressure from the fuel system to reduce the possibility of injury or fire. (Refer to page F-96)

1. Disconnect the negative battery terminal.
2. Install a fuel pressure gauge as shown.
3. Connect the negative battery terminal.
4. Connect the diagnosis connector terminals **F/P** and **GND** with a jumper wire.
5. Turn the ignition switch ON for **10 seconds** to operate the fuel pump.
6. Turn the ignition switch OFF and disconnect the jumper wire.
7. Observe the fuel pressure **5 minutes**.

Fuel pressure:

More than 150 kPa {1.5 kgf/cm², 21 psi}

8. If not as specified, perform the following inspections.
 - Fuel pump hold pressure. (Refer to page F-100)
 - Pressure regulator fuel line pressure. (Refer to page F-104)
 - Injector fuel leakage. (Refer to page F-107)

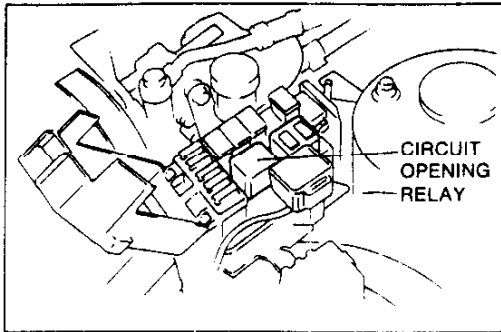

Fuel Line Pressure Inspection

Warning

- Before performing the following operation, release the fuel pressure from the fuel system to reduce the possibility of injury fire. (Refer to page F-95)

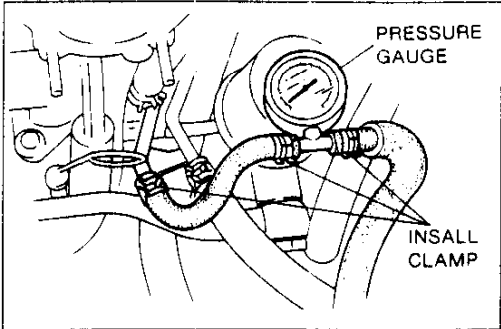

1. Disconnect the negative battery cable.
2. Install a fuel pressure gauge as shown in the figure.
3. Connect the negative battery cable.

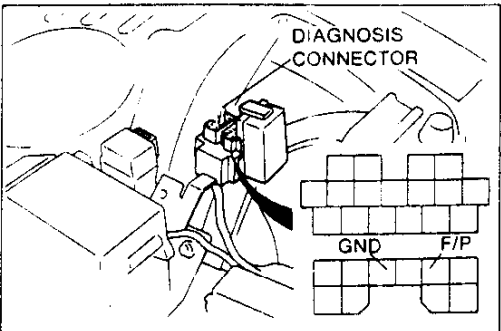

4. Connect diagnosis connector terminals **F/P** and **GND** with a jumper wire.
5. Turn the ignition switch ON.
6. Measure the fuel line pressure.

Fuel line pressure:

250-260 kPa {2.5-2.7 kg/cm², 36-38 psi}

- Pressure low - Measure fuel pump maximum pressure. (Refer to page F-101) If as specified, the fuel line or fuel filter might be clogged or restricted.
- Pressure high - Replace the pressure regulator. (Refer to page F-105)

F

FUEL SYSTEM

FUEL TANK

Removal / Inspection / Installation

Warning

- Before performing the following operation, release the fuel pressure from the fuel system to reduce the possibility of injury or fire. (Refer to page F-95.)
- When removing the fuel tank, keep sparks, cigarettes, and open flames away from it.
- Before repairing the fuel tank, clean it thoroughly with steam to remove all explosive gas.

1. Remove in the order shown in the figure.
2. Inspect the fuel tank components visually and repair or replace if necessary.
3. Install in the reverse order of removal, referring to **Installation Note**.

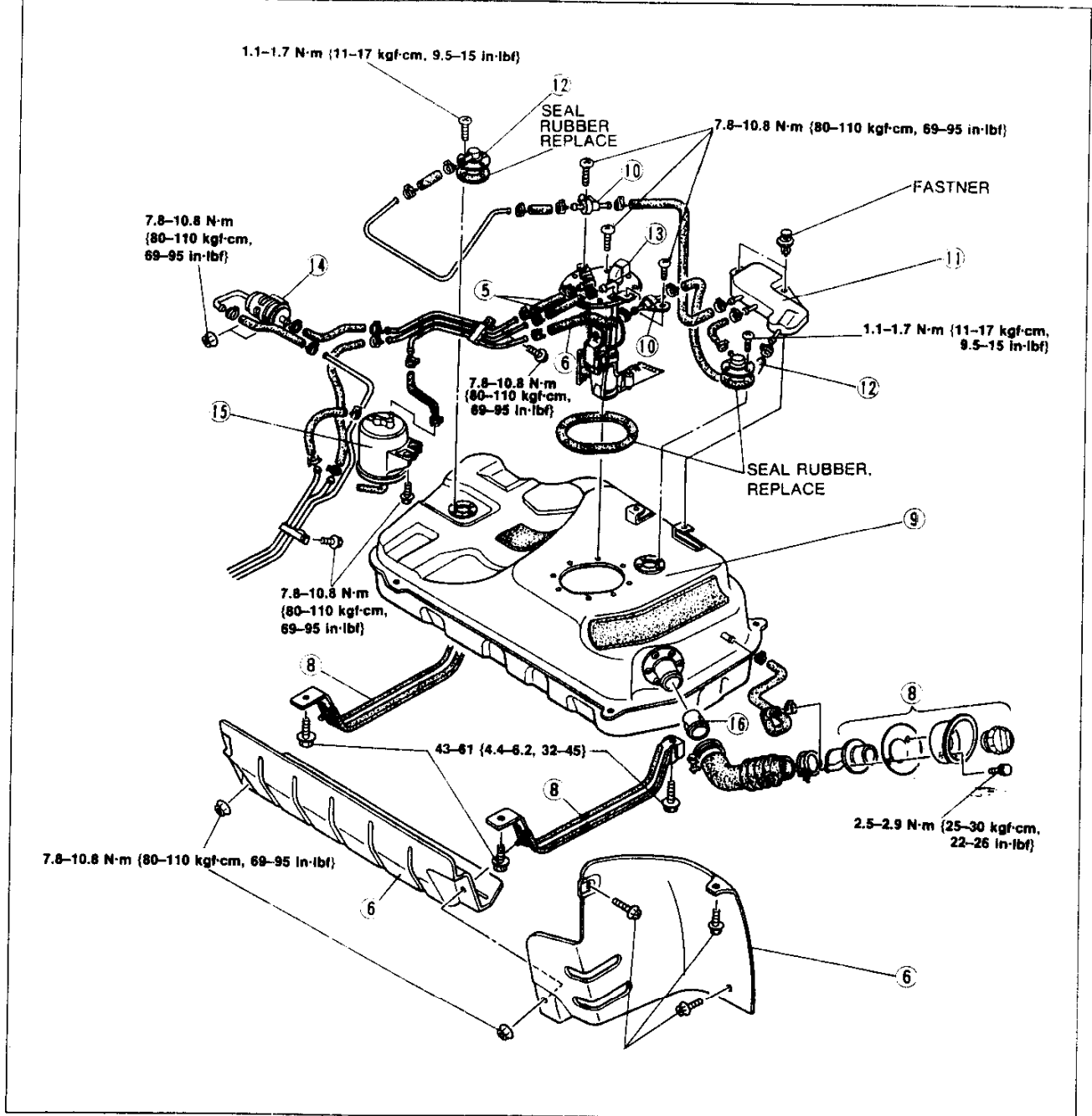

Note

- Drain the fuel from the fuel tank before removing the fuel tank.

- | | |
|-----------------------------------|---|
| 1. Battery cable | 8. Check valve |
| 2. Fuel hoses | Inspection page F-132 |
| Installation Note page F-99 | 9. Separator |
| 3. Evaporative hoses | Inspect for cracks and corrosion |
| Installation Note page F-99 | 10. Fuel vapor valve |
| 4. Under cover | Inspection page F-132 |
| 5. Fuel filler pipe | 11. Fuel pump |
| 6. Fuel tank strap | Inspection |
| 7. Fuel tank | Removal / Installation |
| Inspect for cracks and corrosion | Assembly / Disassembly page F-102 |
| | 12. Nonreturn valve |

Installation Note

1. Push the ends of the main fuel hose, fuel return hose, and evaporative hoses onto the fuel tank fittings **at least 25 mm {1.0 in.}**
2. Push the fuel filter hose onto the fuel tank pipe and filter pipe **at least 35 mm {1.4 in.}**
3. Push the evaporative hoses onto the fuel vapor valve **at least 20 mm {0.8 in.}**
4. Push the evaporative hoses onto the check valve **at least 17 mm {0.7 in.}**
5. Connect the fuel filler hose and breather hose onto the fuel tank as shown in the figure.

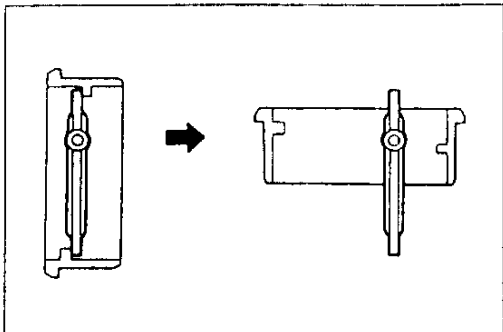
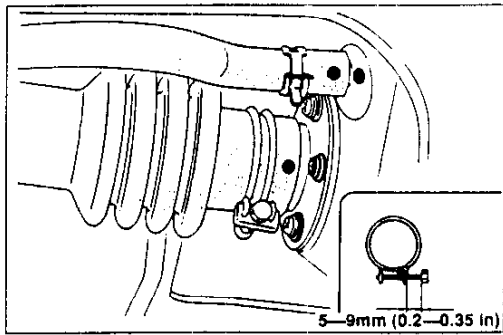

Nonreturn Valve

Verify that the nonreturn valve operates under its own weight as shown in the figure.

F

FUEL SYSTEM

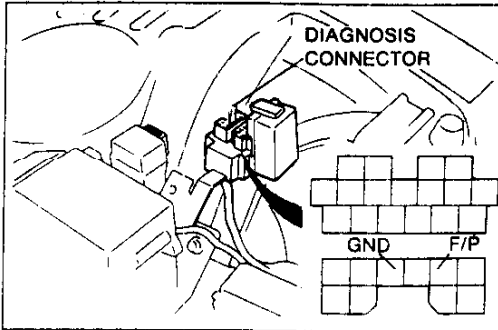

FUEL PUMP

Inspection

Fuel pump operation

1. Connect the diagnosis connector terminals **F/P** and **GND** with a jumper wire.
2. Remove the fuel filler cap.
3. Turn the ignition switch ON.
4. Listen for operational sound of the fuel pump at the filler inlet.
5. Install the fuel filler cap.
6. If no sound was heard, measure the voltage between the fuel pump connector wire W/R to ground.

Voltage: Battery voltage

7. If not correct, check the circuit opening relay and its circuits. (Refer to page F-110.)
8. If the voltage is normal, check for continuity between fuel pump connector A and B.
9. If there is continuity, replace the fuel pump.
10. If there is no continuity, repair the ground circuit.

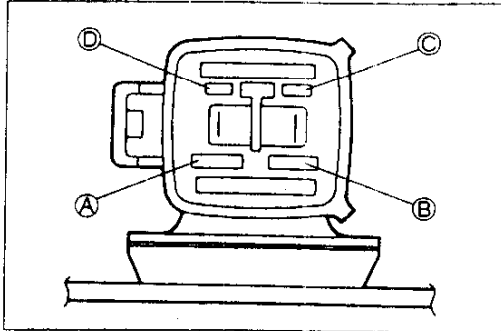

Hold pressure

Perform the inspection if the fuel pressure hold inspection is not as specified.

Warning

- **Before performing the following operation, release the fuel pressure from the fuel system to reduce the possibility of injury or fire. (Refer to page F-96.)**

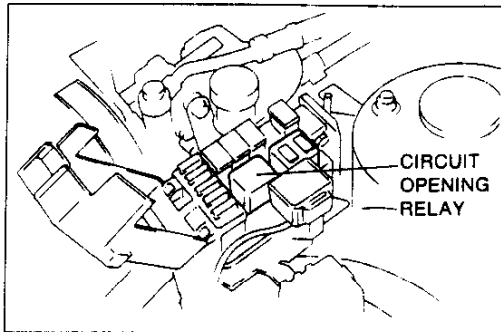

1. Disconnect the negative battery terminal.
2. Connect a fuel pressure gauge to the fuel main pipe and plug the outlet of the fuel pressure gauge as shown. (Install clamps as shown.)
3. Connect the negative battery terminal.

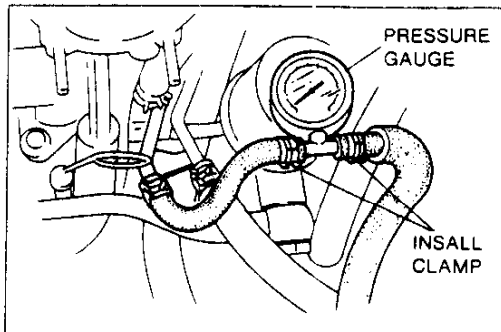

4. Connect diagnosis connector terminals **F/P** and **GND** with a jumper wire.
5. Turn the ignition switch ON and measure the fuel pressure.

Fuel pressure:

490-740 kPa {5.0-7.5 kgf/cm², 71-106 psi}

6. Turn the ignition switch OFF and disconnect the jumper wire.
7. If not as specified, replace the fuel pump.

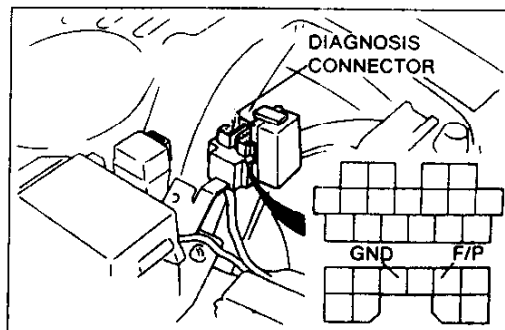

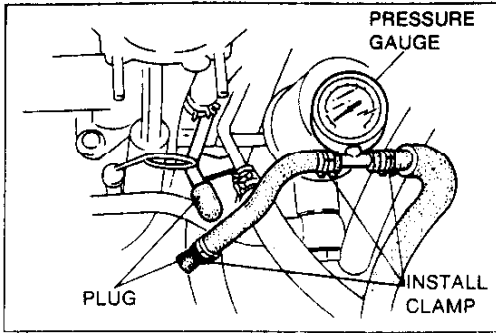

Fuel pump maximum pressure

Warning

● Before performing the following operation, release the fuel pressure from the fuel system to reduce the possibility of injury or fire. (Refer to page F-96.)

1. Disconnect the negative battery terminal.
2. Connect a fuel pressure gauge to the fuel main pipe and plug the outlet of the gauge as shown. (Install clamps as shown.)
3. Connect the negative battery terminal.
4. Connect diagnosis connector terminals **F/P** and **GND** with a jumper wire.
5. Turn the ignition switch ON to operate the fuel pump.
6. Measure the pump maximum pressure.

Fuel pump maximum pressure:

490-740 kPa {5.0-7.5 kgf/cm², 71-107 psi}

7. Turn the ignition switch OFF and disconnect the jumper wire.
8. If not as specified, replace the fuel pump.

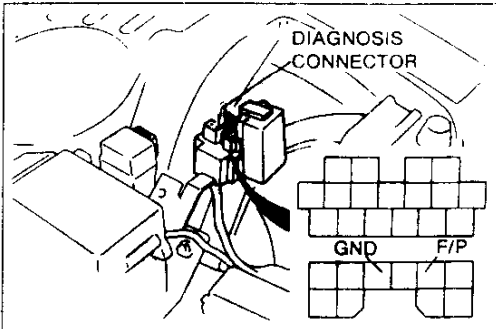

Continuity Inspection

1. Remove the luggage room carpet.
2. Remove the acoustic wave guide assembly. (if equipped)
3. Disconnect the fuel pump connector.
4. Check for continuity between the fuel pump connector A and B.
5. If there is none, replace the fuel pump.

Remove / Installation
(Refer to page F-98)

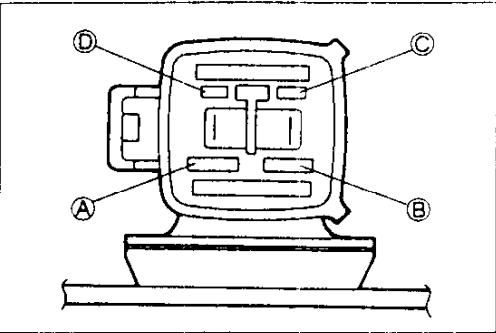
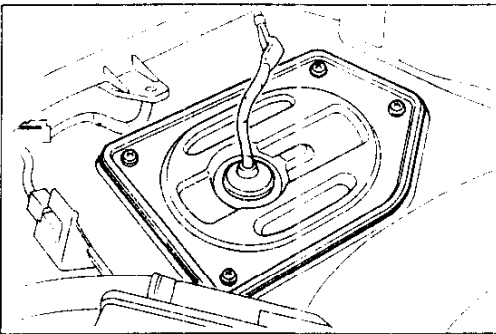

FUEL FILTER

Replacement

Warning

- Always work away from sparks and open flames.

High-pressure side

The fuel filter must be replaced at the intervals outlined in the maintenance schedule.

1. Before removing the fuel filter, release the fuel pressure from the fuel system.
2. Remove in the order shown in figure.
3. Install in the reverse order of removal.

Note

- When installing the filter, push the fuel hoses fully onto the fuel filter.

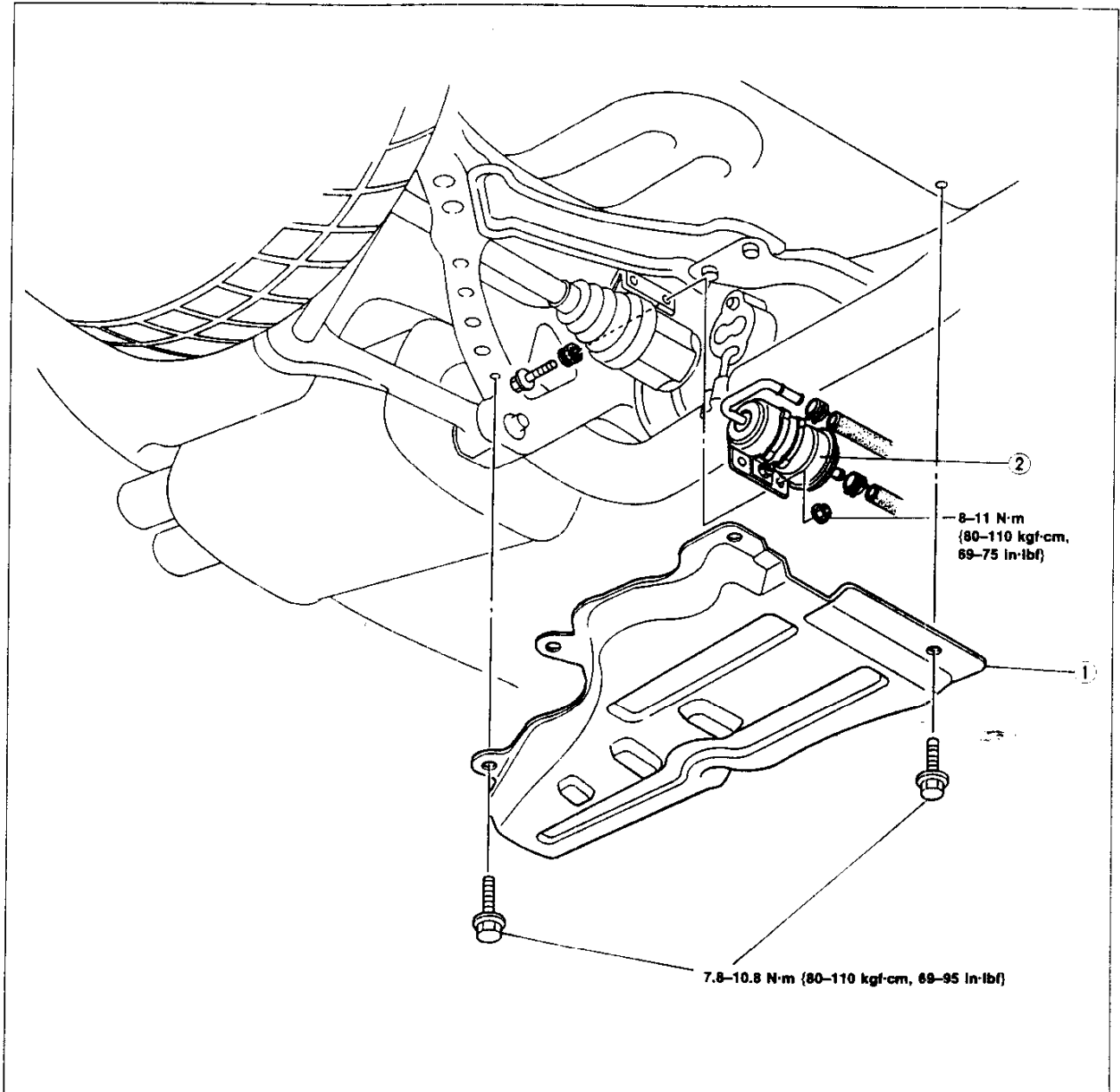

1. Under cover

2. Fuel filter (High-pressure side)

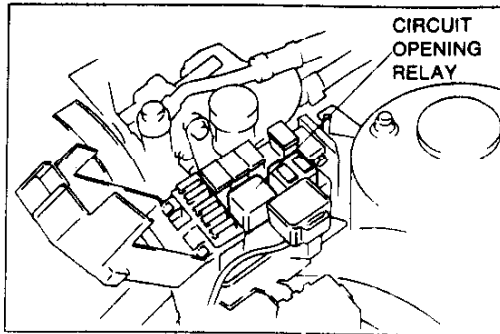
**PRESSURE REGULATOR****Inspection****Fuel line pressure****Warning**

- Before performing the following operation, release the fuel pressure from the fuel system to reduce the possibility of injury or fire. (Refer to page F-96.)

1. Disconnect the negative battery terminal.
2. Connect a fuel pressure gauge between the fuel filter and the fuel main hose. (Install clamps as shown.)
3. Connect the negative battery terminal.
4. Start the engine and run at idle.
5. Measure the fuel line pressure.

Fuel line pressure:

190–220 kPa {1.9–2.3 kgf/cm², 28–32 psi}

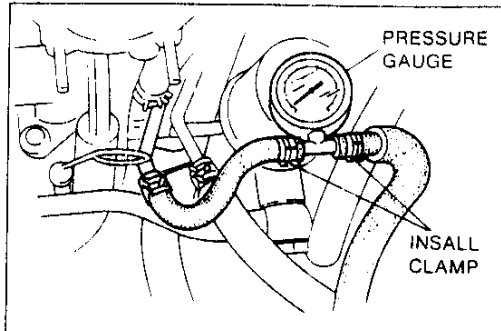
**Removal / Installation**

(Refer to page F-105)

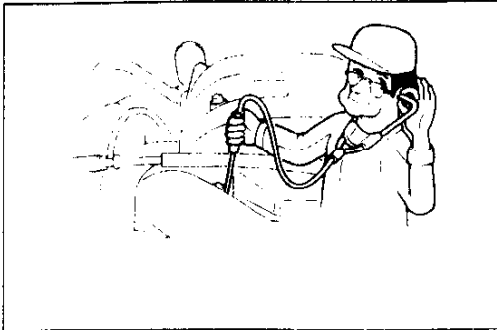

INJECTOR

Inspection (On-vehicle)

1. Warm up the engine and run it idle.
2. Listen for the operational sound of primary injector with a screwdriver or a sound scope.

Removal / Installation

Warning

- Before performing the following operation, release the fuel pressure from the fuel system to reduce the possibility of injury or fire. (Refer to page F-96.)
- When removing the fuel system components, keep sparks, cigarettes, and open flames away from the fuel.

1. Remove in the order shown in the figure.
2. Install in the reverse order of removal, referring to Installation Note.

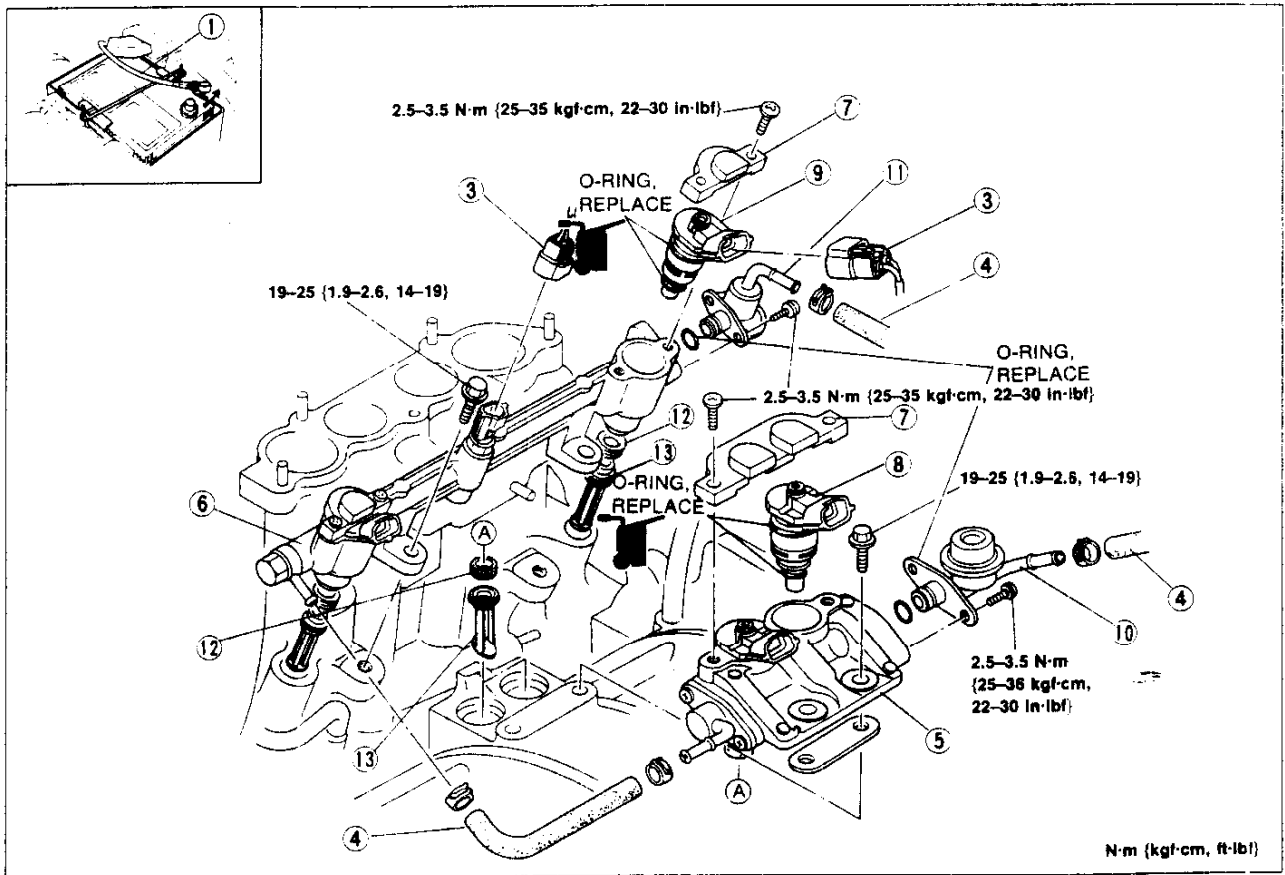

37U0FX 093

- | | |
|--|-----------------------------|
| 1. Negative battery cable | 8. Injector (Primary) |
| 2. Extension manifold (Refer to page F-76) | Inspection page F-107 |
| 3. Connector | 9. Injector (Secondary) |
| 4. Fuel hoses | Inspection page F-107 |
| 5. Fuel distributor assembly (Primary) | 10. Pulsation damper |
| 6. Fuel distributor assembly (Secondary) | 11. Pressure regulator |
| 7. Cover | Inspection page F-104 |
| | 12. Insulator |
| | 13. Air bleed socket |

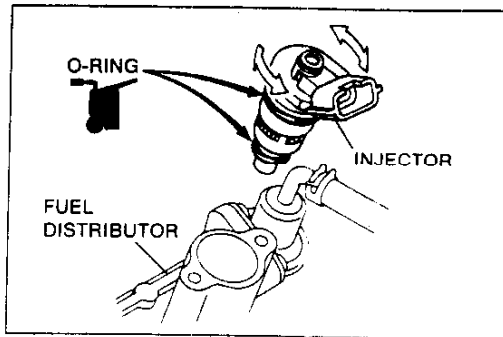

Installation Note Injector Installation

1. Use new O-rings.
2. Apply a small amount of clean engine oil to the O-rings before installing them.
3. Install the injector squarely into fuel distributor and gradually twist it.
4. Verify that the deposit is not to the holder inside of fuel distributor.
5. If there is, clean the holder inside by used to gasolir e.

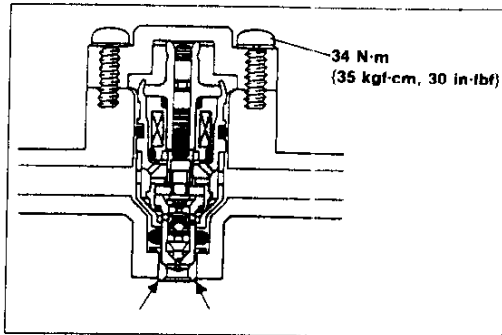

Fuel leakage test

1. Install the fuel hose.
2. Connect the diagnosis connector terminals F/P and GND with a jumper wire.
3. Turn the ignition switch ON and check for fuel leaks from the fuel distributor.
4. If fuel leaks check the injector O-ring and fuel distributor.

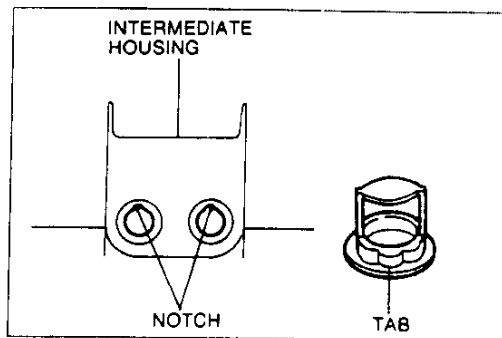

Air bleed socket installation

Align the tab of the air bleed socket with the notches in the intermediate housing.

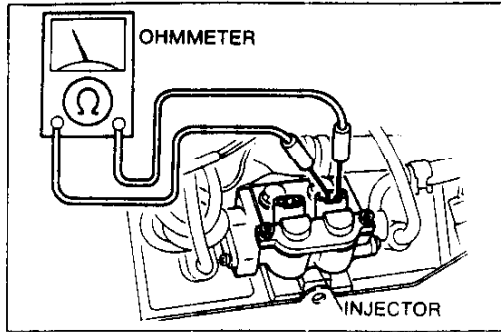

Inspection

Caution

- Do not remove the injector from the fuel distributor if it is not necessary.

Injector resistance

1. Disconnect injector connector as shown in figure.
2. Measure the resistance of the injection with an ohmmeter.

Resistance: Approx. 13.8 Ω {20°C [68°F]}

3. If not as specified, replace the injector.

Fuel leakage test

1. Remove the injector together with fuel distributor.
2. Connect the **SST** as shown in figure.
3. Connect the diagnosis connector terminals F/P and GND with a jumper wire.
4. Turn the ignition switch ON and check for fuel leaks from the injector.

Fuel leakage: Less than 1 drop / 5 min.

5. If not as specified, check the injector O-ring and fuel distributor contact face.

Note

- Perform the following installation carefully to prevent fuel leakage from O-ring.

6. Install the injector.
7. Turn the ignition switch ON and check for fuel leaks from injector.
8. If not as specified replace the injector.

Volume Test

1. Remove the injectors together with the fuel distributor.
2. Connect the **SST** as shown in figure.

Warning

- Be extremely careful when working with fuel. Always work away from sparks and open flames.

3. Check the injection volume with a graduated container.

Injection volume

Primary injector:

128–147 cc {7.8–8.9 cuin} / 15 sec.

Secondary injector:

198–227 cc {12.0–13.8 cuin} / 15 sec.

4. If not as specified, replace the injector.

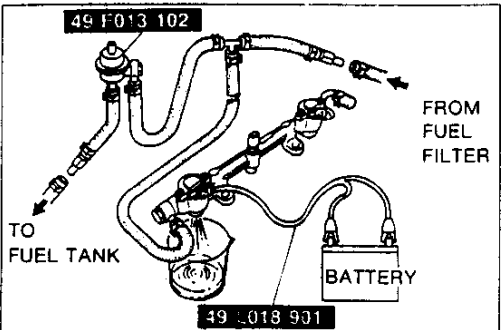
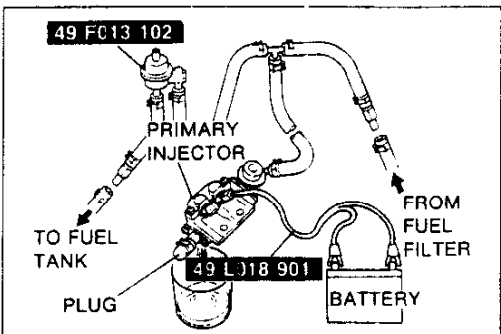
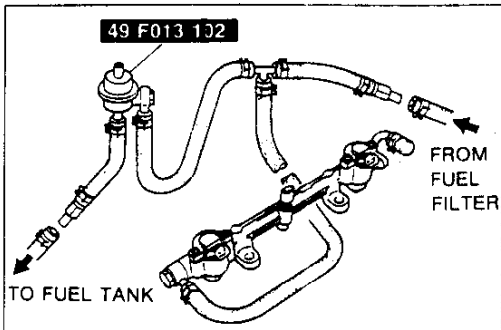
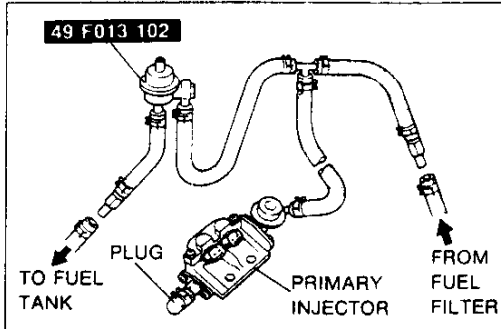

F

FUEL SYSTEM

FUEL PUMP CONTROL SYSTEM

Description

- The ECU turns the fuel pump ON/OFF via the circuit opening relay. By controlling the fuel pump relay, the ECU also controls fuel pump operation in two phases to improve fuel pump reliability and ensure the necessary fuel amount.

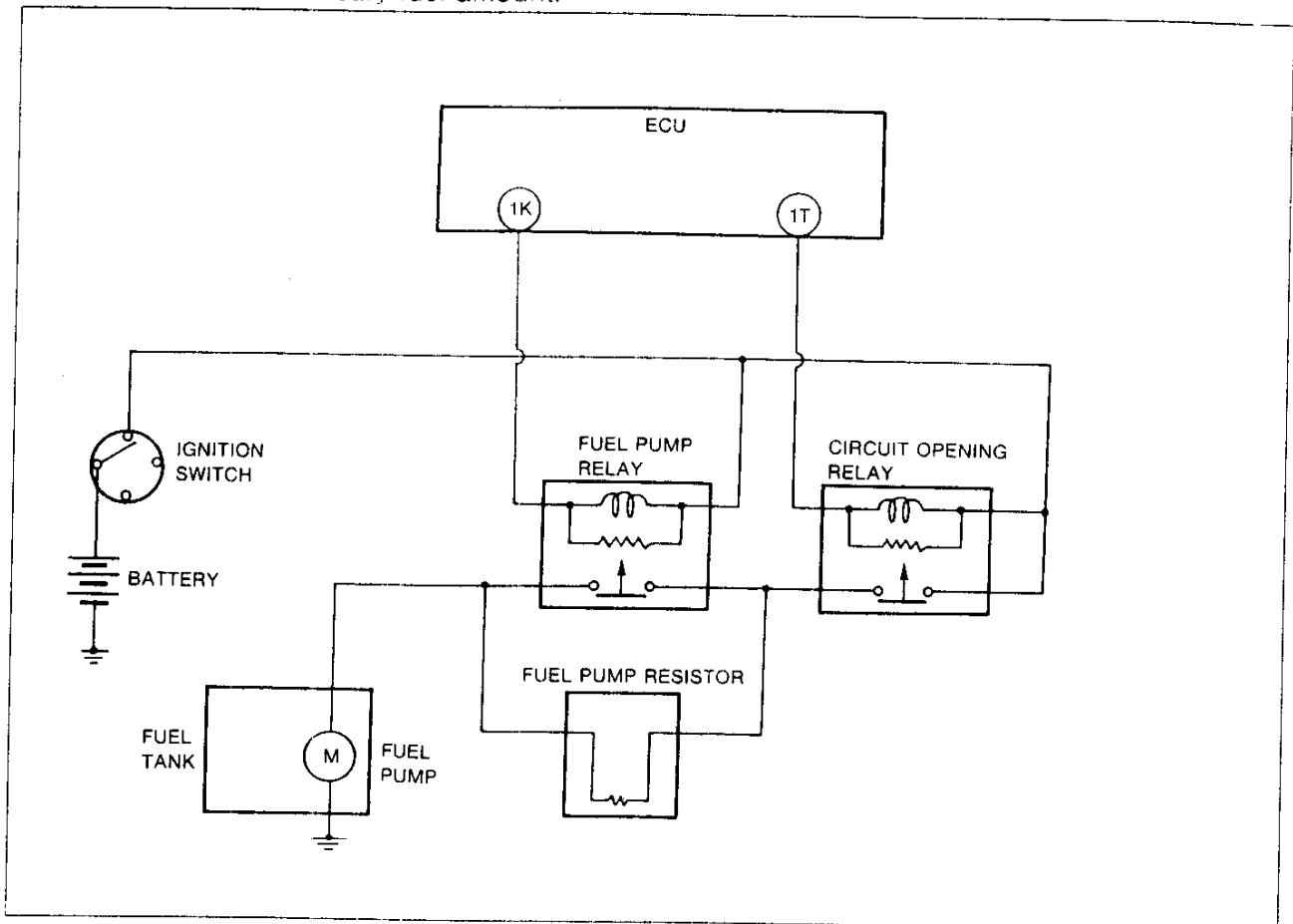

37UOFX-529

Circuit opening relay

- The circuit opening relay is controlled by the ECU and turns the fuel pump ON/OFF.

Fuel pump relay

- The fuel pump relay is controlled by the ECU and controls fuel pump operation voltage via the fuel pump relay.

Fuel pump resistor

- The fuel pump resistor controls fuel pump operation voltage. During low-speed engine operation, fuel pump voltage is supplied via the fuel pump resistor.

Operation

- (1) In low-speed range (1K terminal of ECU is battery voltage)
 - The fuel pump is driven by voltage from the fuel pump resistor.
- (2) In high-speed range (1K terminal of is 0V)
 - The fuel pump is driven by battery voltage.

Operating conditions

The system operates when either of the following conditions is met.

- During engine start-up
- Solenoid valve (pressure regulator control) operating
- High speed and heavy load

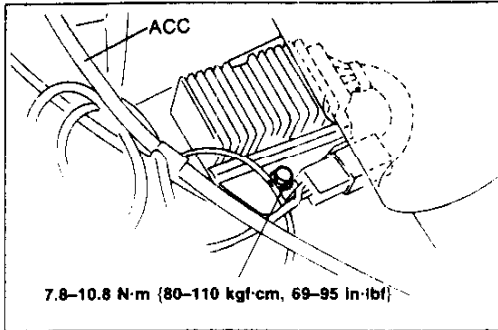

FUEL PUMP RESISTOR

Removal / Installation

1. Remove in the order as shown in the figure.
2. Install in the reverse order of removal.

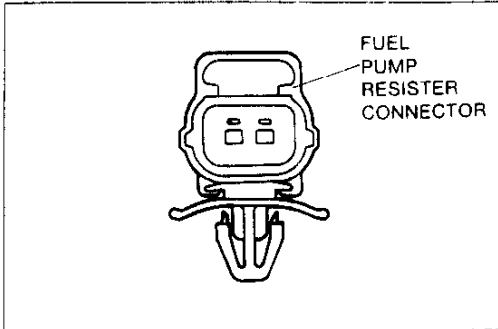

Inspection

1. Disconnect fuel pump resistor connector.
2. Measure resistance of the fuel pump resistor with an ohmmeter.

Resistance 0.57-0.70 Ω {at 20°C [68°F]}

3. Replace the fuel pump resistor if necessary.

FUEL SYSTEM

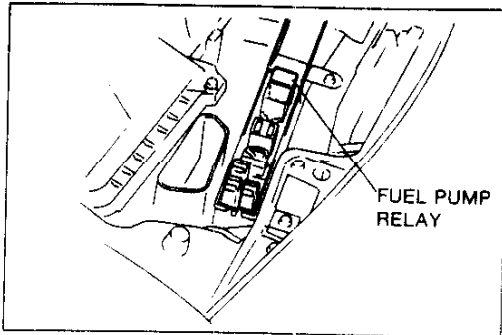

FUEL PUMP RELAY

Inspection

Operation check

Listen for operational sound of the fuel pump relay when ignition switch ON.

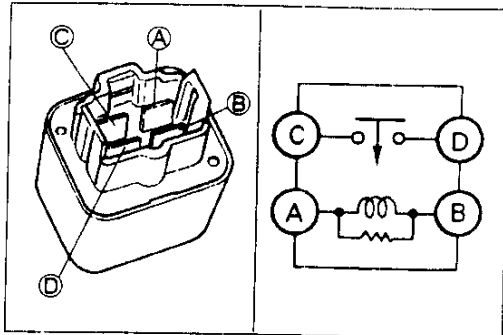

Continuity inspection

Check continuity between the terminals with ohmmeter:

Terminal A-B	Terminal C-D
Apply V_e	Yes
Not apply V_B	No

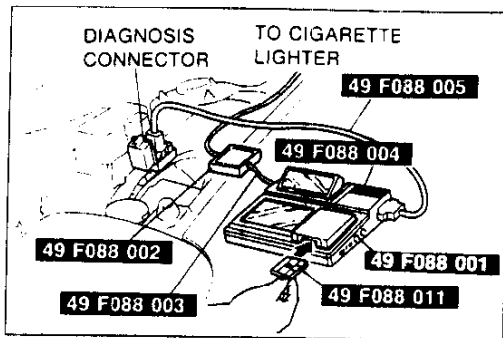

DT-S1000

Operation check

1. Connect the **SSTs** (DT-S1000 and Harness) to the diagnosis connector as shown.
2. Turn ignition switch ON.

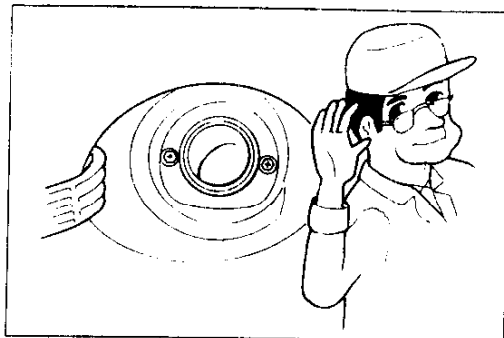

3. Select the simulation check and verify that the fuel pump relay operation sound is heard.
4. If no sound is heard check continuity of fuel pump relay.

PRESSURE REGULATOR CONTROL (PRC) SYSTEM

DESCRIPTION

- This system cancels the vacuum applied to the pressure regulator and increases the fuel pressure during hot engine start-up and for a period immediately following engine start-up. This improves hot starting as well as providing smooth idle.

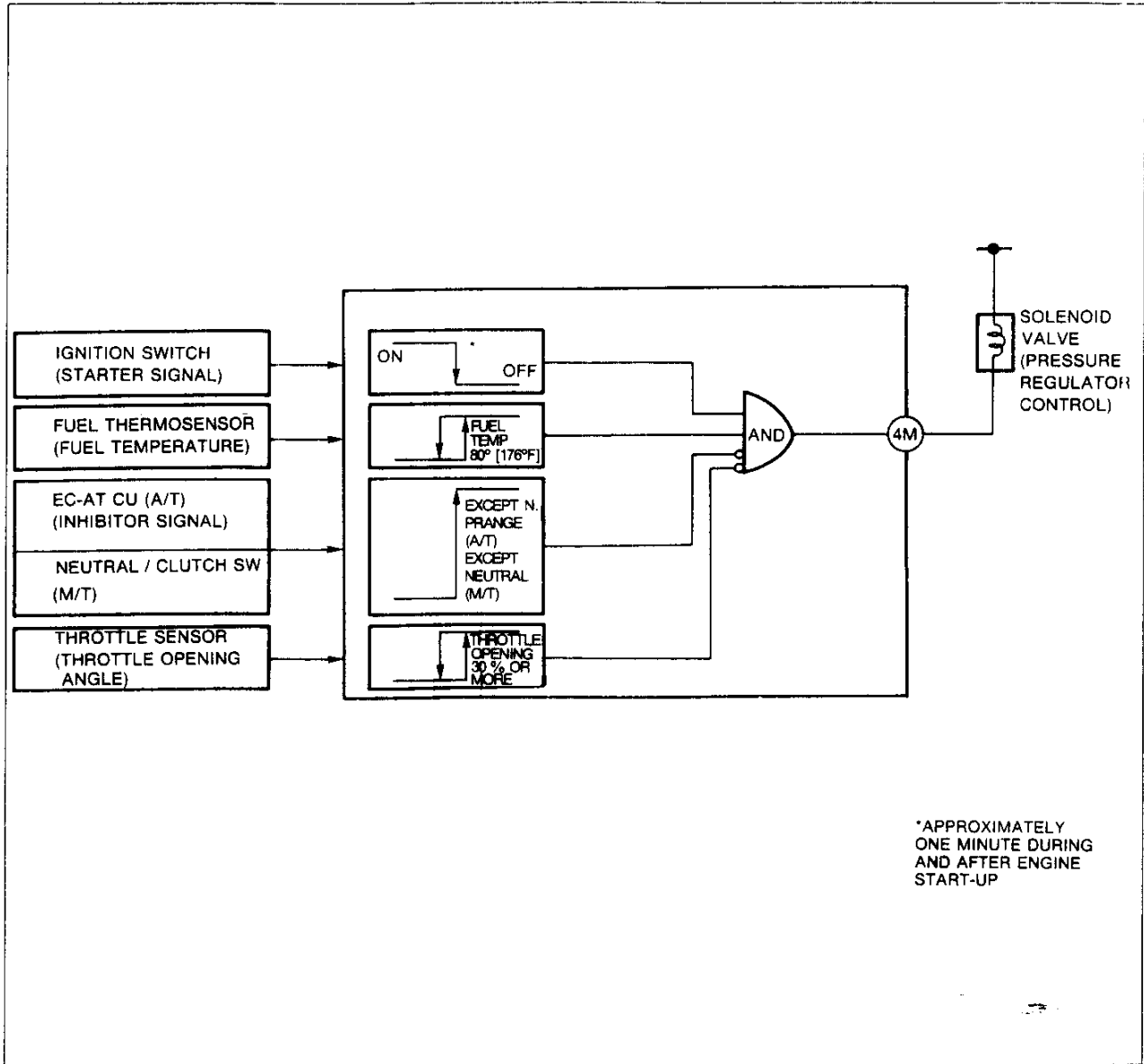





Operation

To prevent vapor-lock during hot restart idle, vacuum to the pressure regulator is momentarily cut, and fuel injection pressure is increased.

F

PRESSURE REGULATOR CONTROL (PRC) SYSTEM

PREPARATION SST

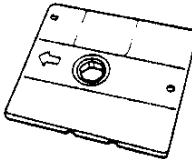
49 F088 001 DT-S1000 Base unit		For inspection of solenoid valve and relay	49 F088 002 Power unit (DC12V)		For inspection of solenoid valve
49 F088 003 Harness Power unit		For inspection of solenoid valve	49 F088 004 Interface adapter Type-1		For inspection of solenoid valve
49 F088 005 Harness Type-1		For inspection of solenoid valve	49 F088 011 System disk Type-1 (Ver 1.00)		For inspection of solenoid valve

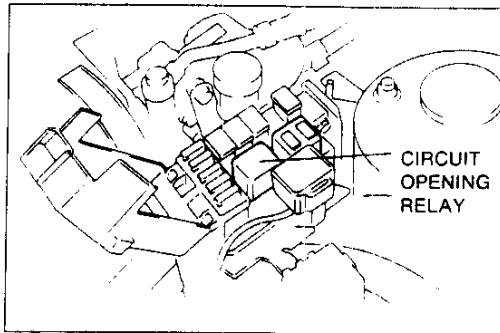

SYSTEM OPERATION

Warning

- Before performing the following operation, release the fuel pressure from the fuel system to reduce the possibility of injury or fire. (Refer to page F-96.)

1. Remove the circuit opening relay.
2. Connect a fuel pressure gauge to the main hose.
3. Connect the circuit opening relay.
4. Start the engine and run it idle.
5. Verify the fuel pressure.

Fuel line pressure

190–220 kPa {1.9–2.3 kgf/cm², 28–32 psi}

6. Short the ECU Terminal 4M and verify that fuel pressure.

Fuel line pressure

250–260 kPa {2.5–2.7 kgf/cm², 36–38 psi}

7. If not as specified, check the pressure regulator and solenoid valve.

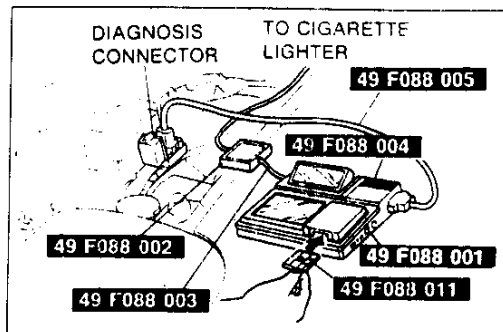
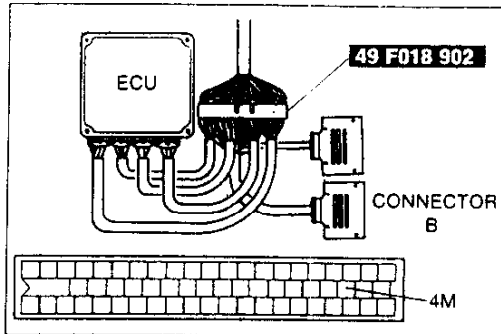

DT-S1000

1. Remove the circuit opening relay.
2. Connect a fuel pressure gauge to the main hose.
3. Connect the circuit opening relay.
4. Connect the DT-S1000 to the diagnosis connector.
5. Start the engine and run it idle.
6. Select the simulation check and verify that the fuel line pressure increase when solenoid valve ON.
7. If fuel line pressure does not increase, check the operation sound of solenoid valve.

EXHAUST SYSTEM

COMPONENT PARTS

Inspection (On-vehicle)

Start the engine and verify that there is no exhaust gas leakage from the exhaust system components.

Removal / Inspection / Installation

1. Remove in the order shown in the figure.
2. Check all parts and repair or replace if necessary.
3. Install in the reverse order of removal, referring to **Installation Note**.

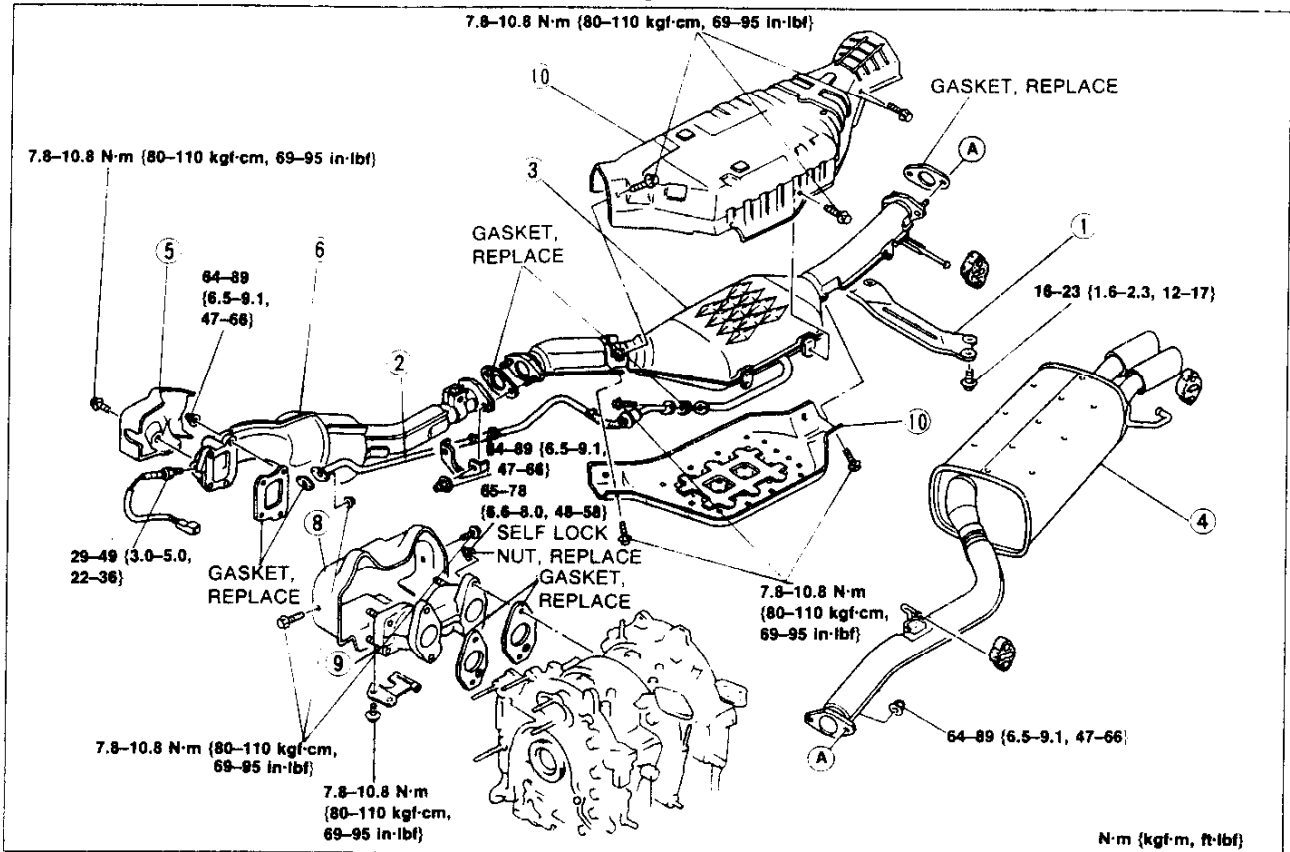

- | | |
|--|--|
| 1. Bracket | 6. Front converter
Inspect for deterioration and restriction |
| 2. Secondary air pipe.
Inspect for deterioration and restriction. | 7. Turbocharger
Removal Refer to page F-89 |
| 3. Main converter
Inspect for deterioration and restriction. | 8. Insulator |
| 4. Main silencer
Inspect for deterioration and restriction. | 9. Exhaust manifold
Inspect for deterioration and restriction |
| 5. Insulator | 10. Insulator |

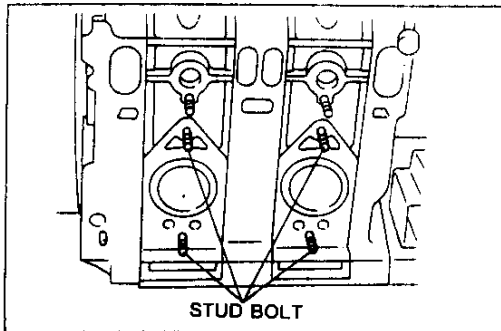

Installation Note

1. Check the stud bolt tightening torque before installing exhaust manifold.

Tighting torque: 30-35 N-m {3.0-3.6 kgf-m, 22-26 ft-lbf}

F

OUTLINE OF EMISSION SYSTEM

OUTLINE OF EMISSION SYSTEM

STRUCTURAL VIEW

The following systems are employed to reduce CO, HC, and NOx emissions.

1. Secondary air injection system
2. Positive crankcase ventilation system
3. Evaporative emission control system
4. Catalytic converter
5. Deceleration control system
6. Exhaust gas recirculation control system

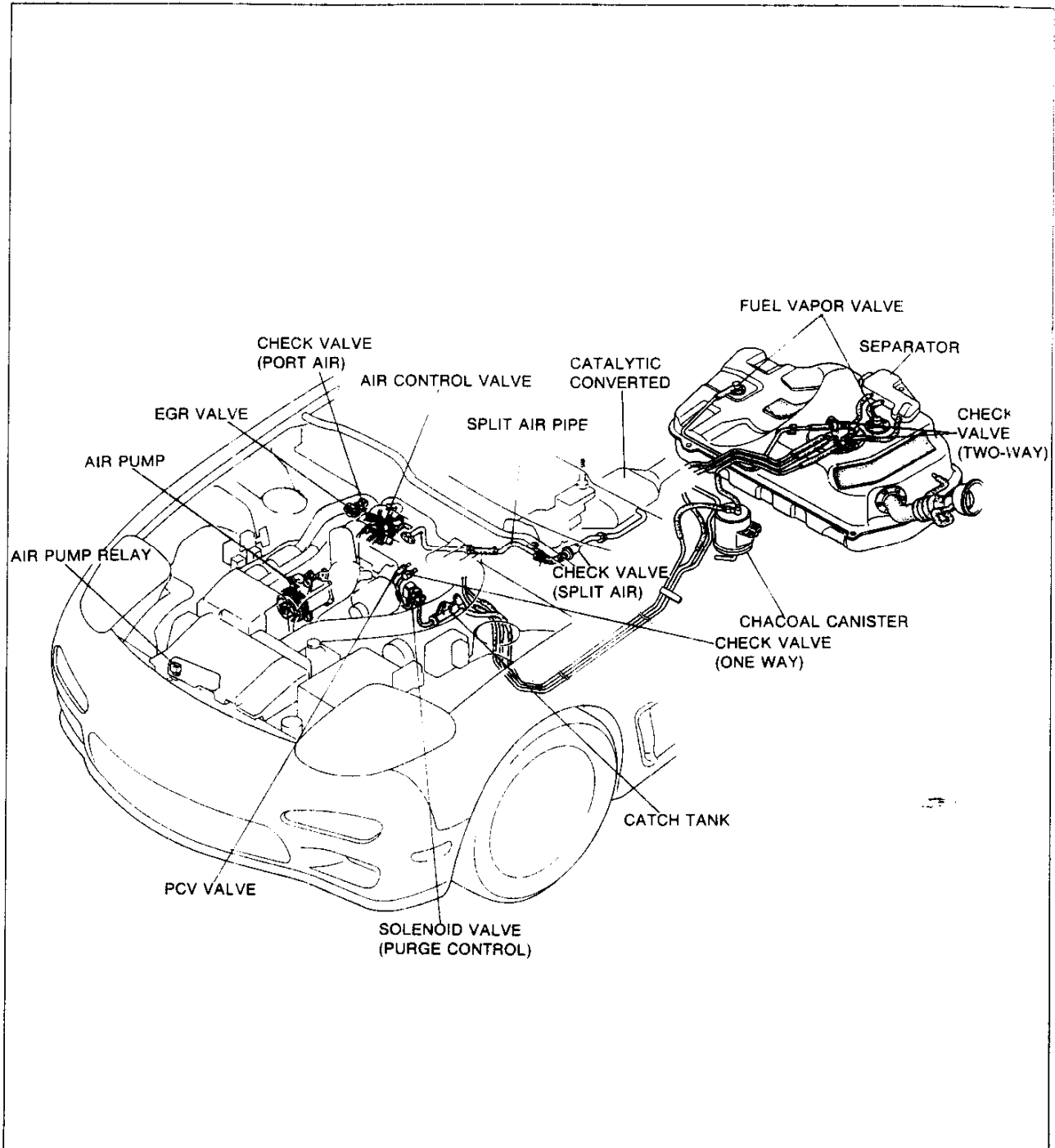

SECONDARY AIR INJECTION SYSTEM

DESCRIPTION

The secondary air injection system helps to clean the exhaust gas by introducing fresh air into the exhaust port or catalytic converter in relation to the during condition.

The ECU controls secondary air by actuating the solenoid valves (switching, relief 1, 2, port air bypass, split air bypass) and the air pump relay.



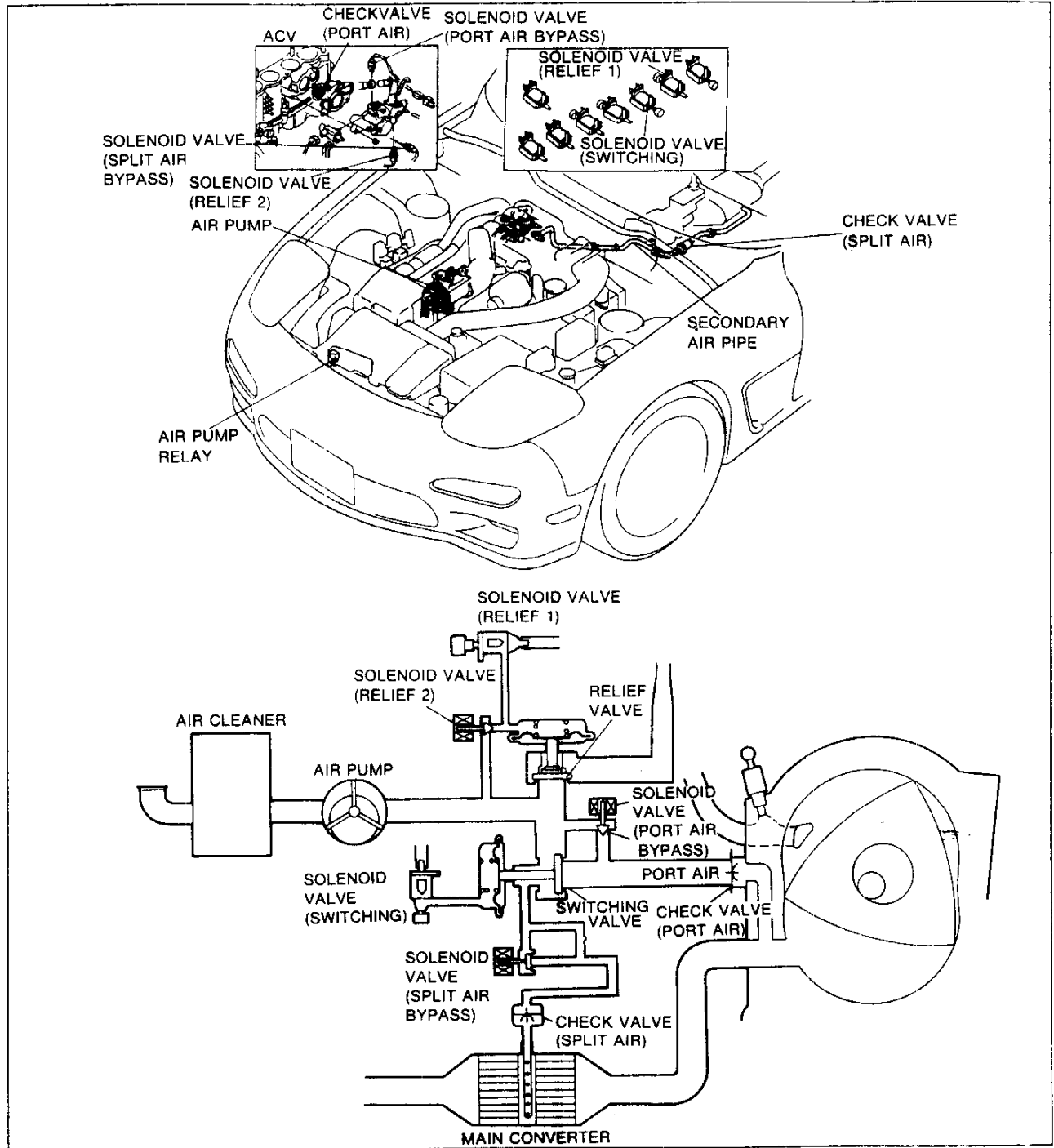

This system consist of an air control valve (ACV), three way solenoid valves, air pump relay and Engine control unit.



F

SECONDARY AIR INJECTION SYSTEM

PREPARATION SST

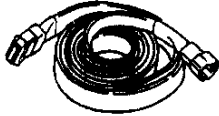
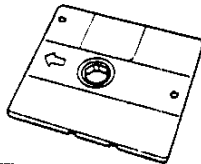
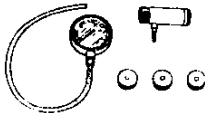
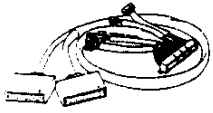
<p>49 F088 001 DT-S1000 Base unit</p>		<p>For inspection of solenoid valve and relay</p>	<p>49 F088 002 Power unit (DC12V)</p>		<p>For inspection of solenoid valve</p>
<p>49 F088 003 Harness Power unit</p>		<p>For inspection of solenoid valve</p>	<p>49 F088 004 interface adapter Type-1</p>		<p>For inspection of solenoid valve</p>
<p>49 F088 005 Harness Type-1</p>		<p>For inspection of solenoid valve</p>	<p>49 F088 011 System disk Type-1 (Ver 1.00)</p>		<p>For inspection of solenoid valve</p>
<p>49 2113 011B Air pump gauge set</p>		<p>For inspection of air pump</p>	<p>49 F018 902 Adapter harness</p>		<p>For inspection of solenoid valve</p>

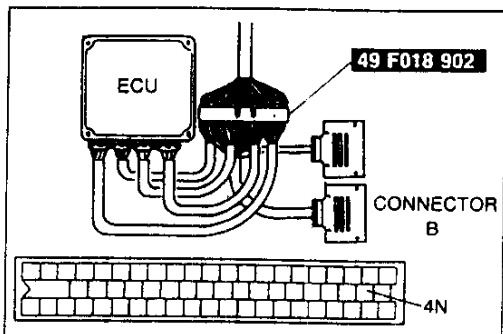

AIR CONTROL VALVE (ACV) SWITCHING VALVE

System operation
Engine Signal Monitor

1. Connect the **SSTs** (Engine Signal Monitor and Adapter Harness) to the ECU as shown.
2. Start the engine and run it idle.
3. Short the ECU terminal 4N and verify that the engine condition change (idle roughing)
4. If the engine condition does not change, check the following below.

- Vacuum tube
Inspect the vacuum line fitting, connections and components for leaks. (Refer to page F-10.)
- Solenoid valve (Switching)
Inspection (Refer to page F-19.)
- Air relief valve
Inspection (Refer to page F-117)
- Air pump
Inspection (Refer to page F-121)
- Air pump relay
Inspection (Refer to page F-123)

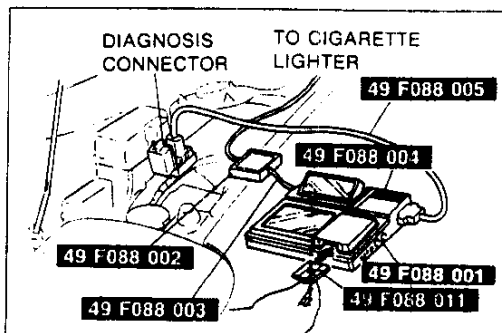
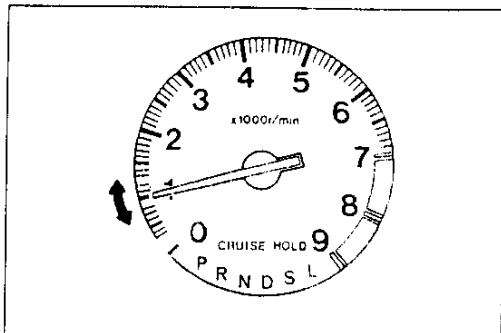

DT-S1000

1. Connect the **SSTs** (DT-S1000 and Harness) to the diagnosis connector as shown.
2. Start the engine and run it idle.
3. Select the simulation check and verify that the engine condition change at idle (idle roughing) when solenoid valve (Switching) to ON.
4. If the engine condition does not change, stop the engine and turn ignition switch ON.
5. Select the simulation check and verify that the solenoid valve (Switching) operation sound is heard.
6. If the solenoid valve operation sound is not heard check the condition above.

Inspection

1. Remove the air control valve. (Refer to page F-119)
2. Connect a vacuum pump to port A.
3. Verify that the switching valve opens at a vacuum 14.7 kPa {110 mmHg, 4.3 inHg}

Caution

- Do not apply vacuum more than 66.7 kPa {500 mmHg, 19.7 inHg}
4. If not as specified, replace air control valve. (Refer to page F-119)

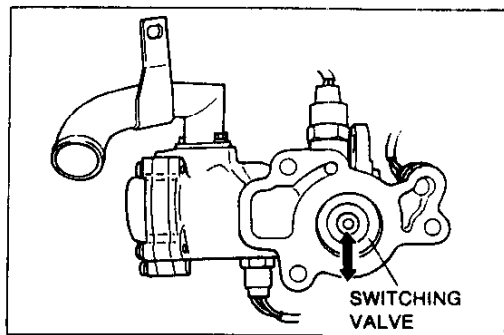
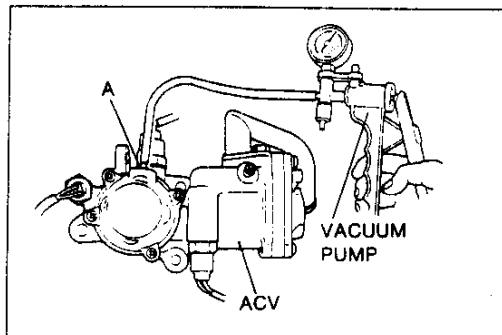

F

SECONDARY AIR INJECTION SYSTEM

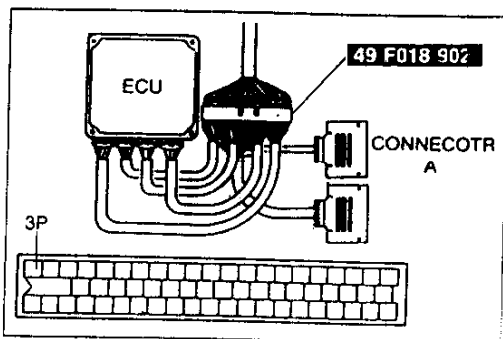

Air Relief Valve System operation Engine Signal Monitor

1. Connect the **SSTs** (Engine Signal Monitor and Adaptor Harness) to the ECU as shown.
2. Start the engine and run it idle.
3. Verify that air does not flow from air relief valve.
4. Short the ECU terminal 3P and verify that the air flows from air relief valve.
5. If the air does not flow, check the following condition below.

- Vacuum tube
Inspect the vacuum line fitting, connections and components for leaks. (Refer to page F-10)
- Solenoid valve (Relief 1)
Inspection (Refer to page F-190)
- Air pump
Inspection (Refer to page F-121)
- Air pump relay.
Inspection (Refer to page F-123)

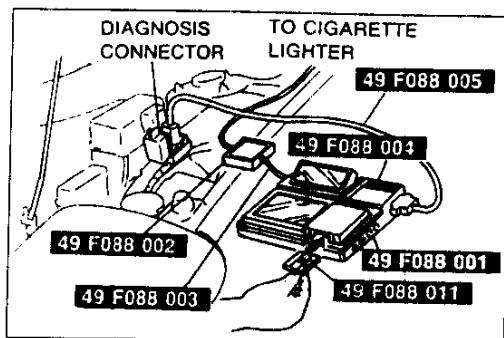
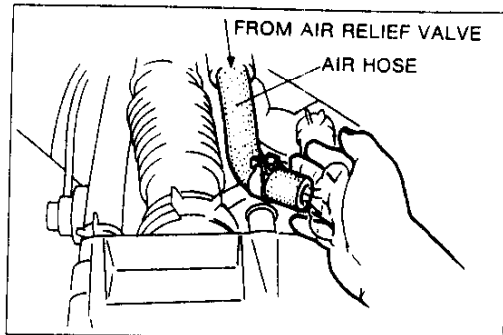

DT-S1000

1. Connect the **SSTs** (DT-S1000 and Harness) to the diagnosis connector as shown.
2. Start the engine and run it idle.
3. Verify that air does not flow from air relief valve.
4. Select simulation check and verify that the air flows from air relief valve when solenoid valve (air relief) is ON.
5. If the air does not flow from air relief valve, stop the engine and turn ignition switch ON.
6. Select simulation check and verify that the solenoid valve (air relief) operational sound is heard.
7. If the solenoid valve operational sound is not heard check the condition above.

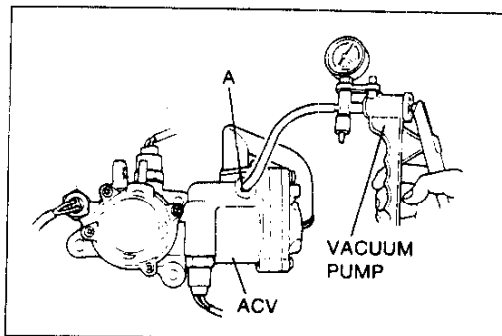

Inspection

1. Remove the air control valve (Refer to page F-119)
2. Connect a vacuum pump to port A

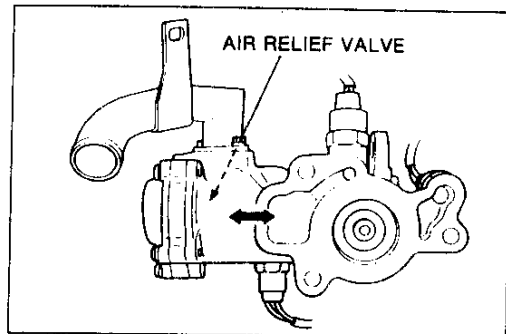

3. Verify that the air relief valve opens at a vacuum 19.3 kPa {145 mmHg, 5.7 inHg}

Caution

- Do not apply vacuum More than 66.7 kPa {500 mmHg, 19.7 inHg}
4. If not as specified, replace air control valve.

Removal / Installation

1. Remove the extension manifold. (Refer to page F-76)
2. Remove in the order shown in the figure.
3. Install in the reverse order of removal.

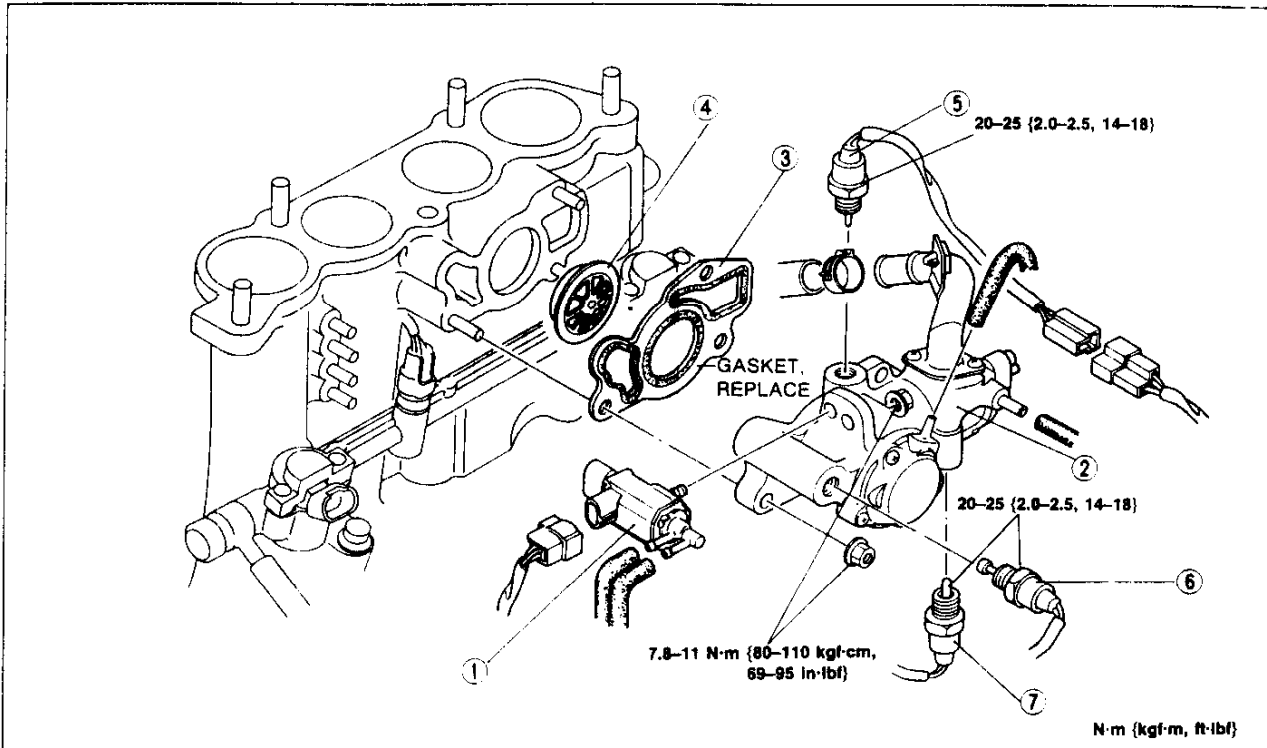

- | | |
|--|---|
| 1. Solenoid valve (Turbo control)
Inspection page F-190 | 5. Solenoid valve (Port air bypass)
Inspection below |
| 2. Air control valve | 6. Solenoid valve (Split air bypass)
Inspection page F-120 |
| 3. Gasket | 7. Solenoid valve (Relief2)
Inspection page F-123 |
| 4. Check valve (Port air)
Inspection page F-120 | |

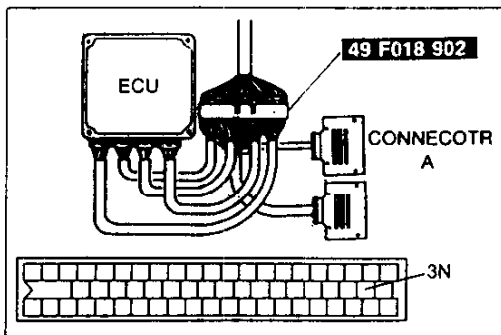

SOLENOID VALVE (PORT AIR BYPASS)

**System Operation
Engine Signal Monitor**

1. Connect the **SSTs** (Engine Signal Monitor Adaptor Harness) to the ECU.
2. Turn ignition switch ON.
3. Short the ECU terminal 3N and verify that the operational sound is heard.

DT-S1000

1. Connect the **SSTs** (DT-S1000 and Harness) to the diagnosis connector.
2. Turn ignition switch ON.
3. Select simulation check (port air bypass) and verify that the operational sound is heard.

Inspection

1. Disconnect the solenoid valve (Port air bypass) connector.
2. Measure the solenoid valve resistance with an ohmmeter.

Resistance: 26.6-32.6 Ω (20°C [68°F])

3. If not as specified replace solenoid valve. (Refer to page F-190)

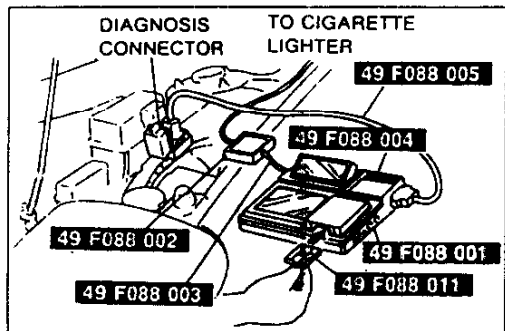

F

SECONDARY AIR INJECTION SYSTEM

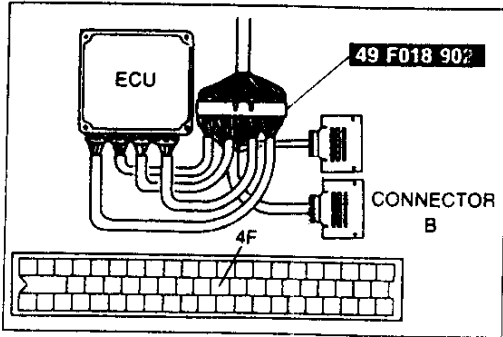

SOLENOID VALVE (SPLIT AIR BYPASS)

System Operation

1. Connect the **SSTs** (Engine Signal Monitor Adaptor Harness) to the ECU.
2. Turn ignition switch ON.
3. Short the ECU terminal 4F and verify that the operational sound is heard.

DT-S1000

1. Connect the **SSTs** (DT-S1000 and Harness) to the diagnosis connector.
2. Turn ignition switch ON.
3. Select simulation check and verify that the operational sound is heard.

Inspection

1. Disconnect the solenoid valve.
2. Measure the solenoid valve resistance with an ohmmeter.

Resistance: 27–32 Ω (20°C [68°F])

3. If not as specified, replace solenoid valve.

CHECK VALVE (PORT AIR)

Inspection

1. Disconnect the air hose (From air pump to air control valve) at the air control valve.
2. Start the engine and run it idle.
3. Verify that the exhaust gas does not flow from air control valve.
4. If the exhaust gas flows from air control valve replace the check valve (port air) (Refer to page F-119)

CHECK VALVE (SPLIT AIR)

Inspection

1. Disconnect the air hose (From air control valve to air pipe) at the air pipe.
2. Connect a tachometer to the engine.
3. Start the engine.
4. Increase the engine speed to 2,000 rpm and verify that the exhaust gas does not flow from split air pipe.
5. If not as specified, replace the check valve (Split air)

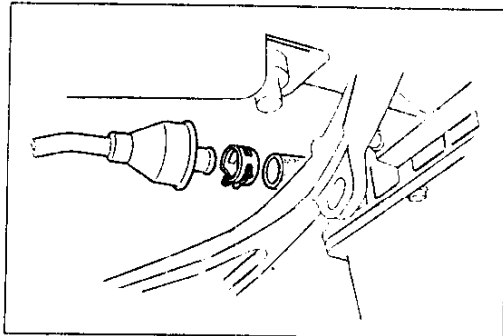
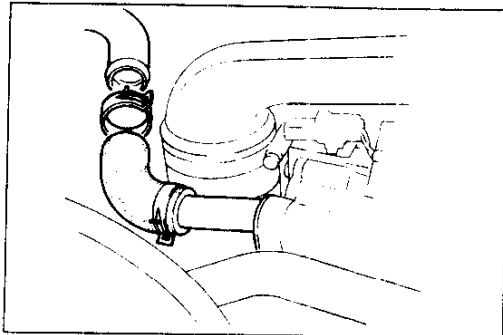
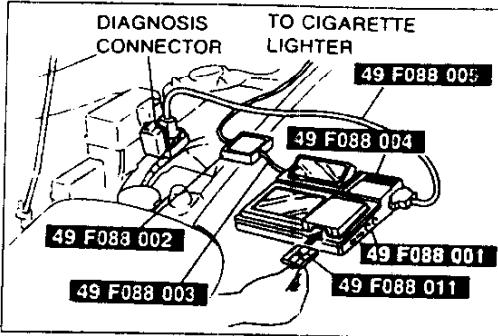

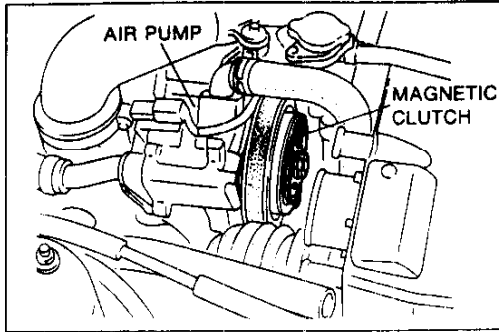

AIR PUMP

System Operation

1. Start the engine.
2. Increase the engine speed to above 3250 rpm and verify that the air pump magnetic clutch OFF.

Inspection

Magnetic clutch

Engine signal monitor

1. Connect the **SST** (Engine Signal Monitor Adaptor Harness) to the ECU.
2. Turn ignition switch ON.
3. Short the ECU terminal 2J and verify that the magnetic clutch OFF.
4. If the magnetic clutch does not OFF check the Air pump relay. (Refer to page F-123)
5. If the relay is OK, disconnect the air pump connector and check the continuity.
6. If not as specified, replace the air pump.

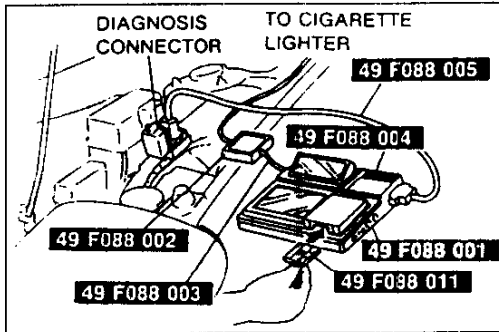
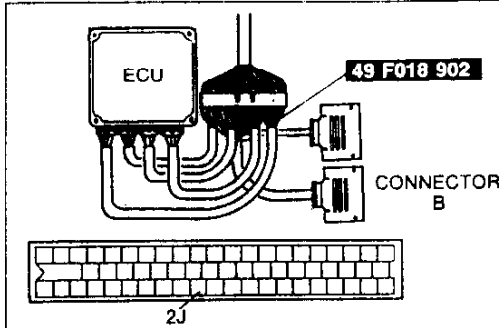

DT-S1000

1. Connect the **SST** (DT-S1000 and Harness) to the diagnosis connector.
2. Turn ignition switch ON.
3. Select a simulation check (air pump relay) and verify that the magnetic clutch ON and OFF.
4. If the magnetic clutch does not ON OFF check the air pump relay. (Refer to page F-123)
5. If the relay is OK, disconnect the air pump connector and check the continuity.
6. If not as specified, replace the air pump.

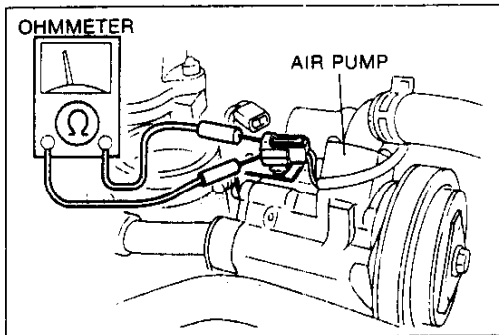

Continuity

1. Disconnect the air pump connector.
2. Check for continuity between terminals.
3. If no continuity, replace the air pump.

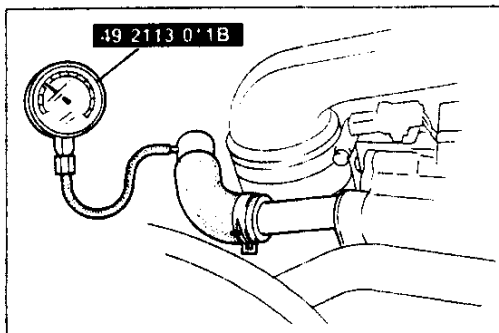

Pressure

1. Disconnect air hose (from air control valve to air pump) at the air control valve.
2. Connect the **SST** to the air hose.
3. Start the engine and run it idle.
4. Measure the pressure.

Pressure

More than 4.9 kPa {0.05 kgf/cm², 0.7 psi}

5. If not as specified, replace the air pump.

F

SECONDARY AIR INJECTION SYSTEM

Removal / Installation

1. Remove in the order in the figure.
2. Install in the reverse order of removal.

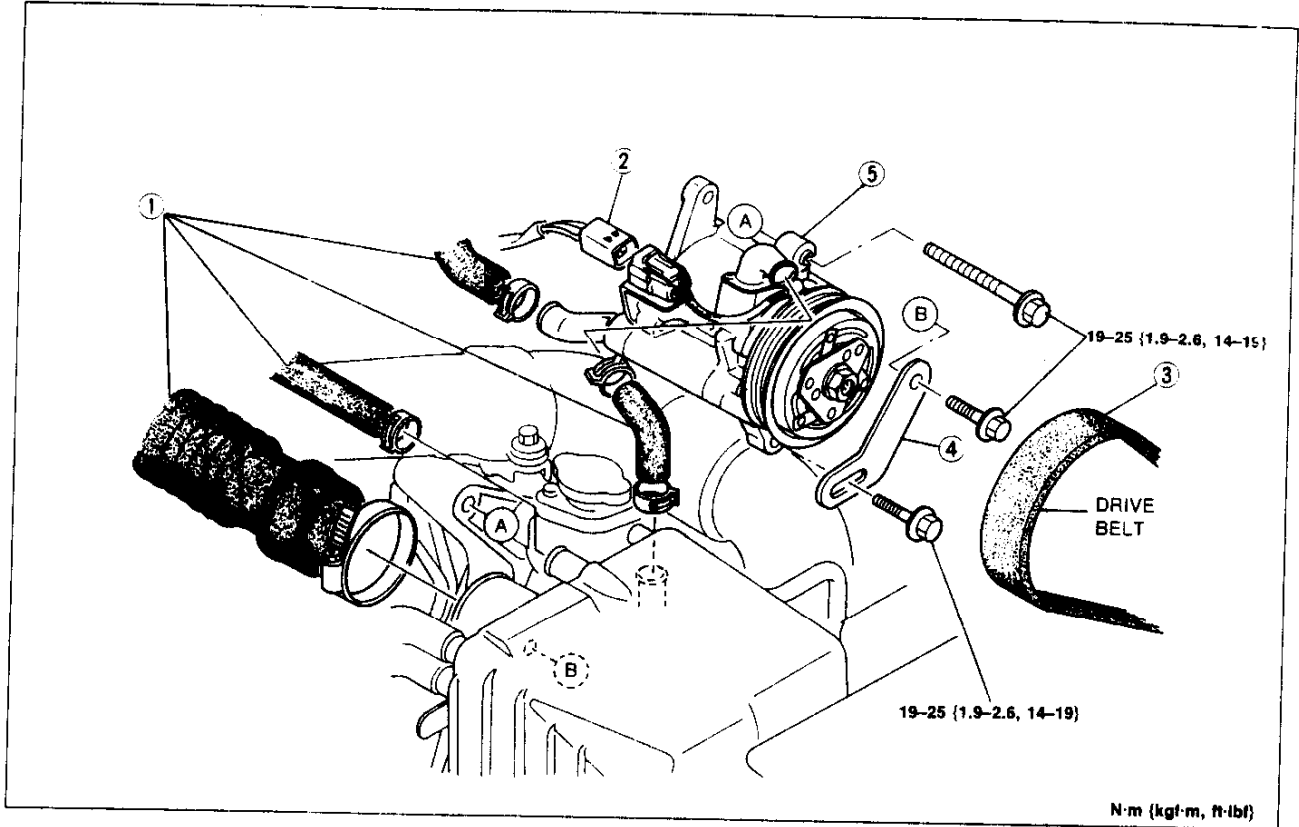

1. Air hoses
2. Connector
3. Drive belt

Inspection below

4. Bracket
5. Air pump

Inspection page F-121

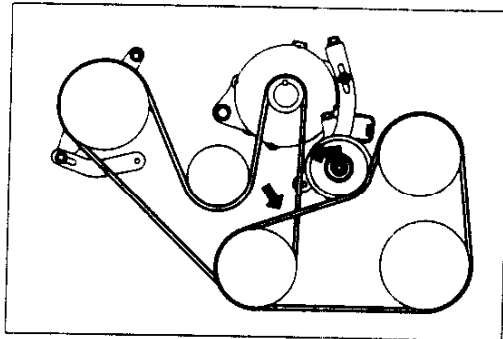

AIR PUMP DRIVE BELT

Inspection

1. Check the drive belt for cracks deterioration or oil contamination.
2. Replace if necessary.
3. If the belt is noisy, check for loose or misaligned pulleys.

Adjustment

Refer to section C

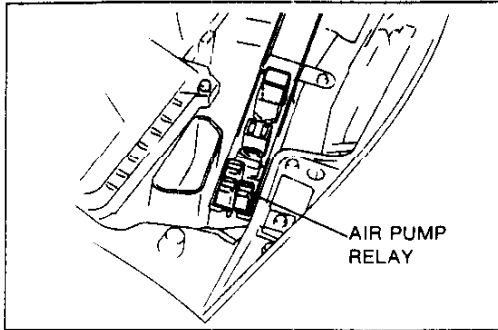

AIR PUMP RELAY

Inspection (On-vehicle)

Check that a "clicking" sound is heard at the Air pump relay when turning the ignition switch ON and OFF.

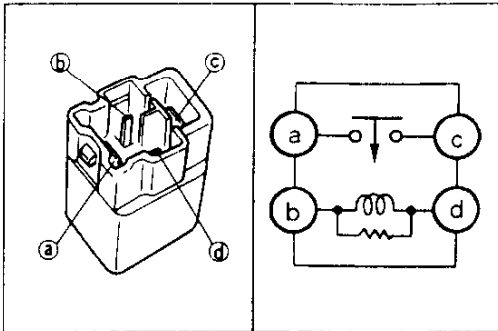

Inspection

1. Disconnect the air pump relay.
2. Apply Battery voltage and ground to terminals B and D of the relay.
3. Check continuity of the relay.

Operation	A-C terminals
V _B Applied	Continuity
V _B Not applied	No continuity

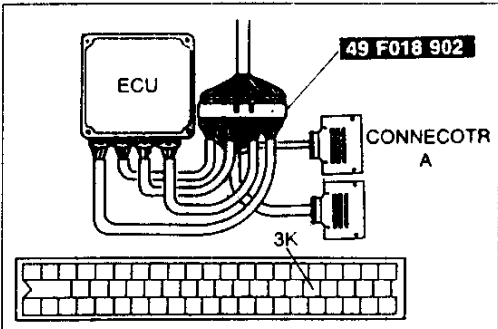

SOLENOID VALVE (RELIEF2)

System Operation

Engine Signal Monitor

1. Connect the **SST** (Engine Signal Monitor Adaptor Harness) to the ECU.
2. Turn ignition switch ON.
3. Short the ECU terminal 3K and verify that the operation sound is heard.

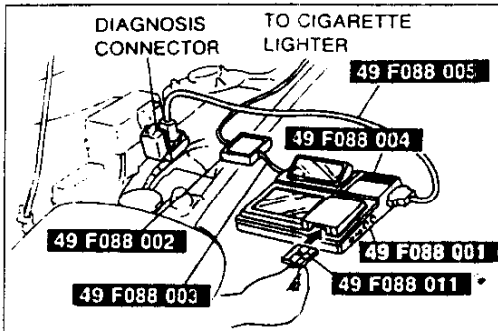

DT-S1000

1. Connect the **SST** (DT-S1000 and Harness) to the diagnosis connector.
2. Turn ignition switch ON.
3. Select simulation check (RELIEF 2) and verify that the operation sound is heard.

Inspection

1. Disconnect the solenoid valve. (Refer to page F-119)
2. Measure the solenoid valve resistance with an ohmmeter.

Resistance 27-32 Ω {20°C [68°F]}

3. If not as specified, replace solenoid valve. (Refer to page F-119)

F

POSITIVE CRANKCASE VENTILATION (PCV) SYSTEM

POSITIVE CRANKCASE VENTILATION (PCV) SYSTEM

DESCRIPTION

The PCV valve is operated by the intake manifold vacuum.

When the engine is running at idle, the PCV valve is opened slightly and a small amount of blow by gas is drawn into the dynamic chamber to be burned.

As the engine speed rises the PCV valve is opened further, allowing a larger amount of blow by gas to be drawn into the intake manifold.

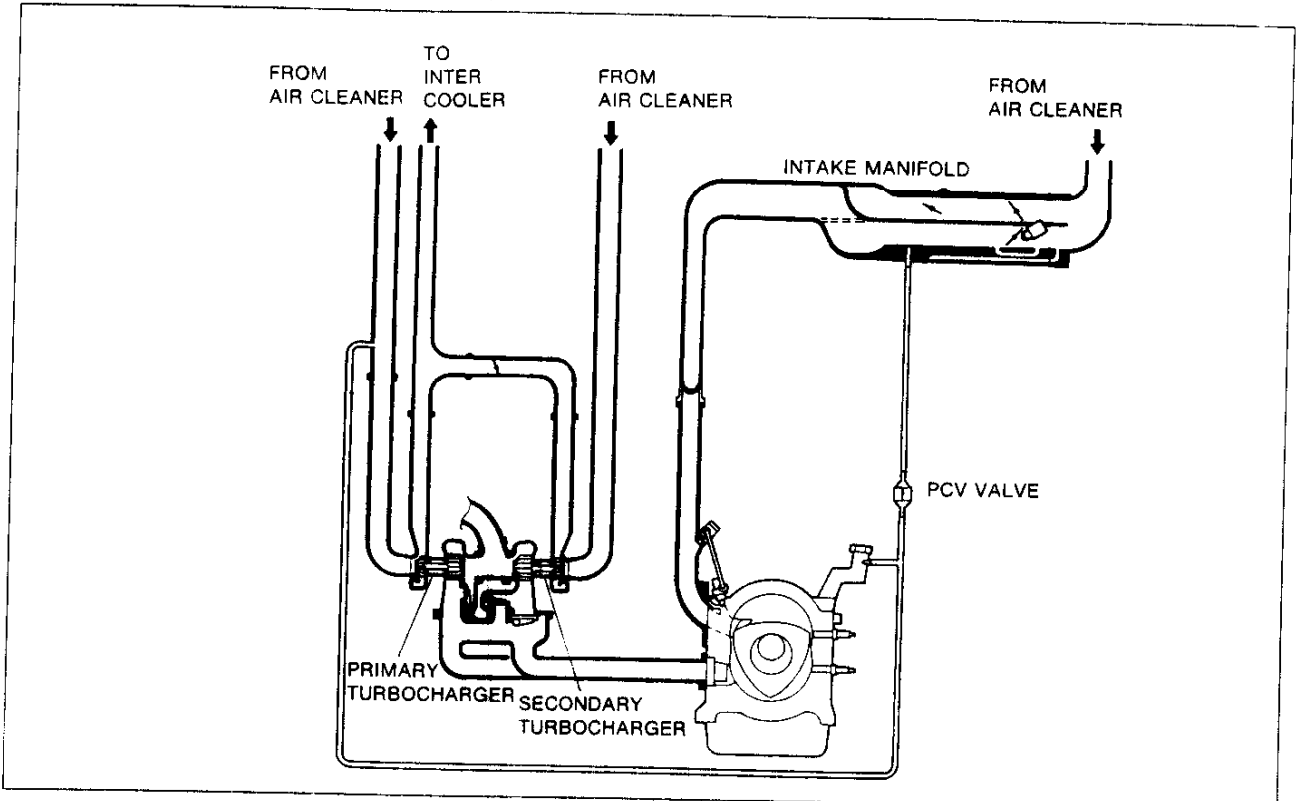

29U0FX-211

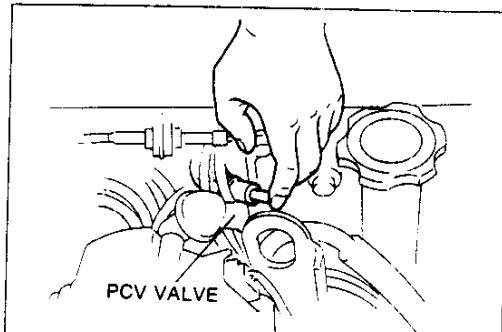

29U0FX-232

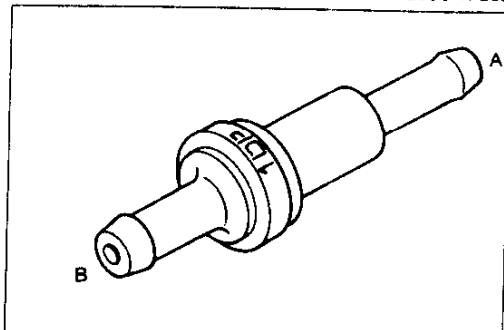

29U0FX-233

PCV VALVE

Inspection

1. Warm up the engine to the normal operating temperature and run it at idle.
2. Disconnect the PCV valve with the ventilation hose.
3. Block the PCV valve opening.
4. Verify that vacuum is felt.
5. Remove the PCV valve.
6. Blow through the valve from port A and verify that air comes out of port B.
7. Blow through the valve from port B and verify that no air comes out of port A.
8. Replace the PCV valve if necessary.

EXHAUST GAS RECIRCULATION (EGR) CONTROL SYSTEM

DESCRIPTION

This system recirculates a small amount of exhaust gas into the intake manifold to reduce the combustion temperature, and reduce NOx emissions.

This system consists of the EGR valve, EGR switch, solenoid valve, ECU and input devices.

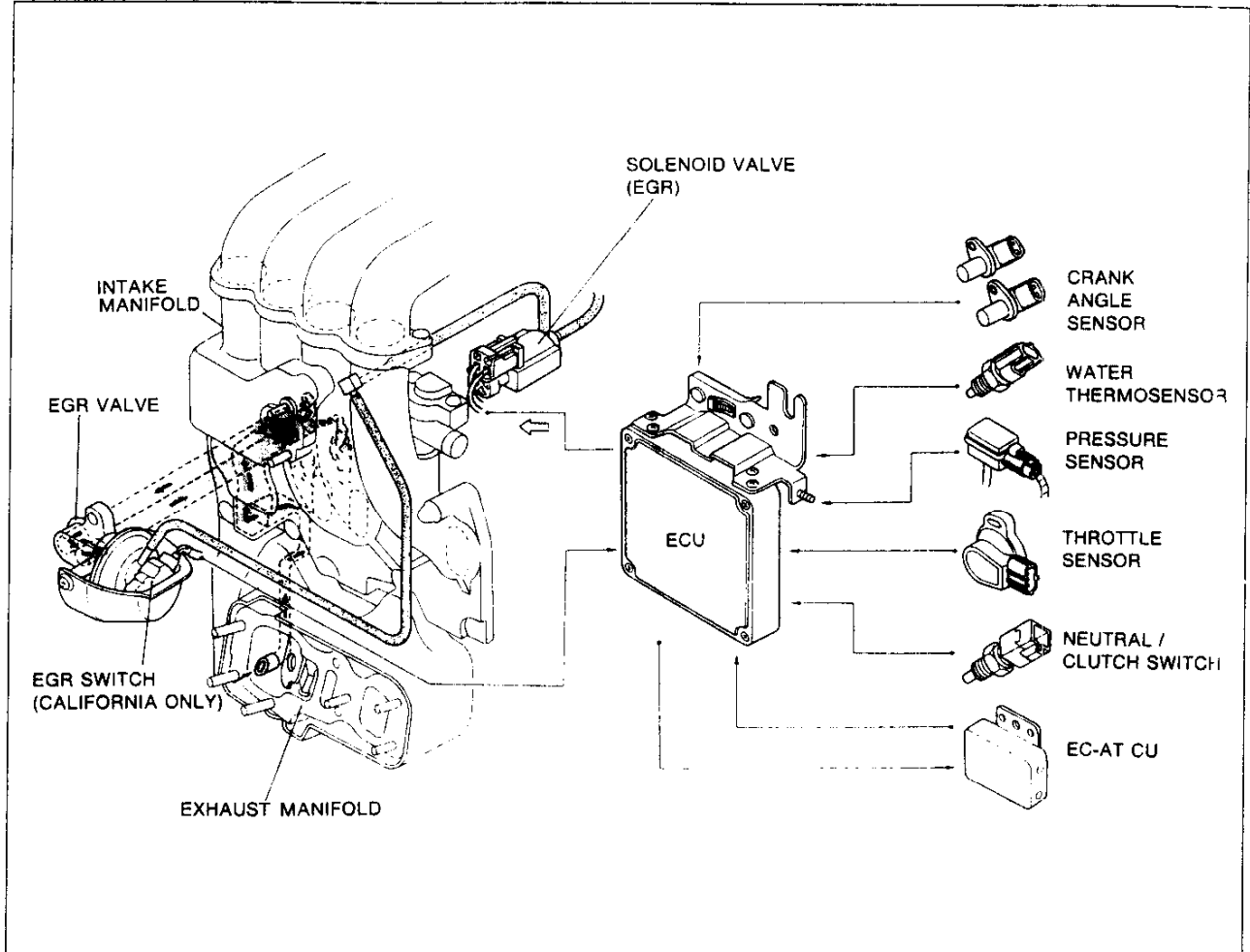

Operation

Cold engine (Engine coolant temperature: below 70°C [158°F])

EGR operation is stopped to improve drivability when the engine is cold.

Warm engine





The ECU controls the solenoid valve to supply EGR gases as described below.

Operating condition	EGR operation	Remark
Idle	Stopped	-
Deceleration		-
High engine speed		Above 3850 rpm
Heavy load		-
Others (Engine speed above 1050 rpm)	Supplied EGR gas	MT 5th gear, AT OD position Above 1700 rpm

F

EXHAUST GAS RECIRCULATION (EGR) CONTROL SYSTEM

PREPARATION SST

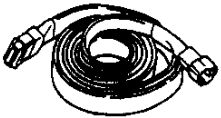
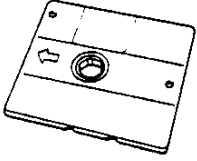
49 F088 001 DT-S1000 Base unit		For inspection of solenoid valve	49 F088 002 Power unit (DC12V)		For inspection of solenoid valve
49 F088 003 Harness Power unit		For inspection of solenoid valve	49 F088 004 Interface adaptor Type-1		For inspection of solenoid valve
49 F088 005 Harness Type-1		For inspection of solenoid valve	49 F088 011 System disk Type-1 (Ver 1.00)		For inspection of solenoid valve

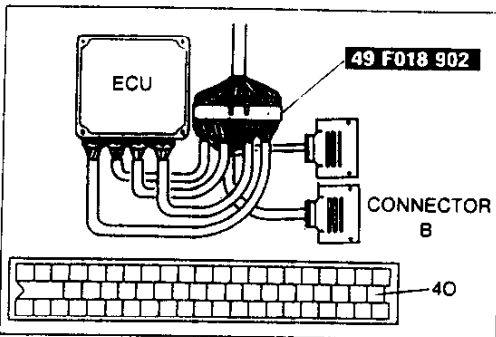

SYSTEM OPERATION

Engine Signal Monitor

1. Connect the **SST** (Engine Signal Monitor Adaptor Harness) to the ECU as shown.
2. Start the engine.
3. Accelerates the engine and verify that ECU terminal 40, voltage V_B while the engine is still cold.
4. Warm up the engine to normal operating temperature and run it at idle.
5. Short the ECU terminal 40 and verify that the engine runs roughly or stalls at idle.

DT-S1000

1. Connect the **SSTs** (DT-S1000 and Harness) to the diagnosis connector as shown.
2. Start the engine.
3. Accelerate the engine and verify that the EGR solenoid valve OFF while engine is still cold.
4. Warm up the engine to normal operating temperature and run it at idle.
5. Select simulation check and verify that the engine runs roughly or stalls at idle when solenoid valve ON.

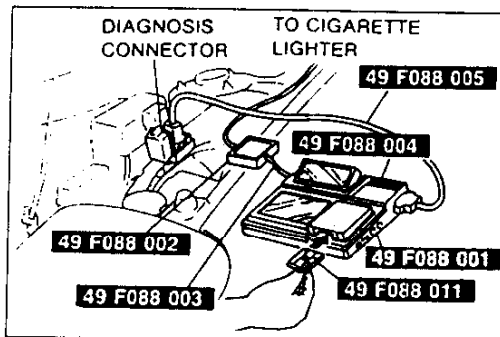

EGR VALVE

Removal / Installation

1. Remove the intake air system component parts. (Refer to page F-76)
2. Remove in the order shown in figure.
3. Install in the reverse order of removal.

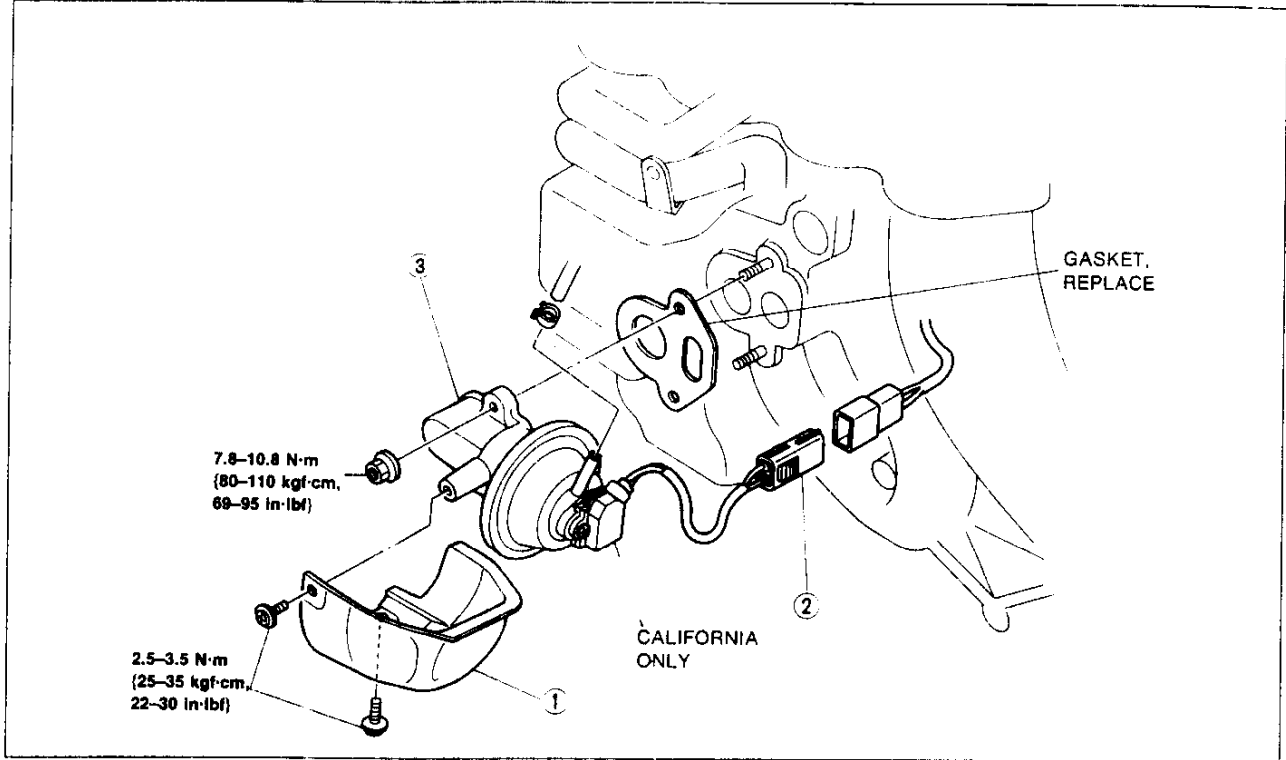

1. Insulator
2. Connector

3. EGR valve
Inspection below

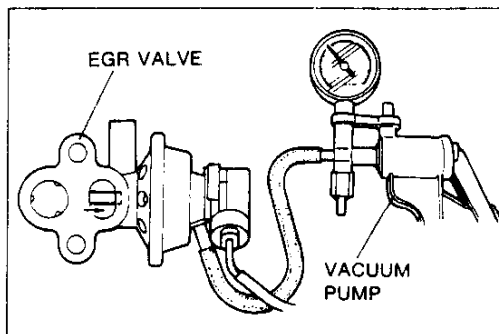

Inspection

1. Connect a vacuum pump as shown and apply vacuum.
2. Verify that the EGR valve moves at more than the specified vacuum.

Specification: 11-15.3 kPa (85-115 mmHg, 3.3-4.5 inHg)

3. If not as specified, replace EGR valve.

EGR SWITCH (CALIFORNIA ONLY)

Inspection

1. Remove the EGR valve (Refer to above)
2. Connect a vacuum pump as show and apply vacuum.
3. Verify that the EGR switch ON at more than the specified vacuum.

Specification: 11-15.3 kPa (85-115 mmHg, 3.3-4.5 inHg)

4. If not as specified, replace EGR valve.

SOLENOID VALVE (EGR)

Inspection

(Refer to page F-190)

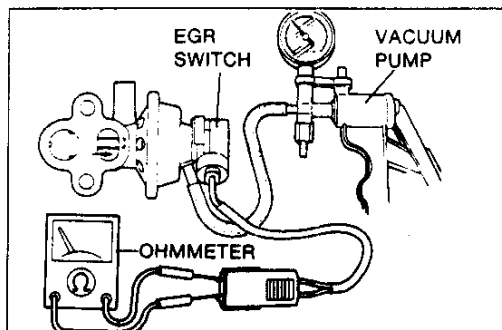

F

CATALYTIC CONVERTER SYSTEM

CATALYTIC CONVERTER SYSTEM

DESCRIPTION

Two beta three-way catalytic converters are used to reduce CO, HC, and NOx emissions. For efficient operation, the front converter is placed close to the exhaust manifold so that it will heat up quickly and purify exhaust gas efficiently when engine runs at idle. The front converter also protects the main converter from damaged by acting as a phosphorus and lead filter.

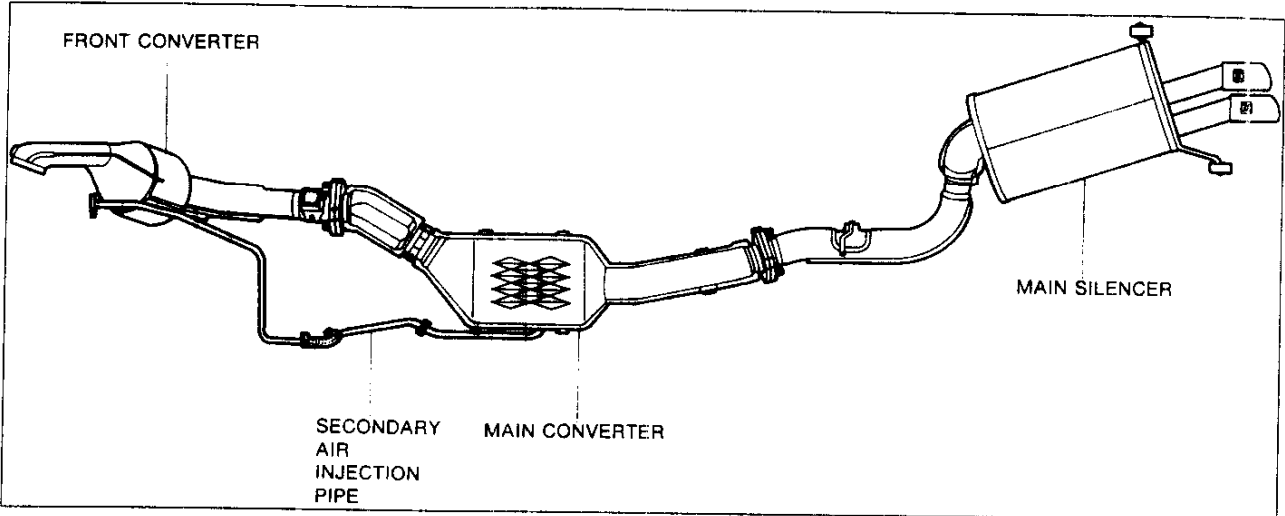

The catalytic converters reduce CO and HC, emissions through oxidization and NOx emissions by chemical reaction.

Catalytic converter	Type
Front converter	Metal
Main converter	Monolythic

Operation

- (1) Before the engine is warmed up, when large amounts of CO and HC are ceated, the converter is supplied port air and uses both the first and second stages as the oxidization catalyst.
- (2) In the normal driving range, the converter is supplied split air and uses the first stage as the ternary catalyst and second stage as the oxidization catalyst.
- (3) During high-speed driving, an additional air to the converter is cut off, and the first and second stages are used the ternary catalyst.

	First stage	Second stage	Remark
Port air	Oxidation	Oxidation	Low-speed range, Deceleration range
Split air	Ternary	Oxidation	Cruising range
Air cut	Ternary	Ternary	High-speed range

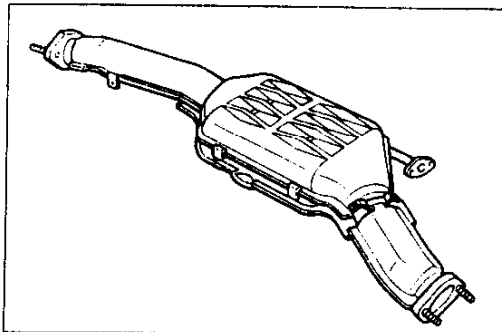

CATALYTIC CONVERTER (FRONT CONVERTER AND MAIN CONVERTER)

Inspection

1. Check the catalytic converter for deterioration or clogging.
2. Check the insulation covers welded onto the catalytic converter for damage.

Note

- If the insulation cover is touching the catalytic converter housing, excessive heat at the floor will occur.

EVAPORATIVE EMISSION CONTROL SYSTEM

DESCRIPTION

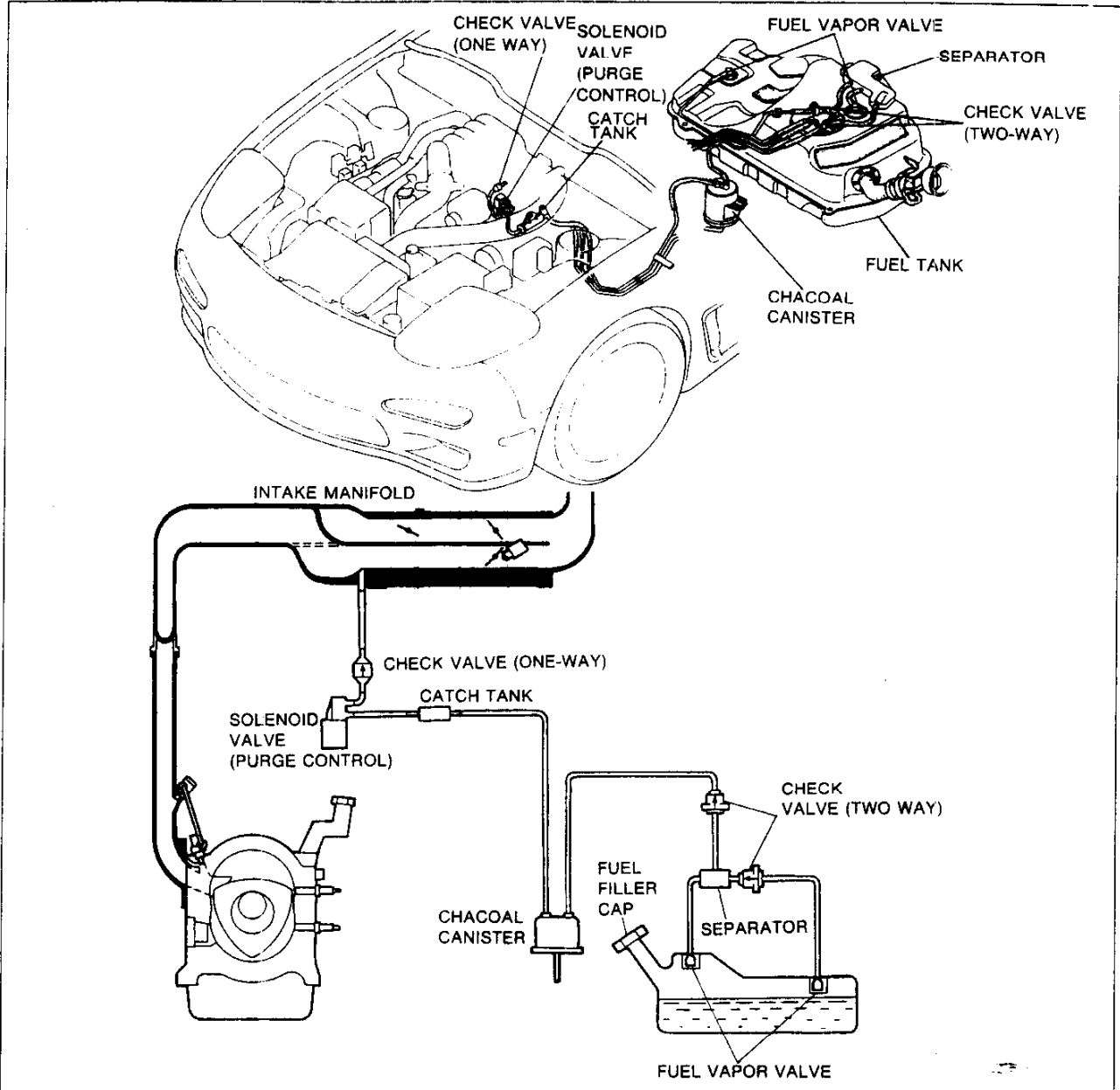

The evaporative emission control system temporarily stores in the canister the evaporative fumes generated in the fuel tank. The stored gas is then passed into the air intake system for combustion when the engine is running. This operation prevents evaporative fumes from flowing out to the atmosphere.

Sending a large volume of evaporative fumes at one time into the air intake system deteriorates the air/fuel ratio; thus, the ECU uses the solenoid valve (purge control) to regulate this volume.

Operation**With engine stopped and no load applied**

The evaporative fumes from the fuel tank are absorbed by the charcoal canister.





With engine running and load applied

The evaporative fumes absorbed by the charcoal canister are drawn into the engine via the solenoid valve (purge control). The volume of fumes drawn depends on engine conditions.

F

EVAPORATIVE EMISSION CONTROL SYSTEM

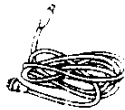
PREPARATION SST

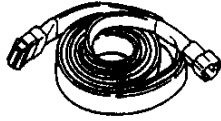
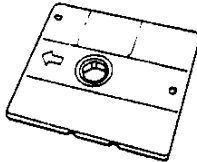
49 F088 001 DT-S1000 Base unit		For inspection of solenoid valve and relay	49 F088 002 Power unit (DC12V)		For inspection of solenoid valve
49 F088 003 Harness Power unit		For inspection of solenoid valve	49 F088 004 Interface adaptor Type-1		For inspection of solenoid valve
49 F088 005 Harness Type-1		For inspection of solenoid valve	49 F088 011 System disk Type-1 (Ver 1.00)		For inspection of solenoid valve

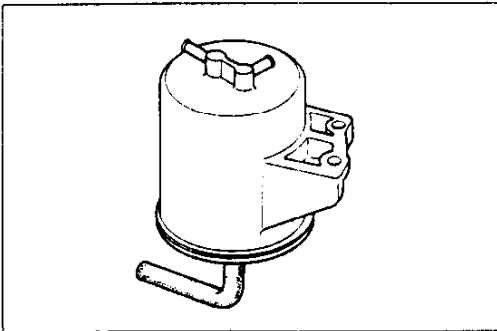
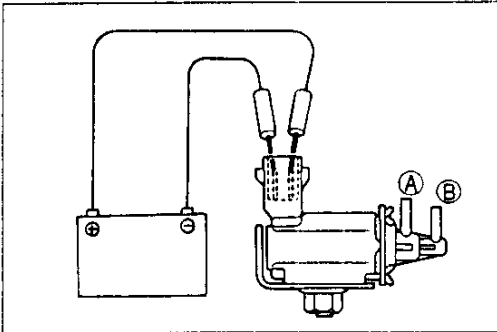
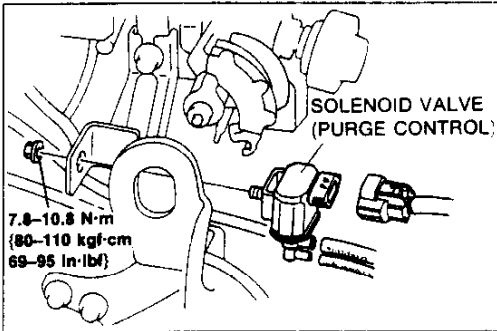
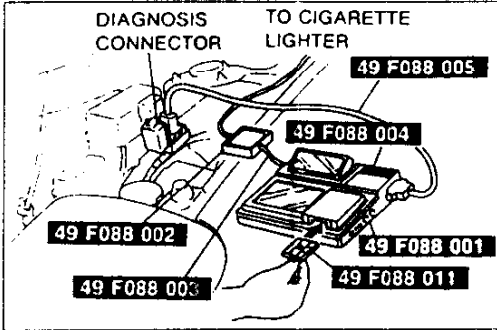
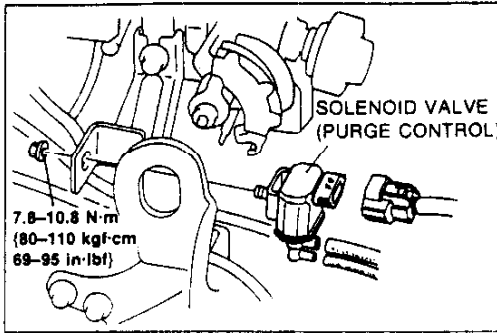

SYSTEM OPERATION

1. Warm up the engine to normal operating temperature and run it at idle.
2. Disconnect the vacuum hose from the solenoid valve (purge control) as shown in the figure, and verify that no vacuum is felt at the solenoid valve.
3. If not as specified, check the solenoid valve.

DT-S1000

1. Connect the **SSTs** (DT-S1000 and Harness) to the diagnosis connector.
2. Warm up the engine to normal operating temperature and run it idle.
3. Select simulation check and verify that the solenoid valve operation sound is heard when solenoid valve ON.
4. If operation sound is not heard, check the following condition below.
 - Vacuum tube
Inspect vacuum line fitting, connections and components for leaks. (Refer to page F-10)
 - Evaporative hose
Inspect evaporative line fitting, connection and components for leaks.

SOLENOID VALVE (PURGE CONTROL)

Removal / Installation

1. Disconnect the vacuum hoses and connector from solenoid valve.
2. Remove the mounting nuts and solenoid valve.
3. Install in the reverse order of removal.

Inspection

1. Disconnect the vacuum hoses from the solenoid valve.
2. Blow into the valve and verify that no air flows through it.
3. Disconnect the solenoid valve connector and apply battery voltage as shown in the figure.
4. Blow into the valve and verify that air flows through it.
5. If not as specified, measure the solenoid valve resistance with an ohmmeter.

Resistance: 30-34 Ω (20°C [68°F])

6. If not as specified, replace the solenoid valve.

CHARCOAL CANISTER

Inspection

Visually check for damage and replace the charcoal canister if necessary.

F

EVAPORATIVE EMISSION CONTROL SYSTEM

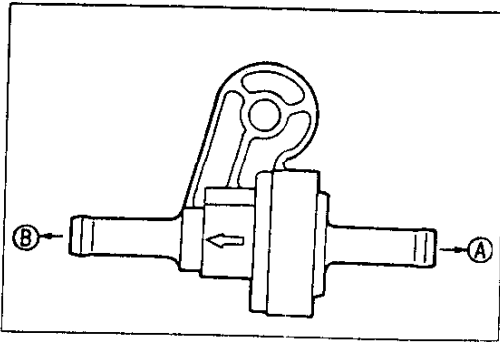

CHECK VALVE (TWO-WAY)

Inspection

1. Remove the check valve.
2. Check the operation of the check valve by using a vacuum pump.

Apply approx. 5 kPa {37 mmHg, 1.46 inHg} vacuum at port A	Air flow
Apply approx. 6 kPa {44 mmHg, 1.73 inHg} vacuum at port B	Air flow

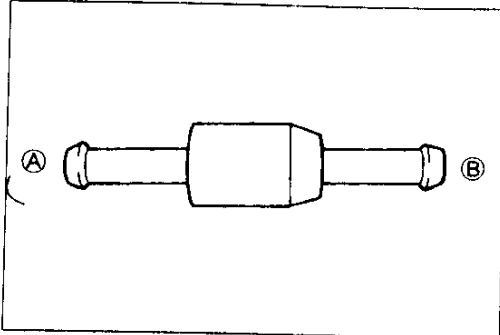

CHECK VALVE (ONE-WAY)

Inspection

1. Remove the check valve.
2. Blow through the check valve from port A, and check that the air flows from port B
3. Blow through the check valve from port B, and check there is no flow.

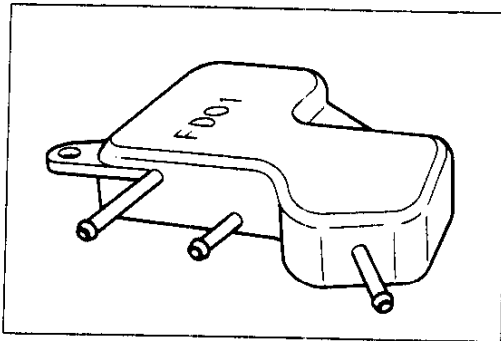

SEPARATOR

Inspection

Visually check for damage and replace the separator if necessary.

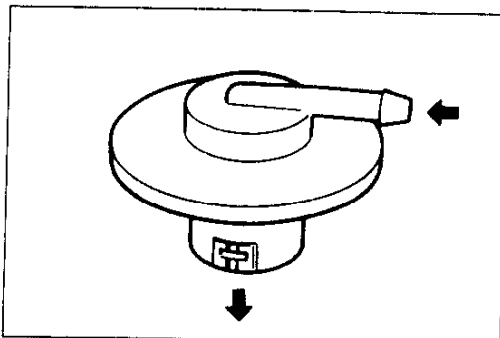

FUEL VAPOR VALVE

Inspection

1. Remove the valve.
2. Blow through the valve and verify that air flows in the direction shown.

29U0FX-242

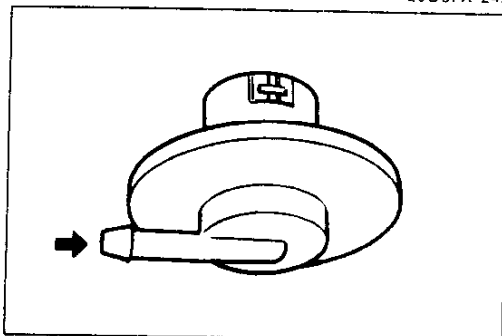

3. Turn the valve over and blow through the valve. Verify that no air flows.
4. Replace the valve if necessary.

29U0FX-243

DECELERATION CONTROL SYSTEM

DESCRIPTION

- Dash pot : To prevent the throttle valves from closing suddenly.
- Solenoid valve (ISC) : To prevent afterburn, air is supplied to intake manifold during deceleration.
- Fuel cut control : To improve the fuel economy and to prevent engine bucking during deceleration.
- Air bypass valve : Bypasses compressed air from after the turbocharger to air cleaner during deceleration to prevent noise.

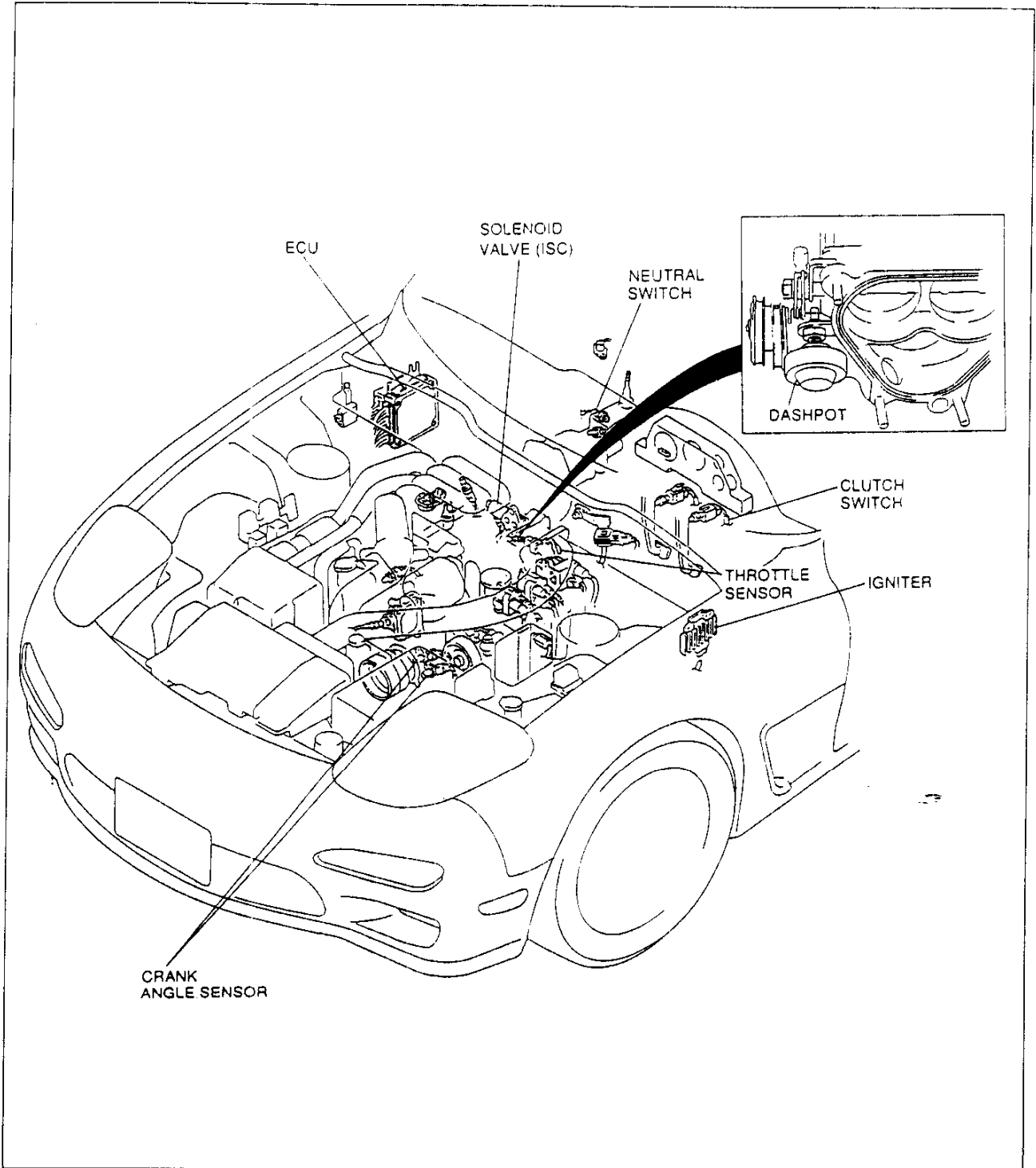

F

DECELERATION CONTROL SYSTEM

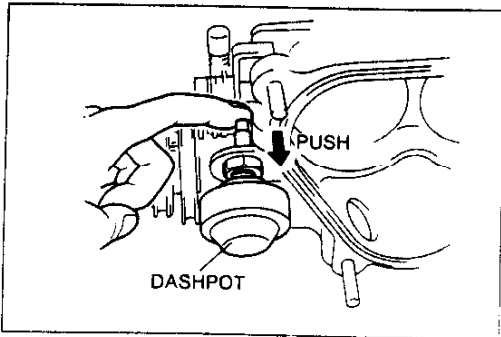

DASHPOT

Inspection

1. Open the throttle valve fully, then push the dash pot rod with a finger and verify that the rod goes in slowly.
2. Release the rod and verify that it comes out quickly.
3. Replace it, if necessary.

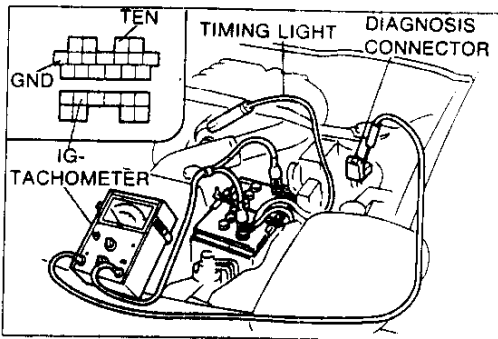

Adjustment

1. Warm up the engine to the normal operating temperature and run it idle.
2. Verify that the fast idle cam separates.
3. Turn all electrical loads OFF.
4. Connect a tachometer to the diagnosis connector terminal IG-.
5. Open the throttle valve until the dash pot rod separates from the lever.
6. Check the engine speed when the dash pot rod touches to the lever.

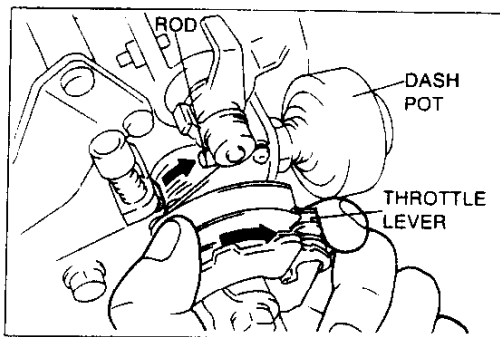

Engine speed: 2600–3000 {2800 ± 200} rpm

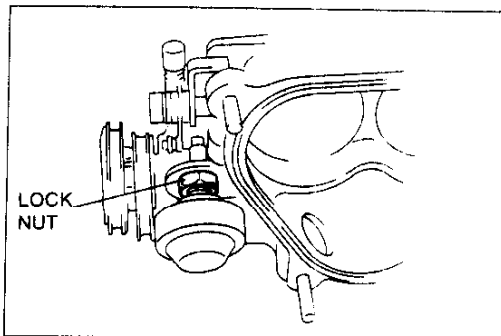

7. Loosen the lock nut and adjust by turning the dash pot, if necessary.

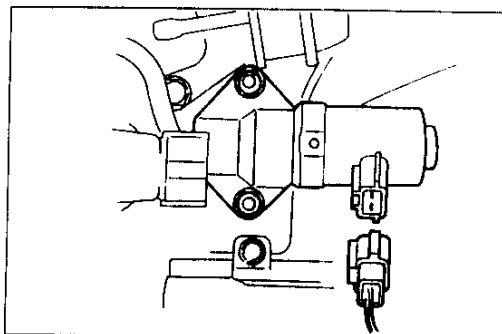

ANTI AFTERBURN CONTROL

System operation

1. Start the engine and run it at idle.
2. Disconnect solenoid valve (ISC) connector.
3. Increase the engine speed to over 4,000 rpm then decrease the engine speed rapidly.
4. Verify that the engine speed decrease roughly at 1500–1000 rpm.

ELECTRICAL LOAD (E/L) CONTROL SYSTEM

DESCRIPTION

The engine speed increases when any of the following switches are ON.

- Rear defroster switch
- Headlight switch
- Blower motor switch 3rd or 4th position.
- Water thermo switch for fan motor.

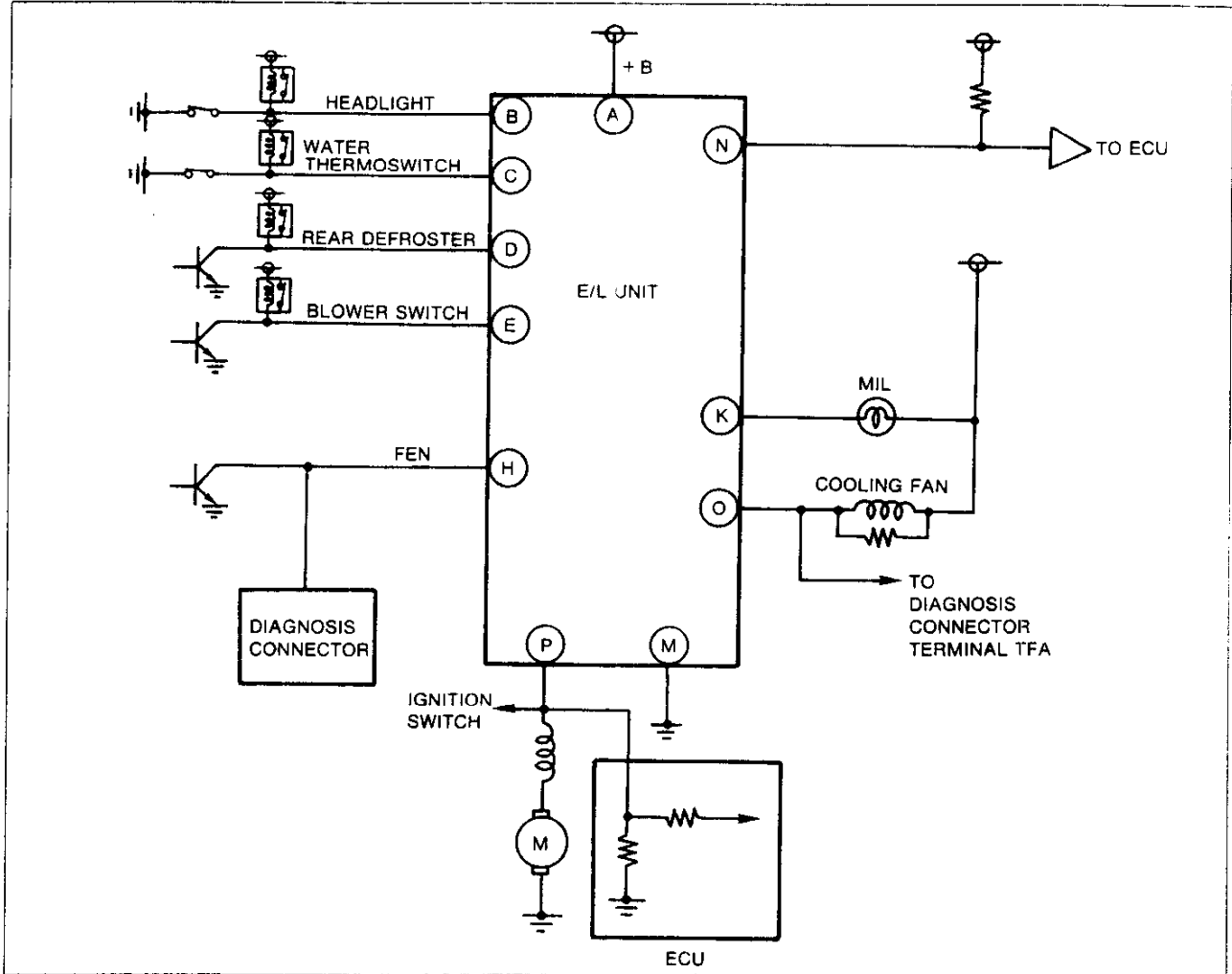

PREPARATION

SST

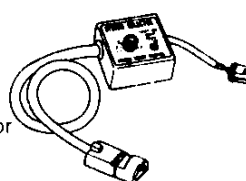
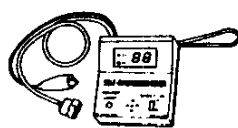
<p>49 B019 9A0</p>  <p>System Selector</p>	<p>For diagnosis</p>	<p>49 H018 9A1</p>  <p>Self-Diagnosis Checker</p>	<p>For diagnosis</p>
---	----------------------	---	----------------------

F

ELECTRICAL LOAD (E/L) CONTROL SYSTEM

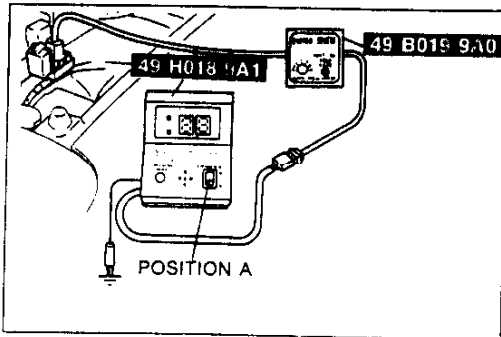

SYSTEM OPERATION

1. Connect the **SST** (System selector) to the diagnosis connector.
2. Set switch A to position 1 and TEST SW to SELF-TEST.
3. Connect the **SST** (Self-Diagnosis Checker) to the System Selector and a ground.
4. Set the select switch to position A.
5. Turn ignition switch ON.
6. Check if the monitor lamp illuminates when each switch is made to function. (Refer to page F-67)

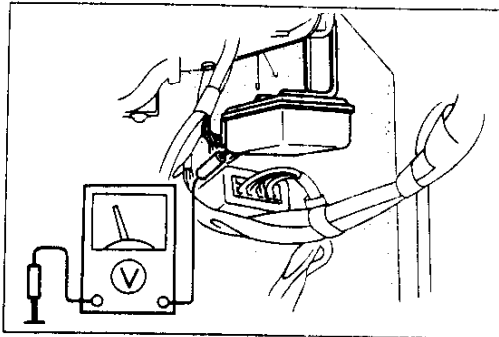

Inspection

1. Remove the E/L unit. (Refer to page F-150)
2. Connect the E/L unit connector.
3. Measure the voltage at each terminal by using a voltmeter.
4. If any E/L unit terminal voltage is incorrect, check the input or output device and related wiring harness. If they are normal, replace the E/L unit.

Terminal voltage

Terminal	Input	Output	Connected to	Test condition	Correct voltage	Remark
A	-	-	Main relay	Ignition switch ON	V_B	-
B	○		TNS relay	Position light ON	V_B	-
				Position light OFF	0V	
C	○		Water thermoswitch	Engine coolant temperature below 108°C	V_B	Ignition switch ON
				Engine coolant temperature above 108°C {221°F}	0V	
D	○		Rear window defroster ready	Rear window defroster OFF	V_B	Ignition switch ON
				Rear window defroster ON	Below 1.0V	
E	○		Blower motor relay	Blower switch 3rd or 4th position	Below 1.0V	Ignition switch ON
				Blower switch 1st or 2nd position	V_B	
F	-	-	-	-	-	-
G	-	-	-	-	-	-
H		○	Self-Diagnosis checker Diagnosis connector (FEN)	Buzzer sounded for 3 sec. after ignition switch OFF → ON	Below 2.5V	<ul style="list-style-type: none"> • With Self-Diagnosis checker and system Selector • With System Selector test switch at SELF TEST
				Buzzer not sounded for after 3 sec.	V_B	
				Buzzer sounded	Below 2.5V	
				Buzzer not sounded	V_B	
I	-	-	-	-	-	-
J	-	-	-	-	-	-
K		○	Malfunction indicator lamp (MIL)	Lamp illuminated for 3 sec. after ignition switch ON	Below 2.5V	With system selector test switch at SELF TEST
				Lamp not illuminated after 3 sec.	V_B	
				Lamp illuminated	Below 2.5V	
				Lamp not illuminated	V_B	
L	-	-	-	-	-	-
M	-	-	Ground	Constant	0V	-
N		○	ECU	Electrical load ON	Below 2.5V	Ignition switch ON
				Electrical load OFF	V_B	
O		○	Cooling fan relay	Engine coolant temperature below 108°C	Below 2.5V	Ignition switch ON
				Engine coolant temperature above 108°C	V_B	
P	○		Ignition switch	While cranking	-	-
				Ignition switch ON	Below 1.0V	

DOUBLE THROTTLE CONTROL SYSTEM

DESCRIPTION

The response delay of the pressure sensor followed mounted by rapid acceleration temporarily causes a lean fuel mixture. The double throttle control system prevents hesitation caused by this lean fuel mixture by slightly delaying the opening of the double throttle valve after the secondary throttle valve.

The double throttle valve is controlled by the ECU through the solenoid valve.

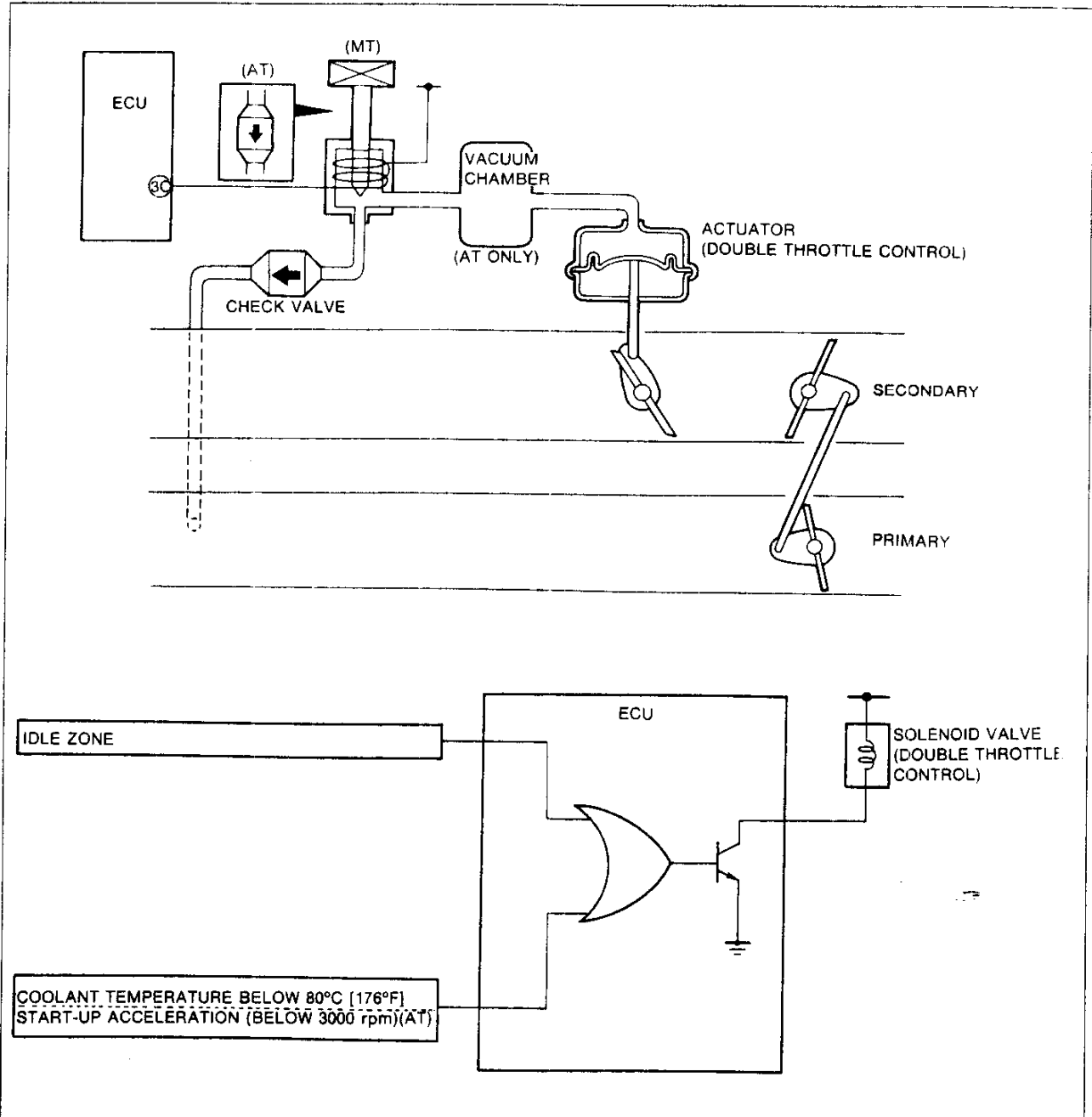





OPERATION

When one or more of the above conditions are met, the ECU turns the solenoid valve ON, applies vacuum to the actuator (double throttle control), and closes the double throttle valve.

F

DOUBLE THROTTLE CONTROL SYSTEM

PREPARATION SST

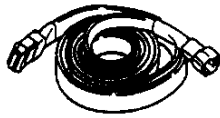
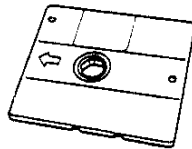
49 F088 001 DT-S1000 Base unit		For inspection of solenoid valve and relay	49 F088 002 Power unit (DC 12V)		For inspection of solenoid valve
49 F088 003 Harness Power unit		For inspection of solenoid valve	49 F088 004 Interface adapter Type-1		For inspection of solenoid valve
49 F088 005 Harness Type-1		For inspection of solenoid valve	49 F088 011 System disk Type-1 (Ver.1.00)		For inspection of solenoid valve

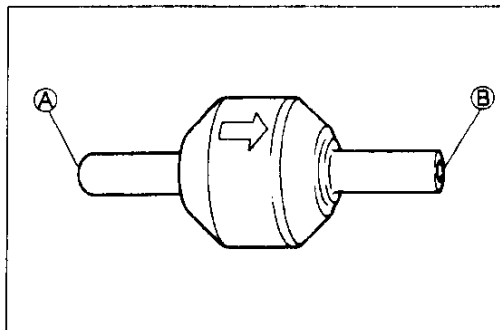
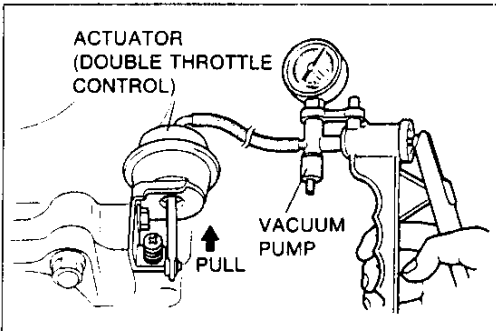
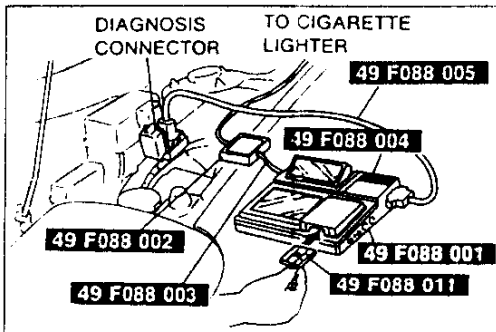
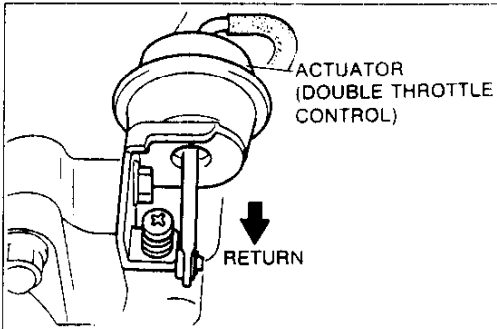
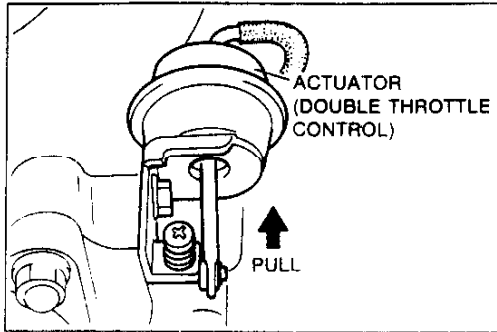

SYSTEM OPERATION

1. Start the engine and verify that the actuator (Double throttle control) rod is pulled into actuator while engine is cold.
2. If the actuator rod is not pulled, check the following condition below.
 - Vacuum tube
Inspect vacuum line fitting, connections and components for leaks. (Refer to page F-10.)
 - Vacuum chamber
Visually check for dogging damage or crack.
 - Actuator
Inspection. (Refer to below.)
 - Solenoid valve (Double throttle control)
Inspection. (Refer to page F-190.)
 - Water thermosensor
Inspection. (Refer to page F-183.)
3. Verify that the actuator rod is returned, when warm up the engine to normal operating temperature.
4. If the actuator rod is not return, check the following condition below.
 - Solenoid valve (Double throttle control)
Inspection. (Refer to page F-190.)
 - Water thermosensor
Inspection. (Refer to page F-183.)

DT-S1000

1. Connect the **SSTs** (DT-S1000 and Harness)
2. Start the engine and run it idle.
3. Select the simulation check (Double throttle control) and verify that the actuator rod is moved when solenoid valve on and OFF
4. If actuator rod is not moved check the condition above.

ACTUATOR (DOUBLE THROTTLE CONTROL)

Inspection

1. Disconnect vacuum hose
2. Connect a vacuum pump and verify that actuator rod is pulled into actuator when apply the vacuum more than 22.0-28.7 kPa {165-215 mmHg, 6.5-8.5 inHg}
3. If not as specified, replace the actuator

Removal / Installation

(Refer to page F-78)

CHECK VALVE

Inspection

1. Remove the check valve.
2. Blow through A and check that air flows from B.
3. Blow through B and check that air does not flow from A.

A/C CUT-OFF SYSTEM

DESCRIPTION

An A/C cut off system is used to improve idle smoothness immediately after starting the engine and to improve acceleration performance.

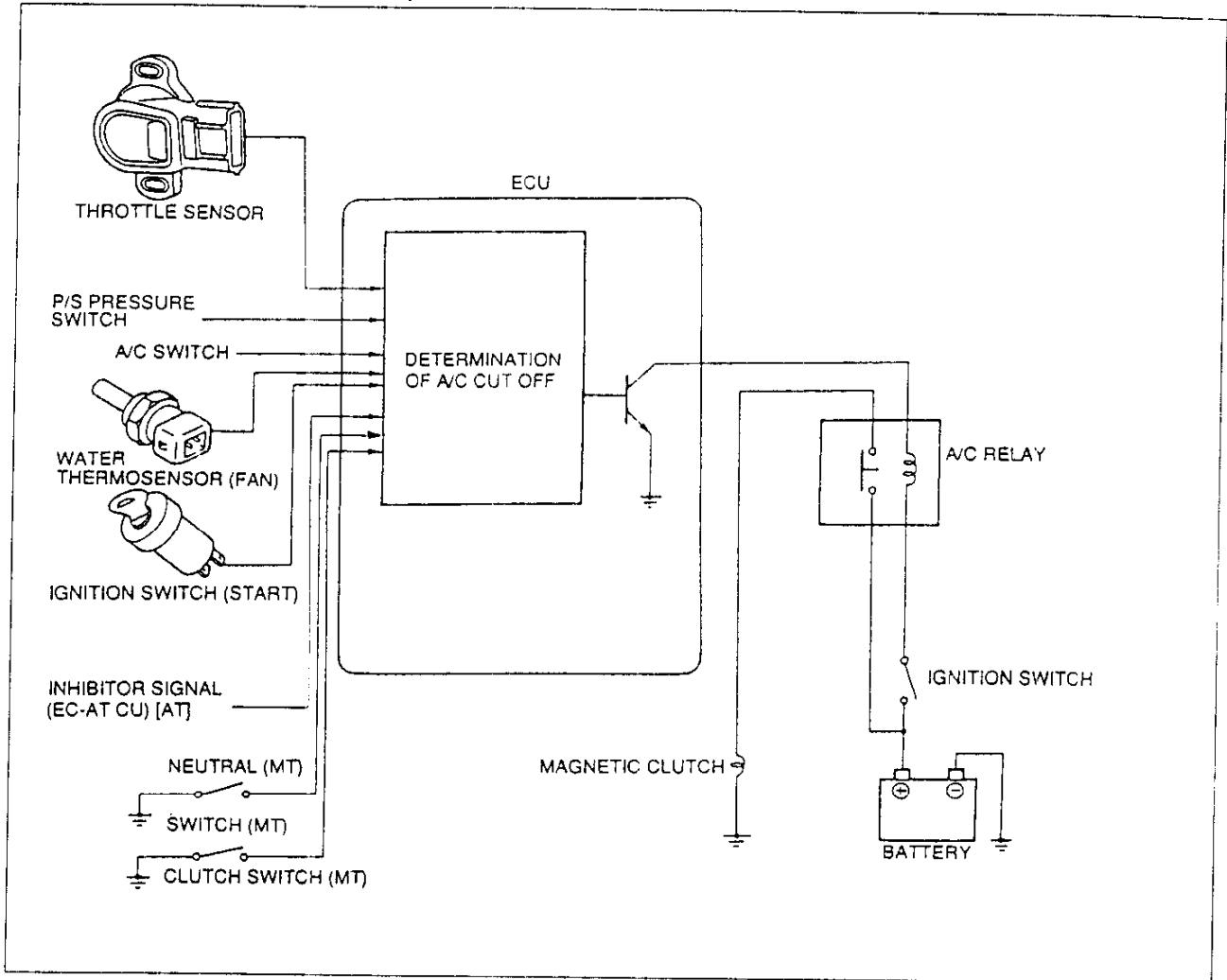





16EOF2-19

Operation

Engine condition	Purpose	Cut off period
After engine started	Improved idle	Approx. 8 sec.
Throttle valve fully open	Improved drivability	Approx. 7 sec.
Water temperature over 117°C {243°F}	Prevent engine from over heating	Water temperature under 115°C {239°F}

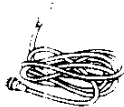
PREPARATION SST

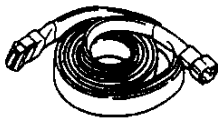
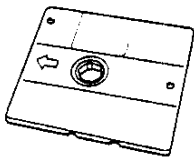
<p>49 F088 001</p> <p>DT-S1000 Base unit</p> 	<p>For inspection of solenoid valve and relay</p>	<p>49 F088 002</p> <p>Power unit (DC 12V)</p> 	<p>For inspection of solenoid valve</p>
<p>49 F088 003</p> <p>Harness Power unit</p> 	<p>For inspection of solenoid valve</p>	<p>49 F088 004</p> <p>Interface adapter Type-1</p> 	<p>For inspection of solenoid valve</p>
<p>49 F088 005</p> <p>Harness Type-1</p> 	<p>For inspection of solenoid valve</p>	<p>49 F088 011</p> <p>System disk Type-1 (Ver.1.00)</p> 	<p>For inspection of solenoid valve</p>

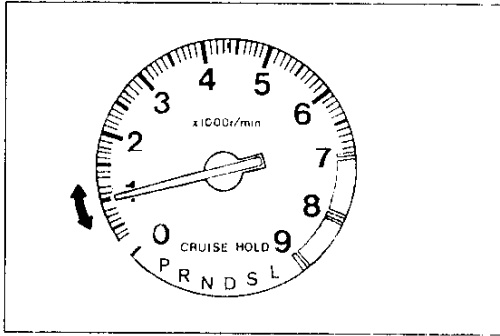

SYSTEM OPERATION

1. Start the engine and let it idle.
2. Turn the A/C and blower switches ON, and verify that no engine speed decrease.
3. Turn the blower switch OFF and verify that no engine speed increase.
4. If not as specified, check for cause.
 - Solenoid valve (ISC) inspection (Refer to page F-82)
 - A/C signal (ECU terminal 1E) inspection (Refer to page F-152)

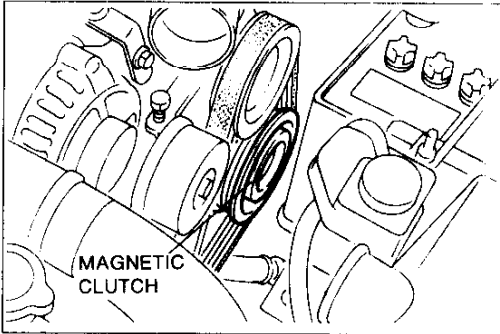

**Inspection
Acceleration cut-off**

1. Turn ignition switch ON.
2. Shift transmission into gear (MT) or shift into D range (AT)
3. Turn the A/C and blower switches ON
4. Open the throttle valve fully and verify that the magnetic clutch disengage (click is heard) then reengages after **approx 5 seconds**.

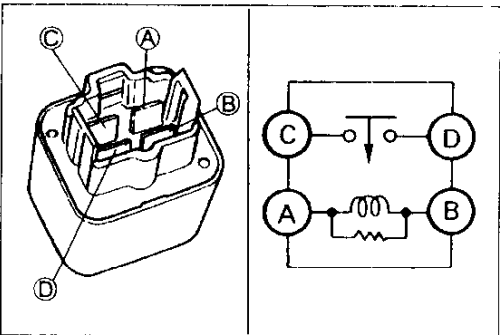

**A/C relay
Continuity inspection**

Check continuity between the terminals with ohmmeter

Terminal A-B	Terminal C-D
Apply V_B	Yes
Not Apply V_B	No

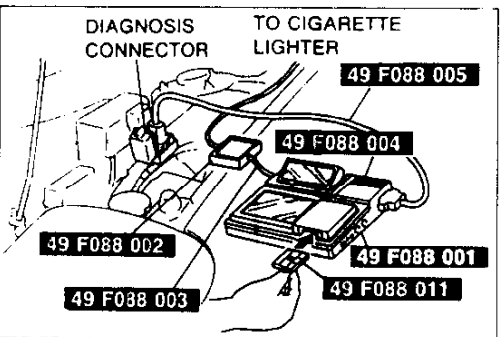

DT-S1000

1. Connect the DT-S1000 to the diagnosis connector.
2. Select simulation check.
3. Turn ignition switch ON.

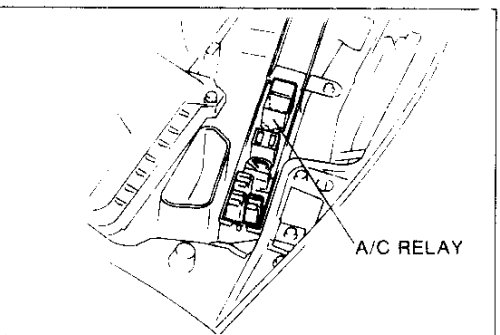

4. Verify that the A/C relay operation sound is heard.
5. If no sound is heard check the continuity of A/C Relay.

DECHOKE CONTROL SYSTEM

DESCRIPTION

To facilitate starting the engine if the spark plugs become fouled, such as when the engine is flooded, fuel injection is cut off the throttle valve is held wide open while cranking the engine. This allows the spark plugs to dry and purges excess fuel from the cylinders.

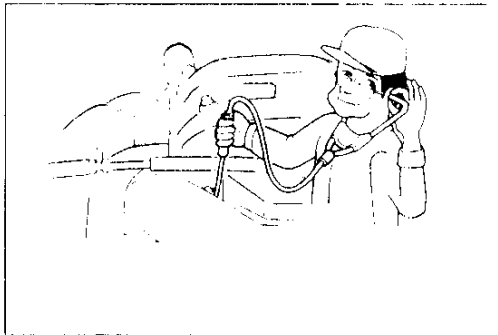

SYSTEM OPERATION

1. Verify that the engine will not start and no operational sound of primary injector with a serewdriver or a soundscope when cranked at normal speed with the throttle fully open.
2. If the engine starts, and operational sound of primary injector is heard, inspect the throttle sensor. (Refer to page F-182) and the ECU terminal 1C voltage. (Refer to page F-152.)

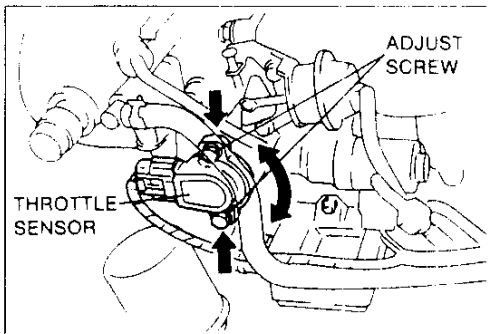

F

ELECTRICAL COOLING FAN CONTROL SYSTEM

ELECTRICAL COOLING FAN CONTROL SYSTEM

DESCRIPTION



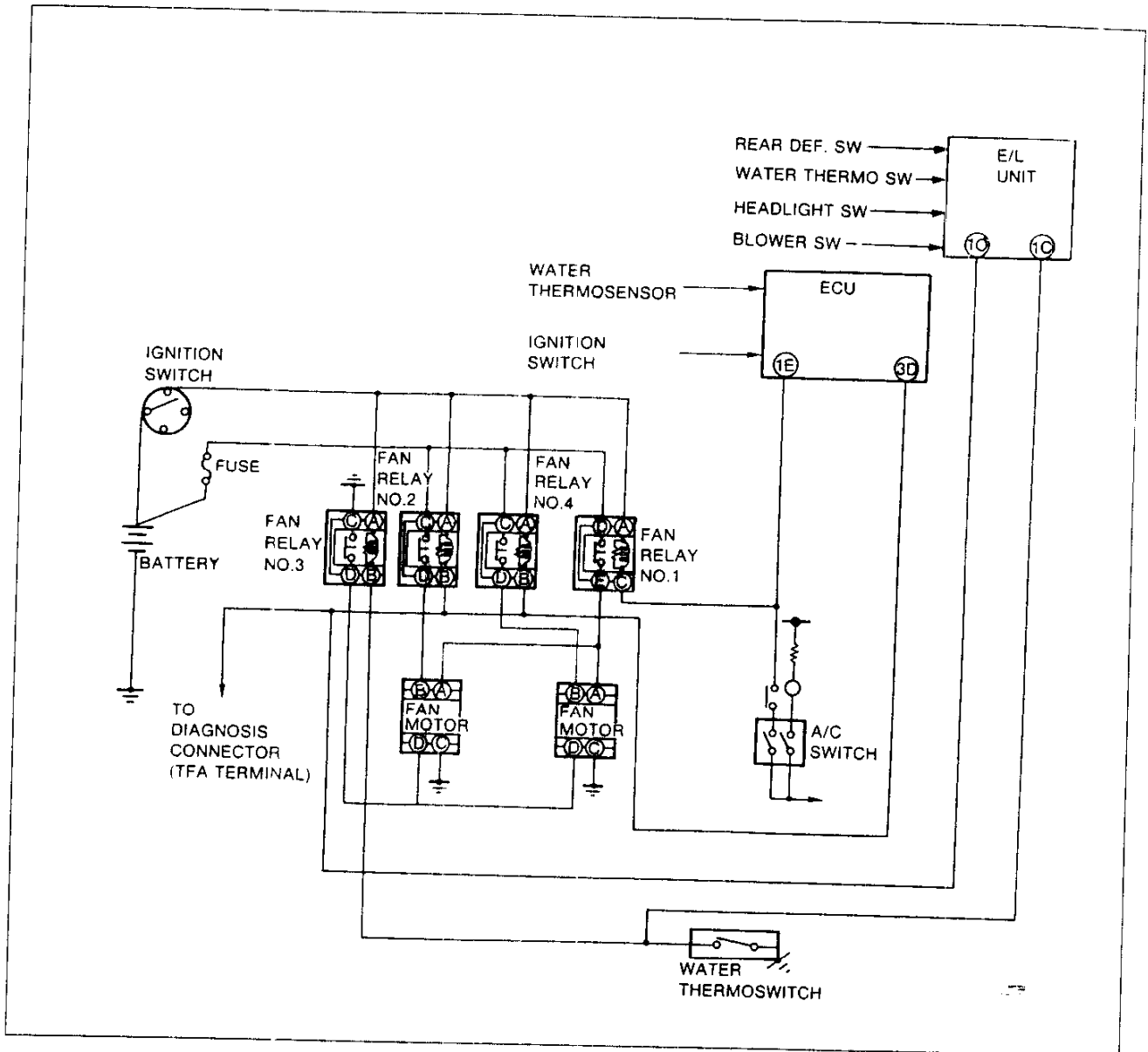



To improve idle smoothness and engine reliability, the Electrical cooling fan control system controls the electrical fan speed by ECU. This system consist of the cooling fan, fan relays, ECU, and input devices.



Operation

Engine condition (No electrical load)	A/C operation	Fan relay No.1	Fan relay No.2	Fan relay No.3	Fan relay No.4	Cooling fan operation
Coolant temperature below 105°C {221°F}	OFF	OFF	OFF	OFF	OFF	OFF
	ON	ON	ON	OFF	ON	LOW
Coolant temperature {221-226°F} 105-108°C	OFF	OFF	ON	OFF	ON	LOW
	ON	ON	ON	OFF	ON	MIDDLE
Coolant temperature above 108°C {226°F} (Water thermo switch ON)	OFF	OFF	ON	ON	ON	MIDDLE
	ON	ON	ON	ON	ON	HIGH
Water thermosensor malfunction	-	OFF	ON	OFF	ON	LOW
TFA terminal ground	-	OFF	ON	OFF	ON	LOW

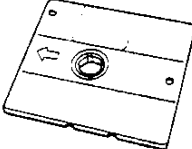
**PREPARATION
SST**

<p>49 F088 001 DT-S1000 Base unit</p> 	<p>For inspection of solenoid valve and relay</p>	<p>49 F088 002 Power unit (DC 12V)</p> 	<p>For inspection of solenoid valve</p>
<p>49 F088 003 Harness Power unit</p> 	<p>For inspection of solenoid valve</p>	<p>49 F088 004 Interface adapter Type-1</p> 	<p>For inspection of solenoid valve</p>
<p>49 F088 005 Harness Type-1</p> 	<p>For inspection of solenoid valve</p>	<p>49 F088 011 System disk Type-1 (Ver. 1.00)</p> 	<p>For inspection of solenoid valve</p>
<p>49 F018 902 Adaptor harness</p> 	<p>For inspection of solenoid valve</p>		

F

ELECTRICAL COOLING FAN CONTROL SYSTEM

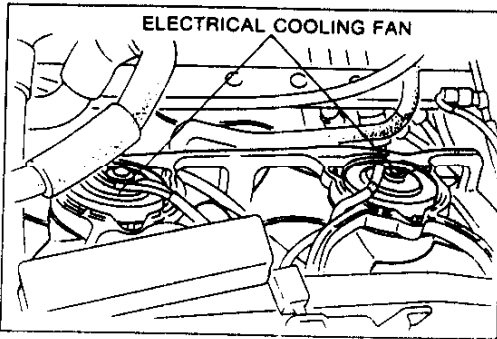

SYSTEM OPERATION

1. Connect the diagnosis connector terminals TFA and GND with a jumper wire.
2. Turn ignition switch ON.
3. Verify that electrical cooling fans operate.

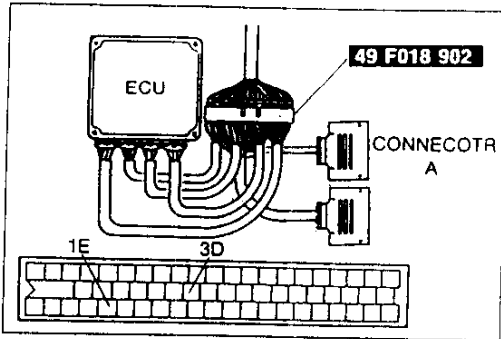

Inspection

1. Connect the **SST** (Engine Signal Monitor Adaptor Harness) to the ECU
2. Turn ignition switch ON.
3. Short the ECU terminals and verify that the cooling fan operate as following condition below.

Terminal	Fan relay
3D	24
1E	1

4. If not as specified, check the harness and relays.

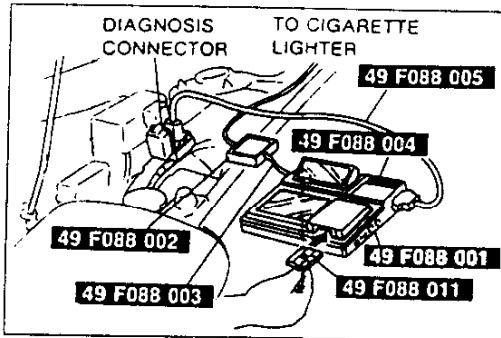
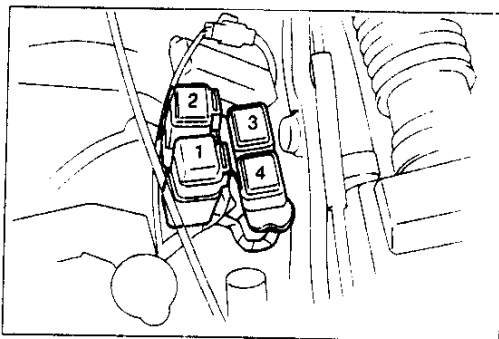

DT-S1000

1. Connect the **SSTs** (DT-S1000 and Harness) to the diagnosis connector.
2. Turn ignition switch ON.
3. Select the simulation check (fan relay) and verify that the cooling fan operate.

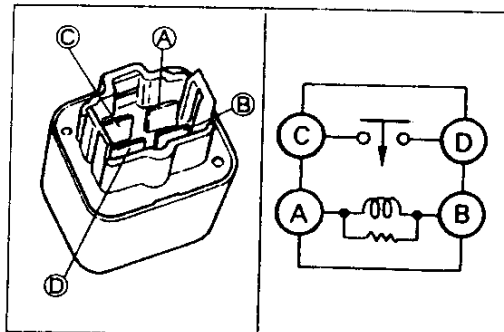

FAN RELAY







Inspection

1. Disconnect cooling fan relay
2. Apply battery voltage and ground to terminal A and B of cooling fan relay.
3. Check continuity of the relay

Operation	C-D terminal
V _B applied	Continuity
V _B Not applied	No continuity

CONTROL SYSTEM

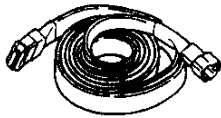
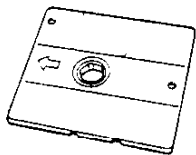
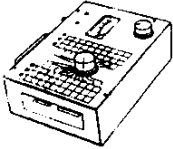
PREPARATION
SST

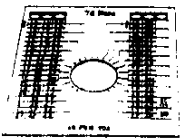
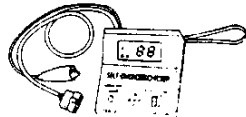
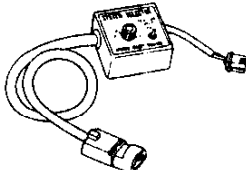
<p>49 F088 001 DT-S1000 Base unit</p> 	<p>For inspection of ECU terminal voltage and input / output devices</p>	<p>49 F088 002 Power unit (DC 12V)</p> 	<p>For inspection of ECU terminal voltage and input / output devices</p>
<p>49 F088 003 Harness Power unit</p> 	<p>For inspection of ECU terminal voltage and input / output devices</p>	<p>49 F088 004 Interface adaptor Type-1</p> 	<p>For inspection of ECU terminal voltage and input / output devices</p>
<p>49 F088 005 Harness Type-1</p> 	<p>For inspection of ECU terminal voltage and input / output devices</p>	<p>49 F088 011 System disk Type-1 (Ver. 1.00)</p> 	<p>For inspection of ECU terminal voltage and input / output devices</p>
<p>49 9200 162 Engine Signal monitor</p> 	<p>For inspection of ECU terminal voltage.</p>	<p>49 F018 902 Adaptor harness</p> 	<p>For inspection of ECU terminal voltage.</p>
<p>49 F018 903 Sheet</p> 	<p>For inspection of ECU terminal voltage</p>	<p>49 H018 9A1 Self-Diagnosis Checker</p> 	<p>For inspection of oxygen sensor and knock sensor</p>
<p>49 B019 9A0 System Selector</p> 	<p>For inspection of oxygen sensor and knock sensor</p>		

F

CONTROL SYSTEM

STRUCTURAL VIEW

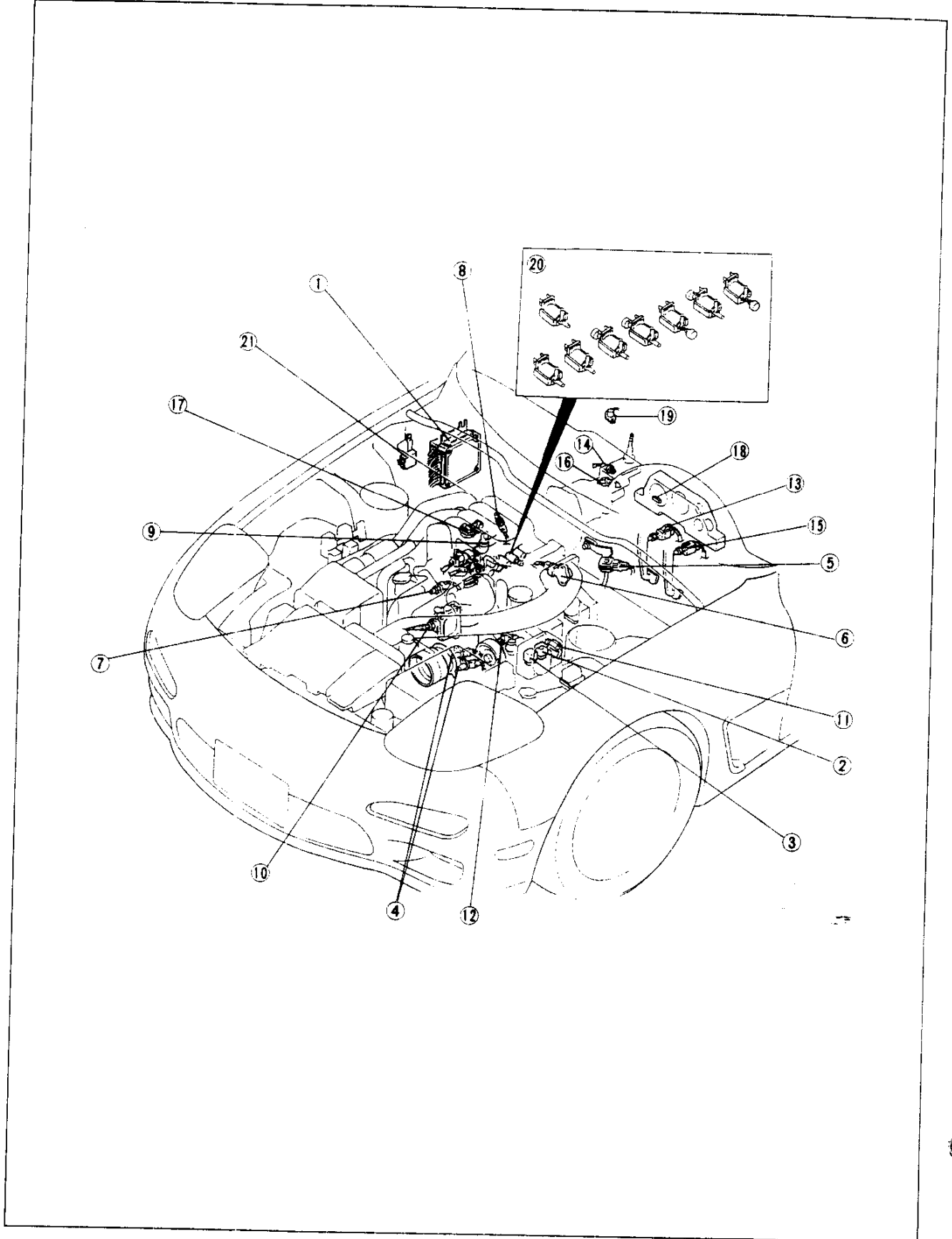

1. Engine control unit (ECU)
 - Removal / Installation page F-150
 - Inspection page F-150
2. Main relay
 - Inspection page F-188
3. Circuit opening relay
 - Inspection (On vehicle) page F-189
 - Inspection page F-189
4. Crank angle sensor
 - Removal / Installation page F-180
 - Inspection page F-180
5. Pressure sensor
 - Inspection page F-181
6. Throttle sensor
 - Inspection page F-182
 - Adjustment page F-182
 - Removal / Installation page F-182
7. Water thermosensor
 - Removal / Installation page F-183
 - Inspection
8. Intake air thermosensor
 - Removal / Installation page F-183
 - Inspection page F-183
9. Fuel thermosensor
 - Removal / Installation page F-184
 - Inspection page F-184
10. Oxygen sensor
 - Inspection page F-184
 - Removal / Installation page F-184
11. Knock sensor
 - Inspection (On vehicle) page F-185
 - Removal / Installation page F-185
12. P/S pressure switch
 - Inspection (On vehicle) page F-186
 - Removal / Installation page F-186
13. Stoplight switch
 - Inspection page F-186
 - Removal / Installation page F-186
14. Neutral switch (MT)
 - Inspection page F-136
 - Removal / Installation page F-136
15. Clutch switch (MT)
 - Inspection page F-137
 - Removal / Installation page F-137
16. 1-2 switch (MT)
 - Inspection page F-137
 - Removal / Installation page F-137
17. EGR switch
 - Inspection page F-127
 - Removal / Installation page F-127
18. Mileage switch
 - Inspection page F-137
19. Heat hazard switch
 - Inspection page F-137
 - Removal / Installation page F-137
20. Solenoid valves
 - Removal / Installation page F-190
 - Inspection page F-191

ENGINE CONTROL UNIT (ECU)

Removal / Installation

1. Remove in the order shown in the figure.
2. Install in the reverse order of removal.

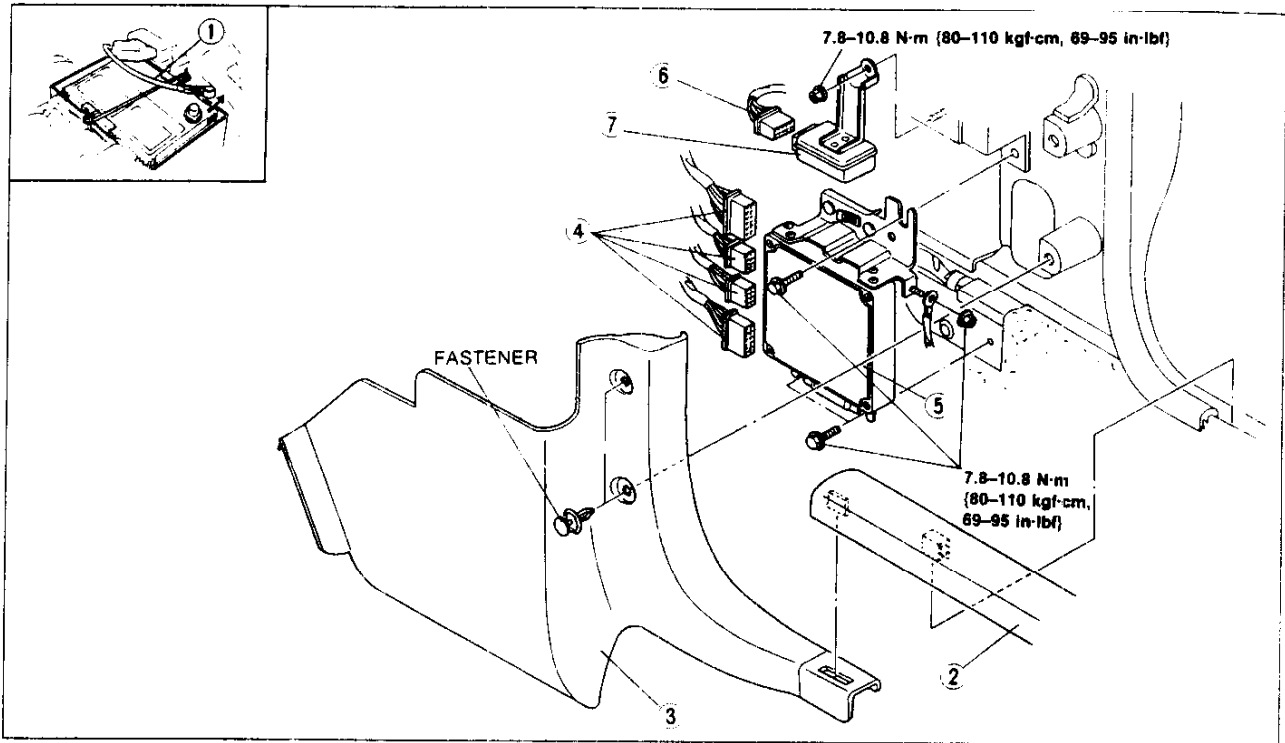

1. Battery cable
2. Scuff plate
3. Front side trim
4. Connectors

5. ECU
Inspection (Engine Signal Monitor) ... below
Inspection (DT-S1000) page F-131
6. Connector
7. E/L unit
Inspection page F-136

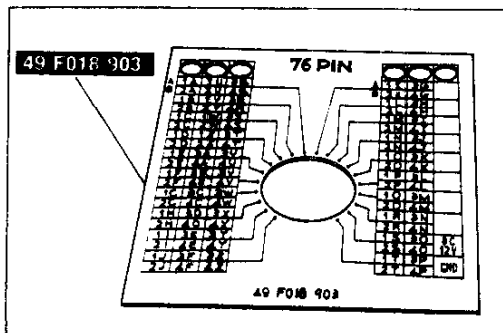
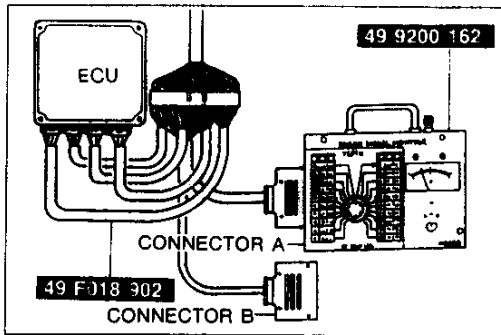

Inspection Engine signal Monitor

1. Connect the **SST** (Engine Signal Monitor) between the ECU and the wiring harness by using the **SST**. (Adaptor)

Note

- Use connector **A** of the adaptor to measure voltage at terminals **1A** through **1V** and **3A** through **3P**, and use connector **B** to measure voltage at terminals **2A** through **2L**, and **4A** through **4Z**.

2. Place the **SST** (Sheet: 76-pin type) on the **SST** (Engine Signal Monitor).
3. Measure the voltage at each terminal.
4. If any ECU terminal voltage is incorrect, check the input or output device and related wiring. If they are normal, replace the ECU.

Caution

- Never apply voltage to **SST** terminals **A** and **B**.

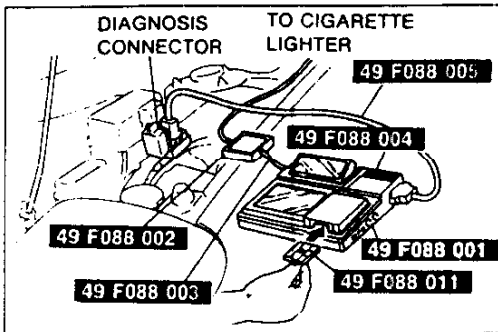

DT-S1000

1. Connect the **DT-S1000** to the diagnosis connector as shown in figure.

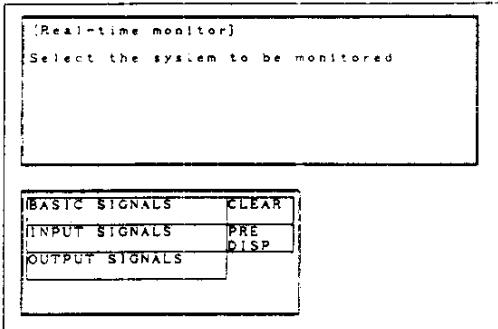

2. Select the real time monitor from the **DT-S1000** display.
3. Turn ignition switch ON.

Caution

- Do not turn the ignition switch OFF until real time monitor is completed.

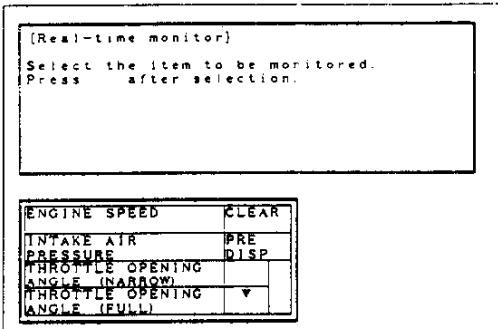

4. Select the inspection items.

Note

- The maximum selection items are 8.
- Basic input signal need two-channel, therefore if all selection items basic input signal. The maximum selection item is 4.

5. Verify indication of respective data item in each condition, referring to ECU terminal condition chart. (Refer to page F-166)

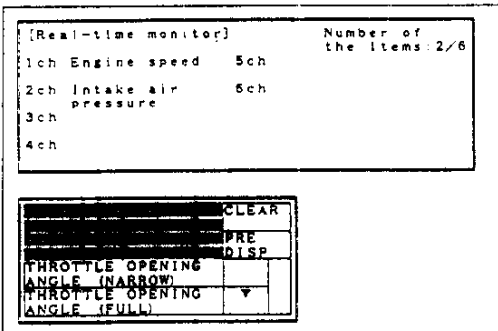

< Example >

When checking the throttle sensor operation pattern at engine speed and intake air pressure, the following steps are available.

Step 1.

Select the engine speed and intake air pressure from Basic signal then select the solenoid valves.

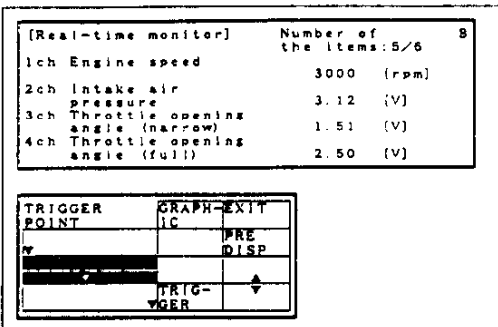

Step 2.

Drive the vehicle and verify that the engine speed (rpm), intake air pressure (kPa), solenoid valves ON/OFF and duty signal (%) valve on the display.

Note

- Referring to the DT-S1000 instruction manual.

F

CONTROL SYSTEM

Terminal voltage

1. Using the engine signal monitor

V_B: Battery voltage

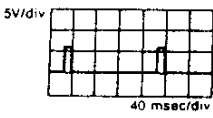
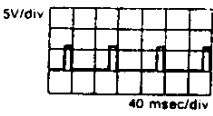
Terminal	Input	Output	Connected to	Test condition	Correct voltage	Remark
1A	-	-	Battery	Constant	V _B	For backup
1B	○		Main relay (FUEL INJ relay)	Ignition switch OFF	0V	-
				ON	V _B	
1C	○		Ignition switch (START)	While cranking	V _B	-
				Ignition switch ON	Below 1.0V	
1D		○	Self-Diagnosis checker (monitor lamp)	Test switch at SELF TEST Lamp illuminated for 3 sec. after ignition switch OFF → ON	4.5-5.5V	With Self-Diagnosis checker and System Selector
				Lamp not illuminated after 3 sec.	V _B	
				Test switch at O ₂ MONITOR Lamp illuminated	4.5-5.5V	
				Test switch at O ₂ MONITOR Lamp not illuminated	V _B	
1E	○		A/C switch	A/C switch ON	Below 3.0V	<ul style="list-style-type: none"> • With Blower SV ON • Ignition switch ON
				A/C switch OFF	V _B	
1F		○	Self-Diagnosis checker (code number)	Buzzer sounded for 3 sec. after ignition switch OFF → ON	Below 2.5V	<ul style="list-style-type: none"> • With Self-Diagnosis checker and System Selector • With System Selector test switch at SELF TEST
				Buzzer not sounded for after 3 sec.	V _B	
				Buzzer sounded	Below 2.5V	
				Buzzer not sounded	V _B	
1G		○	Igniter (Trailing) Front rotor	Ignition switch ON	0V	-
				Idle	0.2-0.5V (Reference)	
				Oscilloscope		
1H		○	Igniter (Leading)	Engine speed: above 2.500 rpm	0.5-0.8V (Reference)	Initial acceleration
				Ignition switch ON	0V	
				Idle	0.2-0.5V (Reference)	
				Oscilloscope		
				Engine speed above 2.500 rpm	0.8-1.2V (Reference)	Initial acceleration

V_B: Battery voltage

Incorrect voltage		Possible cause
Always 0V		<ul style="list-style-type: none"> ● ROOM 10A fuse burnt ● Open circuit in wiring from ROOM 10A fuse to ECU terminal 1A
Always 0V		<ul style="list-style-type: none"> ● Main relay malfunction (Refer to page F-188) ● Open or short circuit in wiring from main relay to ECU terminal 1B
Always 0V (starter turns)		<ul style="list-style-type: none"> ● Open or short circuit in wiring from ignition switch to ECU terminal 1C ● Ignition switch malfunction (Refer to Section T)
Always 0V		<ul style="list-style-type: none"> ● Main relay (FUEL INJ relay) malfunction (Refer to page F-188) ● Open circuit in wiring from ignition switch to diagnosis connector terminal +B ● Open or short circuit in wiring from diagnosis connector terminal MEN to ECU terminal 1D
Always V _B		<ul style="list-style-type: none"> ● Poor connection at ECU connector ● ECU malfunction
Always approx. 5V		ECU malfunction
Always below 1.0V		<ul style="list-style-type: none"> ● Short circuit in wiring from A/C switch to ECU terminal 1E ● A/C switch malfunction (Refer to Section T)
Always V _B		<ul style="list-style-type: none"> ● Open circuit in wiring from A/C switch to ECU terminal 1E ● A/C switch malfunction (Refer to Section T)
Always below 2.5V	No display on Self-Diagnosis Checker	<ul style="list-style-type: none"> ● Main relay (FUEL INJ relay) malfunction (Refer to page F-188) ● Open circuit in wiring from ignition switch to diagnosis connector terminal +E
	"88" displayed and buzzer sounds continuously	Open or short circuit in wiring from diagnosis connector terminal FEN to ECU terminal 1F
Always V _B		<ul style="list-style-type: none"> ● Poor connection at ECU connector ● ECU malfunction
Always 0V		Refer to page F-16 (Ignition timing adjustment)
Always 0V		Refer to page F-16 (Ignition timing adjustment)

F

CONTROL SYSTEM

V_B: Battery voltage

Terminal	Input	Output	Connected to	Test condition	Correct condition	Remark
1I	○		Diagnosis connector (TEN terminal)	System Selector test switch at O ₂ MONITOR	V _B	<ul style="list-style-type: none"> • With System Selector • Ignition switch ON
				System Selector test switch at SELF TEST	0V	
1J		○	Igniter (Trailing) Rear rotor	Ignition switch ON	0V	
				Idle	0.2-0.5V (Reference)	
				Oscilloscope		
1K		○	Fuel pump relay	Engine speed: above 2500 rpm	0.5-0.8V (Reference)	Initial acceleration
				Ignition switch ON	Below 1.0V	
				While cranking	Below 1.0V	
				Idle	<ul style="list-style-type: none"> Solenoid valve (PRC) does not operate Solenoid valve (PRC) operates 	
1L		○	A/C relay	While cranking	V _B	A/C switch, Blower switch ON
				Idle	Below 1.0V	
				During acceleration (Running)	V _E	
1M	○		Speedometer sensor	Ignition switch ON	4.0-5.0V	
				Driving	2.0-2.5V	
1N	○		P/S pressure switch	P/S OFF at idle	V _B	
				P/S ON at idle	Below 1.0V	
		Mileage switch	Under 20,000 miles (34,000 km)	Below 1.5V	Ignition switch ON after 2 seconds	
			Over 20,000 miles (34,000 km)	V _B		
1O	○		Pressure sensor	Ignition switch ON	Approx. 2.6V	
				Idle	Approx. 1.5V	
1P	-	-	-	-	-	-

V_B: Battery voltage

Incorrect condition	Possible cause
Always below 1.0V	Short circuit in wiring from diagnosis connector terminal TEN to ECU terminal 1I
Always V _B	<ul style="list-style-type: none"> ● Open circuit in wiring from diagnosis connector terminal TEN to ECU terminal 1I ● Open circuit in wiring from diagnosis connector terminal GND to ground
Always 0V	Refer to page F-16 (ignition timing adjustment)
Always below 1.0V	Refer to code No.51 Troubleshooting (Refer to page F-60)
Always V _B	<ul style="list-style-type: none"> ● Poor connection at ECU connector ● Fuel pump relay malfunction (Refer to page F-110) ● ECU malfunction
Always V _B	<ul style="list-style-type: none"> ● A/C relay malfunction (Refer to page F-143) ● Open circuit in wiring from ignition switch to A/C relay ● Open circuit in wiring from A/C relay to ECU terminal 1L
Always below 1.0V	<ul style="list-style-type: none"> ● Short circuit in wiring from A/C relay to ECU terminal 1L ● A/C relay malfunction (Refer to page F-143)
Always 0V	<ul style="list-style-type: none"> ● Open or short circuit in wiring from speedometer sensor to ECU terminal 1M ● Speedometer sensor malfunction (Refer to Section T)
Always below 1.0V	<ul style="list-style-type: none"> ● P/S pressure switch malfunction (Refer to page F-186) ● Short circuit in wiring from P/S pressure switch to ECU terminal 1N ● ECU malfunction
Always V _B	<ul style="list-style-type: none"> ● P/S pressure switch malfunction (Refer to page F-186) ● Open circuit in wiring from P/S pressure switch to ECU terminal 1N ● Open circuit in wiring from P/S pressure switch to ground
Always V _B under 20,000 miles	<ul style="list-style-type: none"> ● Mileage switch malfunction (Refer to page F-189) ● ECU malfunction
Always below 1.5V over 20,000 miles	<ul style="list-style-type: none"> ● Mileage switch malfunction (Refer to page F-189) ● ECU malfunction
Always 0V or 5V	Refer to Code No.13 Trouble shooting (Refer to page F-33)

F

CONTROL SYSTEM

Terminal	Input	Output	Connected to	Test condition	Correct voltage	Remark
1Q	○		Clutch switch (MT)	Clutch pedal: released	V_B	Ignition switch ON
				Clutch pedal: depressed	Below 1.0V	
			EC-AT control unit (AT)	Idle	V_B	Reduce torque signal
				When slip lockup from 1st to 2nd or from 2nd to 3rd with the throttle opening above 1.5/8	Below 1.0V	
1R	○		Neutral switch (MT)	Neutral	Below 1.0V	Ignition switch ON
				In gear	V_B	
			EC-AT control unit (AT)	Por N range	Below 1.0V	● Inhibitor signal ● Ignition switch ON
				Other	V_B	
1S	○		Stoplight switch	Brake pedal released	Below 1.0V	Ignition switch ON
				Brake pedal depressed	V_B	
1T		○	Circuit opening relay	Ignition switch ON	V_B	
1U	○		Fuel thermosensor	Idle	Below 1.0V	
				Idle (after warm up)	1.5-3.0V	
1V	-	-	-	-	-	-
2A	-	-	-	-	-	-
2B		○	Diagnosis connector (IG-terminal)	Ignition switch ON	0V	
				Idle	0.3-0.8 (Reference)	
2C		○	EC-AT (AT) control unit	Engine speed: 3,000 rpm	1.8-2.2V (Reference)	Initial acceleration
				Idle	V_e	Slip lock up OFF signal
				Engine speed: hold 3,000 rpm (after 5 seconds)	Below 1.0V	Initial acceleration
2D		○	EC-AT control unit (AT)	Ignition switch ON	2-4.5V	Atmospheric pressure signal
2E		○	EC-AT control unit (AT)	Idle	Below 1.0V	Idle signal
				Other	Approx 5V	
2F		○	Open (ex. Canada)	Constant	1-2.5V	
			Ground (Canada)	Constant	0V	
2G		○	EC-AT control unit (AT)	Idle	V_B	Torque reduced signal
				Throttle opening above 1/8 (Engine coolant temp. below 40°C {104°F})	Below 1.0V	
2H	-	-	-	-	-	-
2I	○		Heat Hazard Sensor	Ignition switch ON	Below 2.0V	
				Idle (Temp.: Below 100°C {212°F})	V_B	
				Idle (Temp. Above 100°C {212°F})	Below 1.0V	
2J		○	A/P relay	Engine speed Idle-Below 3,250 rpm	Below 1.0V	
				Engine speed above 3,250 rpm	V_B	

V_B : Battery voltage

CONTROL SYSTEM

F

V_B: Battery voltage

Incorrect voltage	Possible cause
Always V _B	<ul style="list-style-type: none"> ● Clutch switch malfunction (Refer to page F-187) ● Open circuit in wiring from clutch switch to ECU terminal 1Q
Always below 1.0V	<ul style="list-style-type: none"> ● Clutch switch malfunction (Refer to page F-187) ● Short circuit in wiring from clutch switch to ECU terminal 1Q
Always V _B	<ul style="list-style-type: none"> ● Open circuit in wiring from ECU terminal 1Q to EC-AT C.U terminal 2P
Always below 1.0V	<ul style="list-style-type: none"> ● Short circuit in wiring from ECU terminal 1Q to EC-AT C.U terminal 2P
Always below 1.0V	<ul style="list-style-type: none"> ● Neutral switch malfunction (Refer to page F-186) ● Short circuit in wiring from neutral switch to ECU terminal 1R
Always V _B	<ul style="list-style-type: none"> ● Neutral switch malfunction (Refer to page F-186) ● Open circuit in wiring from neutral switch to ECU terminal 1R
Always below 1.0V	<ul style="list-style-type: none"> ● Inhibitor switch malfunction (Refer to Section K) ● Short circuit in wiring from EC-AT control unit terminal 1C to ECU terminal 1R
Always V _B	<ul style="list-style-type: none"> ● Inhibitor switch malfunction (Refer to Section K) ● Open circuit in wiring from EC-AT control unit terminal 1C to ECU terminal 1R
Always below 1.0V (Stoptight OK)	Open circuit in wiring from stoptight switch to ECU terminal 1S
Always below 1.0V or V _B	<ul style="list-style-type: none"> ● Open or short circuit in wiring from circuit opening relay to ECU terminal 1T ● Circuit opening relay malfunction (Refer to page F-188)
Always Approx. 0V or approx 5V	Refer to Code No.23 Troubleshooting (Refer to page F-40)
-	-
-	-
Always 0V	<ul style="list-style-type: none"> ● Open circuit in wiring from diagnosis connector IG-terminal to ECU terminal 2B ● Crank angle sensor malfunction (Refer to page F-180) ● ECU malfunction
Always V _B	Open circuit in wiring from EC-AT C.U terminal 2G to ECU terminal 2C
Always below 1.0V	Short circuit in wiring from EC-AT C.U terminal 2G to ECU terminal 2C
Always 0V or 4V	<ul style="list-style-type: none"> ● Refer to code No 14 Troubleshooting (Refer to page F-34) ● Open or short circuit in wiring from EC-AT C.U terminal 2C to ECU terminal 2D
Always below 1.0V	Short circuit in wiring from EC-AT C.U terminal 2M to ECU terminal 2E
Always V _B	Open circuit in wiring from EC-AT C.U terminal 2M to ECU terminal 2E
Always 0V	Short circuit in wiring ECU terminal 2F to ground.
Always approx. 5V	Open circuit in wiring ECU terminal 2F to ground.
Always below 1.0V	Short circuit in wiring from EC-AT C.U terminal 2P to ECU terminal 2G
Always V _B	Open circuit in wiring from EC-AT C.U terminal 2P to ECU terminal 2G
-	-
Always below 1.0V	<ul style="list-style-type: none"> ● Short circuit in wiring from heat hazard sensor to ECU terminal 2I ● Heat hazard sensor malfunction (Refer to page F-189)
Always V _B	<ul style="list-style-type: none"> ● Open circuit in wiring from heat hazard sensor to ECU terminal 2I ● Heat hazard sensor malfunction (Refer to page F-189)
Always below 1.0V or V _B	Refer to Code No 54 Troubleshooting (Refer to page F-61)

F

CONTROL SYSTEM

V_B: Battery voltage

Terminal	Input	Output	Connected to	Test condition	Correct voltage	Remark						
2K	○		1-2 switch (MT)	1st position	V _B	Ignition switch ON						
				Other	Below 1.0V							
			EC-AT CU (AT)	2nd or 3rd position	Below 1.0V	While running						
				Other	V _B							
2L	○		1-2 switch (MT)	2nd position	Below 1.0V	Ignition switch ON						
				Other	V _B							
			EC-AT CU (AT)	3rd or O/D position	Below 1.0V	While running						
				Other	V _B							
3A	○		Metering oil pump position sensor	Ignition switch ON	1.0-4.2V	Voltage increase when accelerating						
				idle	Approx. 1.1V							
				Accelerator pedal depressed	1.1-4.2V							
3B	○		E/L unit	Headlight switch position I, II	Below 4.0V							
				Blower motor position III, IV								
				Rear defroster switch ON								
				Headlight switch, Blower motor, rear defroster switch are OFF	5V							
3C	○		Oxygen sensor	Idle	Cold engine	Approx 0V	<p>Oscilloscope</p> <p>VOLTAGE (V)</p> <p>0.5 s/div</p>					
					After warm up	0.0-1.0V						
				Acceleration (after warm up)	0.5-1.0V							
				Deceleration (after warm up)	0.0-0.4V							
				3D		○		Cooling fan relay	Idle	During electrical cooling fan operating	V _B	
										Electrical cooling fan does not operate	Below 1.0V	
				TFA terminal of diagnosis connector is grounded	Below 1.0V	Ignition switch ON						
3E	○		Water thermosensor	Engine coolant temperature 20°C {68°F}	Approx. 2.5V	Ignition switch ON						
				After warm up	Below 0.5V							
3F	○		Throttle sensor (Narrow range)	Accelerator pedal released	0.75-1.25	<ul style="list-style-type: none"> ● Ignition switch ON ● After warm-up 						
				Accelerator pedal fully depressed	4.8-5.0							
3G	○		Throttle sensor (Full range)	Accelerator pedal released	0.1-0.7	<ul style="list-style-type: none"> ● Ignition switch ON ● After warm-up 						
				Accelerator pedal fully depressed	4.2-4.6							
3H		○	Solenoid valve (purge control)	Ignition switch ON	V _B							
				idle								
				Engine speed: 1,500-3,300 rpm	4-10V		While running					

V_B : Battery voltage

Incorrect voltage	Possible cause
Always below 1.0V	<ul style="list-style-type: none"> ● Short circuit in wiring from 1-2 switch to ECU terminal 2K ● 1-2 switch malfunction (Refer to page F-187)
Always V_B	<ul style="list-style-type: none"> ● Open circuit in wiring from 1-2 switch to ECU terminal 2K ● 1-2 switch malfunction (Refer to page F-187)
Always below 1.0V	Short circuit in wiring from EC-AT CU terminal 1D to ECU terminal 2K
Always V_B	Open circuit in wiring from EC-AT CU terminal 1D to ECU terminal 2K
Always below 1.0V	<ul style="list-style-type: none"> ● Short circuit in wiring from 1-2 switch to ECU terminal 2L ● 1-2 switch malfunction (Refer to page F-187)
Always V_B	<ul style="list-style-type: none"> ● Open circuit in wiring from 1-2 switch to ECU terminal 2L ● 1-2 switch malfunction (Refer to page F-187)
Always below 1.0V	● Short circuit in wiring from EC-AT CU terminal 1B to ECU terminal 2L
Always V_B	● Open circuit in wiring from EC-AT CU terminal 1B to ECU terminal 2L
Always approx 0V or approx 5V	Refer to Code No.27 Troubleshooting (Refer to page F-43)
Always below 1.0V	<ul style="list-style-type: none"> ● Short circuit in wiring from switches ~ E/L unit ~ ECU terminal 3B ● Switches malfunction (Refer to Section T)
Always V_B	<ul style="list-style-type: none"> ● Open circuit in wiring from switches ~ E/L unit ~ ECU terminal 3B ● Switches malfunction (Refer to Section T)
0V after warm-up	Refer to Code No.15 Troubleshooting (Refer to page F-34)
Always approx. 1V after warm-up	Refer to Code No.17 Troubleshooting (Refer to page F-36)
Always below 1.0V or Always V_B	<ul style="list-style-type: none"> ● Open or short circuit in wiring from cooling fan relay to ECU terminals 3D ● Fan relay malfunction (Refer to page F-147) ● ECU malfunction
Always approx. 0V or approx. 5V	Refer to Code No.09 Troubleshooting (Refer to page F-30)
Always approx. 0V	Refer to Code No.12 Troubleshooting (Refer to page F-32)
Always approx. 5V	
Always approx. 0V	Refer to Code No.18 Troubleshooting (Refer to page F-38)
Always approx. 5V	
Always 0V or V_B	Refer to Code No.40 Troubleshooting (Refer to page F-53)

F

CONTROL SYSTEM

V_B: Battery voltage

Terminal	Input	Output	Connected to	Test condition	Correct voltage	Remark
3I	○		Throttle sensor	Constant	Approx. 5.0V	Ignition switch ON
3J	○		EGR switch	EGR valve operates	V _B	California only
				EGR valve does not operate	Below 1.0V	
	○		DRL relay	Idle	0V	Canada only
				Pull the parking brake (Turnlight OFF) Release the parking brake (Turnlight ON)	V _B	
3K		○	Solenoid valve (Relief2)	Ignition switch ON	V _B	
				Idle	Before warm up approx. 40°C (104°F) After warm up	
3L	○		Intake air thermosensor	Ambient air temperature 20°C (68°F)	Approx. 2.5V	Ignition switch ON
				After warm up	Approx. 0.6V	
3M	○		Knock sensor	Ignition switch ON	Approx. 2.5V	Ignition switch ON
				Knocking occur (Tap the engine hanger with hammer)	2.6-2.8V (Reference)	
3N		○	Solenoid valve (Port air by-pass)	Ignition switch ON	V _B	While running
				After warm up Engine speed: 1,500-3,000 rpm	Below 1.0V	
3O		○	Solenoid valve (Double throttle control)	Engine coolant temperature below 80°C (176°F)	Below 1.0V	Ignition switch ON
				After warm up	V _B	
3P		○	Solenoid valve (Relief1)	Idle	V _B	<ul style="list-style-type: none"> ● After warm up ● While running
				Engine speed: 2,700-3,200 rpm	Below 1.0V	
4A	-	-	Ground (Output)	Constant	0V	-
4B	-	-	Ground (Output)	Constant	0V	-
4C	-	-	Ground (CPU)	Constant	0V	-
4D	-	-	Ground (Input)	Constant	0V	-
4E	○		Crank angle sensor [NE - signal]	Ignition switch ON	Below 1.0V	Engine signal monitor: Red lamp flash
				Idle	Oscilloscope	
4F		○	Solenoid valve (Split air by-pass)	Idle	V _B	<ul style="list-style-type: none"> ● After warm up ● While running
				5th position (MT) / OD (AT)	Below 1.0V	
4G	○		Crank angle sensor [G signal]	Ignition switch ON	Below 1.0V	
				Idle	Oscilloscope	
				Voltmeter	0.1-0.4V (Reference)	
				Voltmeter	0.1-0.4V (Reference)	

V_B : Battery voltage

Incorrect voltage	Possible cause
Always 0V	<ul style="list-style-type: none"> ● Short circuit in wiring from main relay to ECU terminal 3I ● Main relay malfunction (Refer to page F-188)
Always 0V or V_B	<ul style="list-style-type: none"> ● EGR switch malfunction (Refer to page F-127) ● Open or short circuit in wiring from EGR switch to ECU terminal 3J
	<ul style="list-style-type: none"> ● DRL relay malfunction (Refer to section T) ● Open or short circuit in wiring from DRL relay to ECU terminal 3J
Always below 1.0V or V_B	Refer to Code No.39 Troubleshooting (Refer to page F-52)
Always 0V or approx. 5V	Refer to Code No.11 Troubleshooting (Refer to page F-31)
Always 0V	Refer to Code No.05 Troubleshooting (Refer to page F-28)
Always below 1.0V or V_B	Refer to Code No.33 Troubleshooting (Refer to page F-48)
Always below 1.0V or V_B	Refer to Code No.50 Troubleshooting (Refer to page F-59)
Always below 1.0V or V_B	Refer to Code No.31 Troubleshooting (Refer to page F-46)
Above 0V	<ul style="list-style-type: none"> ● Poor connection at ground terminal ● Open circuit in wiring from ECU
Always approx. 0V or approx. 5V	Refer to Code No.03 Troubleshooting (Refer to page F-27)
Always below 1.0V or V_B	Refer to Code No.30 Troubleshooting (Refer to page F-45)
Always approx. 0V or approx. 5V	Refer to Code No.02 Troubleshooting (Refer to page F-26)

F

CONTROL SYSTEM

V_B: Battery voltage

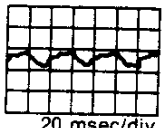
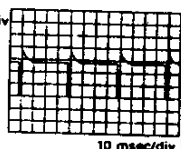
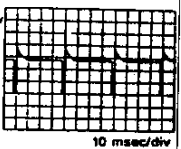
Terminal	Input	Output	Connected to	Test condition	Correct voltage	Remark	
4H	○		Crank angle sensor	Constant	Below 1.0V	-	
4I		○	Stepping motor (Metering oil pump)	Ignition switch ON	V _B	3 terminals / 4 terminals V _B Other terminal 5-9V	
4J	Idle						
4K							
4L							
4M		○	Solenoid valve (Pressure regulator control)	Idle	V _B	Below 1.0V	approx. 1 minute
				Idle after hot start			
4N		○	Solenoid valve (Switching)	Ignition switch ON/Idle Engine speed: above 3,200 rpm (After warm up)	V _B Below 1.0V	Initial acceleration	
4O		○	Solenoid valve (EGR)	Idle	V _B	Below 1.0V	While running
				5th position (MT)/OD (AT)			
4P		○	Solenoid valve (AWS)	Before warm up approx 40°C (104°F)	Below 1.0V	Below 1.0V	Idle
				After warm up			
4Q		○	Solenoid valve (ISC)	Ignition switch ON	8.0-11.0V	5.0-11.0 (Reference) 5V/div	Reference valve ● Cranking 99% ● Idle 32-65% ● Initial set 38%
				Idle	Oscilloscope  20 msec/div		
4R		○	Solenoid valve (Turbo control)	Idle	V _B	Below 1.0V	Initial acceleration
				Engine speed: above 5,500 rpm (MT)			
				Engine speed: above 5,250 rpm (AT)			
4S		○	Solenoid valve (Charge relief)	Idle	V _B	Below 1.0V	Initial acceleration
				Engine speed: 4,000-5,500 rpm (MT) for 8 sec. 3,500-5,000 (AT) for 4 sec.			
				Engine speed: above 5,500 rpm (MT) above 5,250 rpm (AT)			
4T		○	Solenoid valve (Charge control)	Idle	Below 1.0V	V _B	Initial acceleration
				Engine speed: above 5,500 rpm (MT)			
				Engine speed: above 5,250 rpm (AT)			
4U		○	Solenoid valve (Wastegate control)	Ignition switch ON	V _B	5V/div	Reference valve ● Idle 5% ● Solenoid valve (Turbo control) before operates 95%
				Idle	Oscilloscope  10 msec/div		
				Initial acceleration	5.0-11.0 V		
4V		○	Solenoid valve (Turbo precontrol)	Ignition switch ON	V _B	5V/div	Reference valve ● Idle 5% ● Solenoid valve (Turbo control) after operates 5%
				Idle	Oscilloscope  10 msec/div		
				Engine speed: above 3,000 rpm	4.0-10.0V (Reference)		

CONTROL SYSTEM

F

V_B : Battery voltage

Incorrect voltage	Possible cause
Always above 1.0V	Refer to Code No.02 Troubleshooting (Refer to page F-26)
Always 0v or V_B	Refer to Code No.26 Troubleshooting (Refer to page F-42)
Always below 1.0V or V_B	Refer to Code No.25 Troubleshooting (Refer to page F-41)
Always below 1.0V or V_B	Refer to Code No.32 Troubleshooting (Refer to page F-47)
Always below 1.0V or V_B	Refer to Code No.28 Troubleshooting (Refer to page F-44)
Always below 1.0V or V_B	Refer to Code No.38 Troubleshooting (Refer to page F-51)
Always below 1.0V or V_B	Refer to Code No.34 Troubleshooting (Refer to page F-49)
Always below 1.0V or V_B	Refer to Code No.44 Troubleshooting (Refer to page F-56)
Always below 1.0V or V_B	Refer to Code No.46 Troubleshooting (Refer to page F-58)
Always below 1.0V or V_B	Refer to Code No.45 Troubleshooting (Refer to page F-57)
Always below 1.0V or V_B	Refer to Code No.43 Troubleshooting (Refer to page F-55)
Always below 1.0V or V_B	Refer to Code No.42 Troubleshooting (Refer to page F-54)

F

CONTROL SYSTEM

V_B: Battery voltage

Terminal	Input	Output	Connected to	Test condition	Correct voltage	Remark
4W		○	Injector (Front primary)	Ignition switch ON idle*	V _B 12-14V	<ul style="list-style-type: none"> • Secondary injector not working at no load condition * Engine Signal Monitor: Green lamp flash
4X		○	Injector (Front secondary)			
4Y		○	Injector (Rear primary)			
4Z		○	Injector (Rear secondary)			

Oscilloscope

16E0F2 219

Control Unit Connector (Control Unit Side)

4Y	4W	4U	4S	4Q	4O	4M	4K	4I	4G	4E	4C	4A	3O	3M	3K	3I	3G	3E	3C	3A	2K	2I	2G	2E	2C	2A	U	S	Q	O	M	K	I	G	E	C	A
4Z	4X	4V	4T	4R	4P	4N	4L	4J	4H	4F	4D	4B	3P	3N	3L	3J	3H	3F	3D	3B	2L	2J	2H	2F	2D	2B	V	T	R	P	N	L	J	H	F	D	B

V_B: Battery voltage

Incorrect voltage	Possible cause
Always 0V	<ul style="list-style-type: none">● Open or short circuit in wiring from injector to ECU terminal 4W, 4X, 4Y, or 4Z● Main relay malfunction (Refer to page F-188)● Refer to troubleshooting

F

CONTROL SYSTEM

Using the DT-S1000

mark terminal can use the DT-S1000, if no mark use the circuit tester or oscilloscope.

V_B Battery voltage

Terminal	Input	Output	Connected to	Test condition	Correct condition	Remark
1A	-	-	Battery	Constant	V_B	For backup
1B 	○		Main relay (FUEL INJ relay)	Ignition switch OFF	11-13V	-
				ON	12-14V	
1C 	○		Ignition switch (START)	While cranking	OFF	-
				Ignition switch ON	ON	
1D		○	Self-Diagnosis Checker (monitor lamp)	Test switch at SELF TEST Lamp illuminated for 3 sec. after ignition switch OFF → ON	4.5-5.5V	With Self-Diagnosis Checker and System Selector
				Lamp not illuminated after 3 sec.	V_B	
				Test switch at O ₂ MONITOR Lamp illuminated	4.5-5.5V	
				Test switch at O ₂ MONITOR Lamp; not illuminated	V_B	
1E 	○		A/C switch	A/C switch ON	ON	<ul style="list-style-type: none"> • With Blower SW ON • Ignition switch ON
				A/C switch OFF	OFF	
1F		○	Self-Diagnosis Checker (code number)	Buzzer sounded for 3 sec. after ignition switch OFF → ON	Below 2.5V	<ul style="list-style-type: none"> • With Self-Diagnosis Checker and System Selector • With System Selector test switch at SELF TEST
				Buzzer not sounded after 3 sec	V_B	
				Buzzer sounded	Below 2.5V	
				Buzzer not sounded	V_B	
1G 		○	Igniter (Trailing) Front rotor	Idle	BTDC -20°C	
				Engine speed: 2,500 rpm	BTDC 15-35°C	
1H 		○	Igniter (Leading)	Idle	BTDC -5°C	
				Engine speed: above 2,500 rpm	BTDC 15-35°C	

V_B: Battery voltage

Incorrect condition		Possible cause
Always 0V		<ul style="list-style-type: none"> ● ROOM 10A fuse burnt ● Open circuit in wiring from ROOM 10A fuse to ECU terminal 1A
Always 0V		<ul style="list-style-type: none"> ● Main relay malfunction (Refer to page F-188) ● Open or short circuit in wiring from main relay to ECU terminal 1B
Always OFF (starter turns)		<ul style="list-style-type: none"> ● Open or short circuit in wiring from ignition switch to ECU terminal 1C ● Ignition switch malfunction (Refer to Section T)
Always 0V		<ul style="list-style-type: none"> ● Main relay (FUEL INJ relay) malfunction (Refer to page F-188) ● Open circuit in wiring from ignition switch to diagnosis connector terminal +B ● Open or short circuit in wiring from diagnosis connector terminal MEN to ECU terminal 1D
Always V _B		<ul style="list-style-type: none"> ● Poor connection at ECU connector ● ECU malfunction
Always approx. 5V		ECU malfunction
Always ON		<ul style="list-style-type: none"> ● Short circuit in wiring from A/C switch to ECU terminal 1E ● A/C switch malfunction (Refer to Section T)
Always OFF		<ul style="list-style-type: none"> ● Open circuit in wiring from A/C switch to ECU terminal 1E ● A/C switch malfunction (Refer to Section T)
Always below 2.5V	No display on Self-Diagnosis Checker	<ul style="list-style-type: none"> ● Main relay (FUEL INJ relay) malfunction (Refer to page F-188) ● Open circuit in wiring from ignition switch to diagnosis connector terminal +B
	"88" displayed and buzzer sounds continuously	Open or short circuit in wiring from diagnosis connector terminal FEN to ECU terminal 1F
Always V _B		<ul style="list-style-type: none"> ● Poor connection at ECU connector ● ECU malfunction
Different ignition timing		Refer to page F-16 (Ignition timing adjustment)
Different ignition timing		Refer to page F-16 (Ignition timing adjustment)

F

CONTROL SYSTEM

V_B: Battery voltage

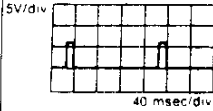
Terminal	Input	Output	Connected to	Test condition	Correct condition	Remark
1I	○		Diagnosis connector (TEN terminal)	System Selector test switch at O ₂ MONITOR	V _B	<ul style="list-style-type: none"> ● With System Selector ● Ignition switch ON
				System Selector test switch at SELF TEST	0V	
1J		○	Igniter (Trailing) Rear rotor	Ignition switch ON	0V	
				Idle	0.2-0.5V (Reference)	
				Oscilloscope		
1K DT S 1.120		○	Fuel pump relay	Engine speed: above 2,500 rpm	0.5-0.8V (Reference)	Initial acceleration
				Ignition switch ON	ON	
				While cranking	ON	
				Idle	Solenoid valve (PRC) does not operate Solenoid valve (PRC) operates	
1L DT S 1.120		○	A/C relay	While cranking	OFF	A/C switch, Blower switch ON
				Idle	ON	
				During acceleration (Running)	OFF	
1M DT S 1.120	○		Speedometer sensor	Ignition switch ON	0 km/h	
				Driving (20km/h)	18-22 km/h	
1N DT S 1.120	○		P/S pressure switch	P/S OFF at idle	OFF	
				P/S ON at idle	ON	
		Mileage switch	Under 20,000 miles {34,000 km}	Below 1.5V	Ignition switch ON after 2 seconds	
			Over 20,000 miles {34,000 km}	V _B		
1O DT S 1.120	○		Pressure sensor	Idle	- 64--66.7 kPa	<ul style="list-style-type: none"> ● After warm-up ● Initial acceleration
				Engine speed: 1,000 rpm	- 46.7--60 kPa	
				Engine speed 2,000 rpm	- 26.7--46.7 kPa	
1P	-	-	-	-	-	-

V_B: Battery voltage

Incorrect condition	Possible cause
Always below 1.0V	Short circuit in wiring from diagnosis connector terminal TEN to ECU terminal 1I
Always V _B	<ul style="list-style-type: none"> ● Open circuit in wiring from diagnosis connector terminal TEN to ECU terminal 1I ● Open circuit in wiring from diagnosis connector terminal GND to ground
Always 0V	Refer to page F-16 (Ignition timing adjustment)
Always OFF	Refer to code No.51 Troubleshooting (Refer to page F-60)
Always OFF	<ul style="list-style-type: none"> ● A/C relay malfunction (Refer to page F-143) ● Open circuit in wiring from ignition switch to A/C relay ● Open circuit in wiring from A/C relay to ECU terminal 1L
Always ON	<ul style="list-style-type: none"> ● Short circuit in wiring from A/C relay to ECU terminal 1L ● A/C relay malfunction (Refer to page F-143)
Always 0 km/h	<ul style="list-style-type: none"> ● Open or short circuit in wiring from speedometer sensor to ECU terminal 1M ● Speedometer sensor malfunction (Refer to Section T)
Always ON	<ul style="list-style-type: none"> ● P/S pressure switch malfunction (Refer to page F-186) ● Short circuit in wiring from P/S pressure switch to ECU terminal 1N ● ECU malfunction
Always OFF	<ul style="list-style-type: none"> ● P/S pressure switch malfunction (Refer to page F-186) ● Open circuit in wiring from P/S pressure switch to ECU terminal 1N ● Open circuit in wiring from P/S pressure switch to ground
Always V _B under 20,000 miles	<ul style="list-style-type: none"> ● Mileage switch malfunction (Refer to page F-189) ● ECU malfunction
Always below 1.5V over 20,000 miles	<ul style="list-style-type: none"> ● Mileage switch malfunction (Refer to page F-189) ● ECU malfunction
Different pressure	Refer to Code No.13 Troubleshooting (Refer to page F-33)

F

CONTROL SYSTEM

V_B: Battery voltage

Terminal	Input	Output	Connected to	Test condition	Correct condition	Remark
1Q DT S 1300	○		Clutch switch (MT)	Clutch pedal: released	OFF	Ignition switch ON
				Clutch pedal: depressed	ON	
			EC-AT control unit (AT)	Idle	OFF	Reduce torque signal
				When shifting from 1st to 2nd or from 2nd to 3rd with the throttle opening above 1.5/8	ON	
				Idle	OFF	Slip lock up signal
When slip lockup with the throttle opening below 0.5/8	ON					
1R DT S 1000	○	Neutral switch (MT)	Neutral	ON	Ignition switch ON	
			In gear	OFF		
		EC-AT control unit (AT)	P or N range	ON	● Inhibitor signal ● Ignition switch ON	
			Other	OFF		
1S DT S 1020	○	Stoplight switch	Brake pedal released	OFF	Ignition switch ON	
			Brake pedal depressed	ON		
1T DT S 1020	○	Circuit opening relay	Ignition switch ON	OFF	-	
			Idle	ON		
1U DT S 1000	○	Fuel thermosensor	Fuel temperature 20°C	20°C		
			Fuel temperature 40°C	40°C		
			Fuel temperature 60°C	60°C		
1V	-	-	-	-	-	-
2A	-	-	-	-	-	-
2B DT S 1020	○	Diagnosis Connector (IG-terminal)	Idle	700-750 rpm	● After warm-up ● No electrical load	
			Engine speed: hold 3,000 rpm (after 5 seconds)	ON		Initial acceleration
2C DT S 1020	○	EC-AT (AT) control unit	Idle	OFF	Slip lock up OFF signal	
			Engine speed: hold 3,000 rpm (after 5 seconds)	ON	Initial acceleration	
2D	○	EC-AT control unit (AT)	Ignition switch ON	2-4.5V	Atmospheric pressure signal	
2E DT S 1020	○	EC-AT control unit (AT)	Idle	ON	Idle signal	
			Other	OFF		
2F DT S 1020	○	Open (ex. Canada)	Constant	OFF	-	
		Ground (Canada)	Constant	ON		
2G DT S 1020	○	EC-AT control unit (AT)	Idle	OFF	Torque reduced signal	
			Throttle opening above 1/8 (Engine coolant temp. below 40°C {104°F})	ON		
2H	-	-	-	-	-	-
2I DT S 1020	○	Heat Hazard Sensor	Ignition switch ON	ON		
			Idle (Temp. Below 100°C {212°F})	OFF		
			Idle (Temp. Above 100°C {212°F})	ON		
2J DT S 1020	○	A/P relay	Engine speed Idle-below 3,750 rpm	ON		
			Engine speed above 3,750 rpm	OFF		

V_B: Battery voltage

Incorrect condition	Possible cause
Always OFF	<ul style="list-style-type: none"> ● Clutch switch malfunction (Refer to page F-187) ● Open circuit in wiring from clutch switch to ECU terminal 1Q
Always ON	<ul style="list-style-type: none"> ● Clutch switch malfunction (Refer to page F-187) ● Short circuit in wiring from clutch switch to ECU terminal 1Q
Always OFF	Open circuit in wiring from ECU terminal 1Q to EC-AT C.U terminal 2P
Always ON	Short circuit in wiring from ECU terminal 1Q to EC-AT C.U terminal 2P
Always ON	<ul style="list-style-type: none"> ● Neutral switch malfunction (Refer to page F-186) ● Short circuit in wiring from neutral switch to ECU terminal 1R
Always OFF	<ul style="list-style-type: none"> ● Neutral switch malfunction (Refer to page F-186) ● Open circuit in wiring from neutral switch to ECU terminal 1R
Always ON	<ul style="list-style-type: none"> ● Inhibitor switch malfunction (Refer to section K) ● Short circuit in wiring from EC-AT C.U terminal 1C ECU terminal 1R
Always OFF	<ul style="list-style-type: none"> ● Inhibitor switch malfunction (Refer to section K) ● Open circuit in wiring from EC-AT C.U terminal 1C ECU terminal 1R
Always OFF (Stoplight OK)	Open circuit in wiring from stoplight switch to ECU terminal 1S
Always ON or OFF	<ul style="list-style-type: none"> ● Open or short circuit in wiring from circuit opening relay to ECU terminal 1T ● Circuit opening relay malfunction (Refer to page F-188)
Different temperature	Refer to Code No.23 Troubleshooting (Refer to page F-40)
-	-
-	-
Always 229 rpm	<ul style="list-style-type: none"> ● Open circuit in wiring from diagnosis connector IG-terminal to ECU terminal 2B ● Crank angle sensor malfunction (Refer to page F-180) ● ECU malfunction
Always OFF	Open circuit in wiring from EC-AT C.U terminal 2G to ECU terminal 2C
Always ON	Short circuit in wiring from EC-AT C.U terminal 2G to ECU terminal 2C
Always 0V or 4V	<ul style="list-style-type: none"> ● Refer to code No.14 Troubleshooting (Refer to page F-34) ● Open or short circuit in wiring from EC-AT C.U terminal 2C to ECU terminal 2D
Always ON	Short circuit in wiring from EC-AT C.U terminal 2M to ECU terminal 2E
Always OFF	Open circuit in wiring from EC-AT C.U terminal 2M to ECU terminal 2E
Always ON	Short circuit in wiring ECU terminal 2F to ground.
Always OFF	Open circuit in wiring ECU terminal 2F to ground.
Always ON	Short circuit in wiring from EC-AT C.U terminal 2P to ECU terminal 2G
Always OFF	Open circuit in wiring from EC-AT C.U terminal 2P to ECU terminal 2G
-	-
Always ON	<ul style="list-style-type: none"> ● Short circuit in wiring from heat hazard sensor to ECU terminal 2I ● Heat hazard sensor malfunction (Refer to page F-189)
Always OFF	<ul style="list-style-type: none"> ● Open circuit in wiring from heat hazard sensor to ECU terminal 2I ● Heat hazard sensor malfunction (Refer to page F-189)
Always ON or OFF	Refer to Code No.54 Troubleshooting (Refer to page F-61)

F

CONTROL SYSTEM

V_B: Battery voltage

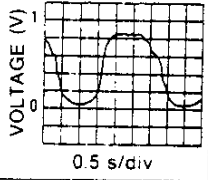
Terminal	Input	Output	Connected to	Test condition	Correct condition	Remark	
2K DT S 10-00	○		1-2 switch (MT)	1st position	ON	Ignition switch ON	
				Other	OFF		
			EC-AT CU (AT)	2nd or 3rd position	OFF	While running	
				Other	ON		
2L DT S 10-00	○		1-2 switch (MT)	2nd position	ON	Ignition switch ON	
				Other	OFF		
			EC-AT CU (AT)	3rd or 0/D position	OFF	While running	
				Other	ON		
3A DT S 10-00	○		Metering Oil pump position sensor	Ignition switch ON	1.0-4.2V	Voltage increase while accelerating	
				Idle	Approx. 1.1V		
				Accelerator pedal depressed	1.1-4.2V		
3B DT S 10-00	○		E/L unit	Headlight switch position I, II	ON		
				Blower motor position III, IV	ON		
				Rear defroster switch ON	ON		
				Headlight switch, Blower motor, rear defroster switch are OFF	OFF		
3C DT S 10-00	○		Oxygen sensor	Idle	Cold engine	Approx. 0V	
					After warm up	0.0-1.0V	
				Oscilloscope			
				Acceleration (After warm up)	0.5-1.0V		
				Deceleration (After warm up)	0.0-0.4V		
				3D DT S 10-00		○	
Electrical cooling fan does not operate	ON						
3E DT S 10-00	○		Water thermosensor	Engine coolant temperature 20°C	20°C	Ignition switch ON	
				Engine coolant temperature 60°C	60°C		
3F DT S 10-00	○		Throttle sensor (Narrow range)	Accelerator pedal released	0.75-1.25V	● Ignition switch ON ● After warm-up	
				Accelerator pedal fully depressed	4.8-5.0V		
3G DT S 10-00	○		Throttle sensor (full range)	Accelerator pedal released	0.1-0.7V	● Ignition switch ON ● After warm-up	
				Accelerator pedal fully depressed	4.2-4.6V		
3H DT S 10-00		○	Solenoid valve (purge control)	Idle	0 %		
				Engine speed 1,500-3,300 rpm	5-70 % (Reference)		While running

CONTROL SYSTEM

F

V_B: Battery voltage

Incorrect condition	Possible cause
Always OFF	<ul style="list-style-type: none"> ● Open circuit in wiring from 1-2 switch to ECU terminal 2K ● 1-2 switch malfunction (Refer to page F-187)
Always ON	<ul style="list-style-type: none"> ● Short circuit in wiring from 1-2 switch to ECU terminal 2K ● 1-2 switch malfunction (Refer to page F-187)
Always ON	Short circuit in wiring from EC-AT CU terminal 1D to ECU terminal 2K
Always OFF	Open circuit in wiring from EC-AT CU terminal 1D to ECU terminal 2K
Always ON	<ul style="list-style-type: none"> ● Short circuit in wiring from 1-2 switch to ECU terminal 2L ● 1-2 switch malfunction (Refer to page F-187)
Always OFF	<ul style="list-style-type: none"> ● Open circuit in wiring from 1-2 switch to ECU terminal 2L ● 1-2 switch malfunction (Refer to page F-187)
Always ON	Short circuit in wiring from EC-AT CU terminal 1B to ECU terminal 2L
Always OFF	Open circuit in wiring from EC-AT CU terminal 1B to ECU terminal 2L
Always approx. 0V or approx 5V	Refer to Code No.27 Troubleshooting (Refer to page F-43)
Always ON	<ul style="list-style-type: none"> ● Short circuit in wiring from switches ~ E/L unit ECU terminal 3B ● Switch malfunction (Refer to Section T)
Always OFF	<ul style="list-style-type: none"> ● Open circuit in wiring from switches ~ E/L unit ~ ECU terminal 3B ● Switch malfunction (Refer to Section T)
0V after warm up	Refer to Code No.15 Troubleshooting (Refer to page F-34)
Always approx. 1V after warm up	Refer to Code No.17 Troubleshooting (Refer to page F-36)
Always ON or OFF	<ul style="list-style-type: none"> ● Open or short circuit in wiring from cooling fan relay to ECU terminals 3D ● Fan relay malfunction (Refer to page F-147) ● ECU malfunction
Different temperature	Refer to Code No.09 Troubleshooting (Refer to page F-30)
Always approx. 0V	Refer to Code No.12 Troubleshooting (Refer to page F-32)
Always approx. 5V	
Always approx. 0V	Refer to Code No.18 Troubleshooting (Refer to page F-38)
Always approx. 5V	
Always duty valve not change	Refer to Code No.40 Troubleshooting (Refer to page F-53)

F

CONTROL SYSTEM

V_B: Battery voltage

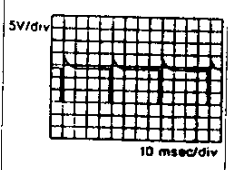
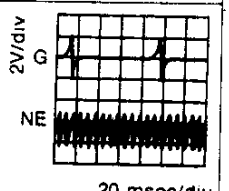
Terminal	Input	Output	Connected to	Test condition	Correct condition	Remark	
3I	○		Throttle sensor	Constant	Approx. 5.0V	Ignition switch ON	
3J DT S 1001	○		EGR switch	EGR valve operates	ON	California only	
				EGR valve does not operate	OFF		
	○		DRL relay	Idle	Pull the parking brake (Turnlight OFF)	OFF	Canada only
					Release the parking brake (Turnlight ON)	ON	
3K DT S 1003		○	Solenoid valve (Relief2)	Ignition switch ON	OFF		
				Idle	Before warm up approx. 40°C {104°F}		ON
					After warm up		OFF
3L DT S 1004	○		Intake air thermosensor	Ambient air temperature 20°C {68°F}	20°C	Ignition switch ON	
3M	○		Knock sensor	Ignition switch ON	Approx. 2.5V	Ignition switch ON	
				Knocking occur (Tap the engine hanger with hammer)	2.6-2.8V (Reference)		
3N DT S 1005		○	Solenoid valve (Port air by-pass)	Ignition switch ON	OFF	While running	
				After warm up Engine speed: 1,500-3,000 rpm	ON		
3O DT S 1006		○	Solenoid valve (Double throttle control)	Engine coolant temperature below 80°C {176°F}	ON	Ignition switch ON	
				After warm up	OFF		
3P DT S 1007		○	Solenoid valve (Relief1)	Idle	OFF	● After warm-up ● While running	
				Engine speed: 2,700-3,200 rpm	ON		
4A	-	-	Ground (Output)	Constant	0V	-	
4B	-	-	Ground (Output)	Constant	0V	-	
4C	-	-	Ground (CPU)	Constant	0V	-	
4D	-	-	Ground (Input)	Constant	0V	-	
4E DT S 1008	○		Crank angle sensor [NE + signal]	Idle	700-750 rpm		
				Oscilloscope			
							
4F DT S 1009		○	Solenoid valve (Split air by-pass)	Idle	OFF	● After warm up ● While running	
				5th position (MT), OD (AT)	ON		
4G	○		Crank angle sensor [G signal]	Ignition switch ON	Below 1.0V		
				Idle	Oscilloscope		
				Voltmeter			0.1-0.4V (Reference)

V_B : Battery voltage

Incorrect condition	Possible cause
Always 0V	<ul style="list-style-type: none"> ● Short circuit in wiring from main relay to ECU terminal 3I ● Main relay malfunction (Refer to page F-188)
Always ON or OFF	<ul style="list-style-type: none"> ● EGR switch malfunction (Refer to page F-127) ● Open or short circuit in wiring from EGR switch to ECU terminal 3J
Always ON or OFF	<ul style="list-style-type: none"> ● DRL relay malfunction (Refer to section T) ● Open or short circuit in wiring from DRL relay to ECU terminal 3J
Always ON or OFF	Refer to Code No.39 Troubleshooting (Refer to page F-52)
Different temperature	Refer to Code No.11 Troubleshooting (Refer to page F-31)
Always 0V	Refer to Code No.05 Troubleshooting (Refer to page F-28)
Always ON or OFF	Refer to Code No.33 Troubleshooting (Refer to page F-48)
Always ON or OFF	Refer to Code No.50 Troubleshooting (Refer to page F-59)
Always ON or OFF	Refer to Code No.31 Troubleshooting (Refer to page F-46)
Above 0V	<ul style="list-style-type: none"> ● Poor connection at ground terminal ● Open circuit in wiring from ECU
Always 229 rpm	Refer to Code No.03 Troubleshooting (Refer to page F-27)
Always ON or OFF	Refer to Code No.30 Troubleshooting (Refer to page F-45)
Always approx. 0V or approx. 5V	Refer to Code No.02 Troubleshooting (Refer to page F-26)

F

CONTROL SYSTEM

V_B: Battery voltage

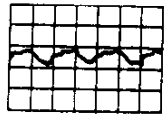
Terminal	Input	Output	Connected to	Test condition	Correct condition	Remark
4H	○		Crank angle sensor	Constant	below 1.0V	
4I		○	Stepping motor (Metering oil pump)	Ignition switch ON	V _B	
4J		Idle		3 terminals / 4 terminals V _B Other terminal 5-9V		
4K						
4L						
4M DT S 1990		○	Solenoid valve (Pressure regulator control)	Idle	OFF	approx. 1 minute
				Idle after hot start	ON	
4N DT S 1990		○	Solenoid valve (Switching)	Ignition switch ON/Idle	OFF	Initial acceleration
				Engine speed: above 3,200 rpm (After warm up)	ON	
4O DT S 1990		○	Solenoid valve (EGR)	Idle	OFF	While running
				5th position (MT)/OD (AT)	ON	
4P DT S 1990		○	Solenoid valve (AWS)	Before warm up approx. 40°C (104°F)	ON	Idle
				After warm up	OFF	
4Q DT S 1990		○	Solenoid valve (ISC)	While cranking	99 %	No electrical load
				Idle after warm up	32-65 %	
				Oscilloscope	5V/div  20 msec/div	Reference valve ● Initial set 38 %
4R DT S 1990		○	Solenoid valve (Turbo control)	Idle	OFF	Initial acceleration
				Engine speed: above 5,500 rpm (MT)	ON	
				Engine speed: above 5,250 rpm (AT)		
4S DT S 1990		○	Solenoid valve (charge relief)	Idle	OFF	Initial acceleration
				Engine speed: 4,000-5,500 rpm (MT) for 8 sec. 3,500-5,000 (AT) for 4 sec.	ON	
				Engine speed: above 5,500 rpm (MT) above 5,250 rpm (AT)		
4T DT S 1990		○	Solenoid valve (Charge control)	Idle	ON	Initial acceleration
				Engine speed: above 5,500 rpm (MT)	OFF	
				Engine speed: above 5,250 rpm (AT)		
4U DT S 1990		○	Solenoid valve (Wastegate control)	Idle	5 %	Reference valve ● Solenoid valve (Turbo control) before operates 95 %
				Initial acceleration	40-95 %	
				Oscilloscope		
4V DT S 1990		○	Solenoid valve (turbo pre-control)	Idle	5 %	Reference valve ● Solenoid valve (Turbo control) after operates 5 %
				Engine speed: above 3,000 rpm (Initial acceleration)	20-60 %	
				Oscilloscope		





V_B : Battery voltage

Incorrect condition	Possible cause
Always above 1.0V	Refer to Code No.02 Troubleshooting (Refer to page F-26)
Always 0V or V_B	Refer to Code No.26 Troubleshooting (Refer to page F-42)
Always ON or OFF	Refer to Code No.25 Troubleshooting (Refer to page F-41)
Always ON or OFF	Refer to Code No.32 Troubleshooting (Refer to page F-47)
Always ON or OFF	Refer to Code No.28 Troubleshooting (Refer to page F-44)
Always ON or OFF	Refer to Code No.38 Troubleshooting (Refer to page F-51)
Always duty value not change	Refer to Code No.34 Troubleshooting (Refer to page F-49)
Always ON or OFF	Refer to Code No.44 Troubleshooting (Refer to page F-56)
Always ON or OFF	Refer to Code No.46 Troubleshooting (Refer to page F-58)
Always ON or OFF	Refer to Code No.45 Troubleshooting (Refer to page F-57)
Always duty value not change	Refer to Code No.43 Troubleshooting (Refer to page F-55)
Always duty value not change	Refer to Code No.42 Troubleshooting (Refer to page F-54)

F

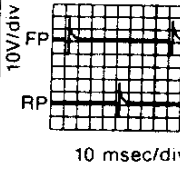
CONTROL SYSTEM

V_B: Battery voltage

Terminal	Input	Output	Connected to	Test condition	Correct condition	Remark
4W 		<input type="radio"/>	Injector (Front primary)	Idle* Oscilloscope	2.0-3.0 msec 	<ul style="list-style-type: none"> Secondary injection not working at no load condition Engine Signal Monitor: Green lamp flash
4X 		<input type="radio"/>	Injector (Front secondary)			
4Y 		<input type="radio"/>	Injector (Rear primary)			
4Z 		<input type="radio"/>	Injector (Rear secondary)			

16E0F2-19

Control Unit Connector (Control Unit Side)

4Y	4W	4U	4S	4Q	4O	4M	4K	4I	4G	4E	4C	4A	3D	3M	3K	3I	3G	3E	3C	3A	2K	2I	2G	2E	2C	2A	U	S	Q	O	M	K	I	G	E	C	A
4Z	4X	4V	4T	4R	4P	4N	4L	4J	4H	4F	4D	4B	3P	3N	3L	3J	3H	3F	3D	3B	2L	2J	2H	2F	2D	2B	V	T	R	P	N	L	J	H	F	D	B

V_B: Battery voltage

Incorrect condition	Possible cause
Different fuel injection amount	<ul style="list-style-type: none">● Open or short circuit in wiring from injector to ECU terminal 4W, 4X, 4Y, or 4Z● Main relay malfunction (Refer to page F-188)● Refer to troubleshooting

CRANK ANGLE SENSOR

Removal / Installation

1. Remove in the order shown in figure.
2. Install in the reverse order of removal, referring to **Installation Note**.

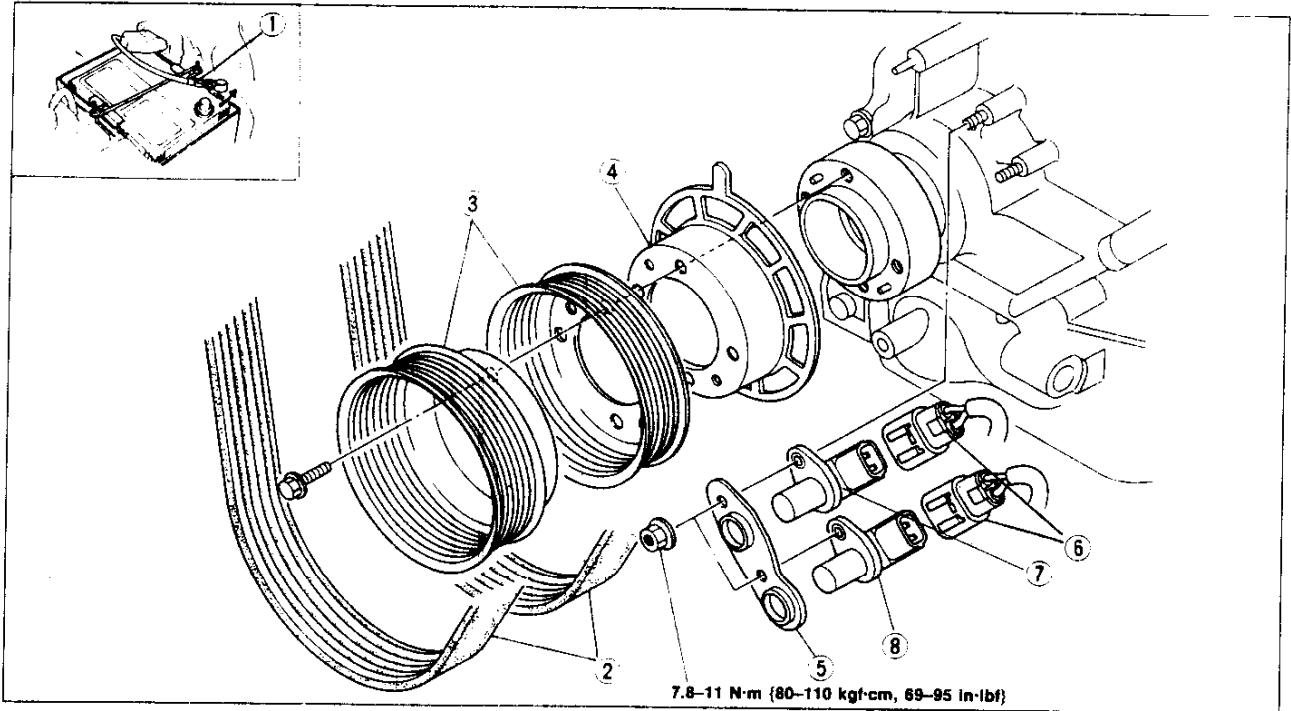

- | | |
|-----------------------------|---|
| 1. Battery cable | 6. Connectors |
| 2. Drive belt | 7. Crank angle sensor (NE-signal)
Inspection below |
| 3. Eccentric shaft pulley | 8. Crank angle sensor (G-signal)
Inspection below |
| 4. Crank angle sensor plate | |
| 5. Bracket | |

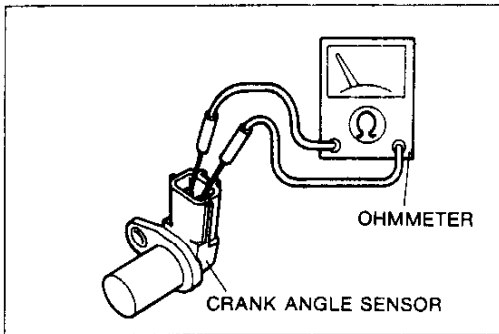

Inspection

1. Remove the crank angle sensor
 2. Measure the resistance of the sensor
- Resistance: 0.95–1.25 kΩ (20°C [68°F])**
3. If not as specified, replace the crank angle sensor.

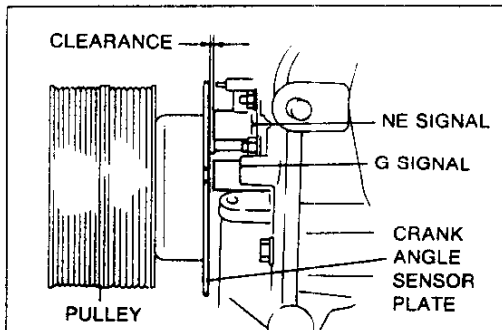

Installation Note

Measure the crank angle sensor to crank angle sensor plate clearance by using feeler gauge.

Clearance: 1.0–2.0 mm {0.039–0.078 in}

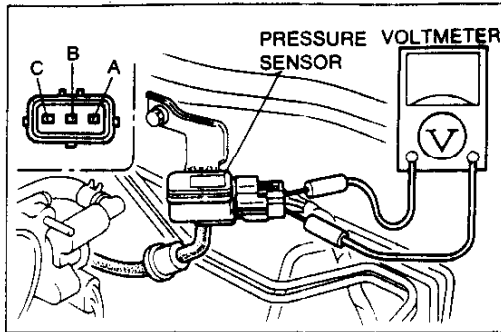
**PRESSURE SENSOR****Inspection**

1. Warm up the engine to normal operating temperature and run it at idle.
2. Turn all electrical load off.
3. Connect a voltmeter between the pressure sensor terminal A and B and verify the voltage is within specification.

Voltage: 1.3–1.6V

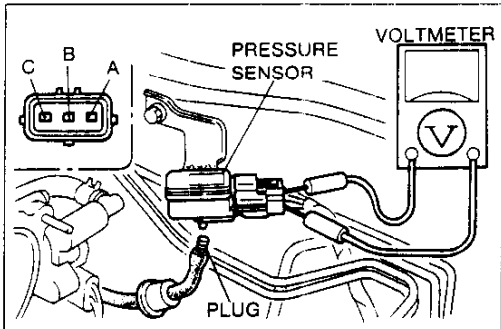

4. Disconnect vacuum tube and plug the vacuum tube and verify the voltage is within specification.

Voltage: 2.38–2.78V

5. Connect a vacuum pump to the pressure sensor.
6. Apply vacuum and measure the voltage of the pressure sensor

Vacuum	Voltage
-66 kPa (-500 mmHg, -19.7 inHg)	1.25–1.55V
0 kPa (0 mmHg, 0 inHg)	2.38–2.78V
98.7 kPa (740 mmHg, 29.1 inHg)	4.35–4.65V

7. If not as specified, replace the pressure sensor.
8. Cancel the memory of malfunctions by disconnecting the negative battery cable for at least 20 seconds and depress brake pedal.
9. Reconnect the negative battery cable.

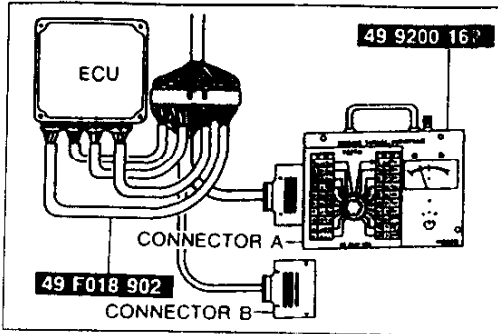

THROTTLE SENSOR
Inspection

1. Warm up the engine to normal operating temperature and run it at idle.
2. Verify the first idle cam separates.
3. Stop the engine.
4. Connect the **SSTs** (Engine Signal Monitor and Adaptor Harness) to ECU or connect the **SSTs** (DT-S1000 and Harness) to diagnosis connector as shown.
5. Turn the ignition switch to ON.
6. Rotate the throttle link by hand verify that the voltage is within specification.

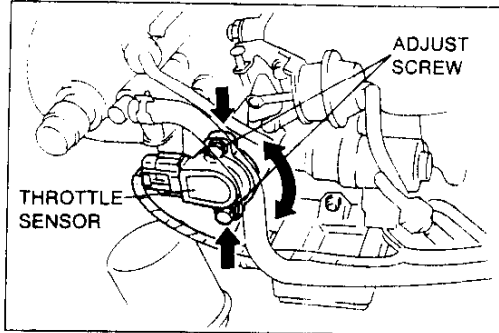

Specification

ECU Terminal	Throttle valve condition		
	Fully closed	closed to open	Fully open
3F (Narrow range)	0.75-1.25V	1.0-5.0V	4.8-5.0V
3G (Full range)	0.1-0.7V	0.4-4.3V	4.2-4.6V

7. If not as specified, adjust or replace the throttle sensor.

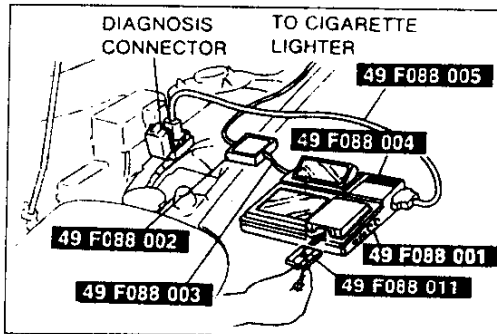

Adjustment

1. Warm up the engine to normal operating temperature and run it idle.
2. Verify that the first idle cam separates.
3. Stop the engine.
4. Connect the **SSTs** (Engine Signal Monitor and Adaptor Harness) to ECU or connect the **SSTs** (DT-S1000 and Harness) to diagnosis connector as shown.
5. Turn the ignition switch to ON.

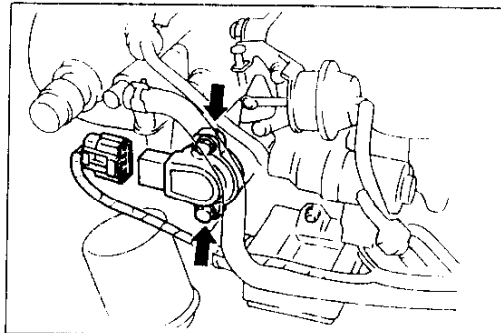

6. Loosen the screws and rotate the throttle sensor to set the correct closed position voltage.
(Refer to "Specification" above)
7. Check the correct open position voltage and close to open voltage.
(Refer to "Specification" above)
9. Tighten the screws.

Note

- When installing the sensor, Tighten to the specified torque.

Tightening Torque

1.6-2.4 N·m {16-24 kgf·cm, 140-210 in·lbf}

10. Cancel the memory of malfunctions by disconnecting the negative battery cable for at least 20 seconds and depress the brake pedal.
11. Reconnect the negative battery cable.

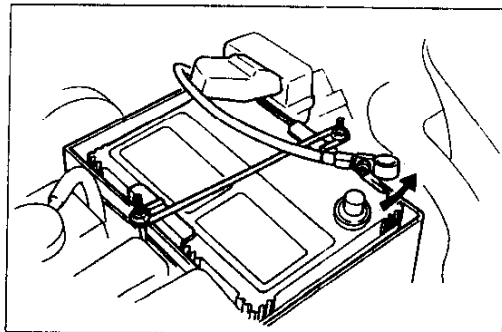

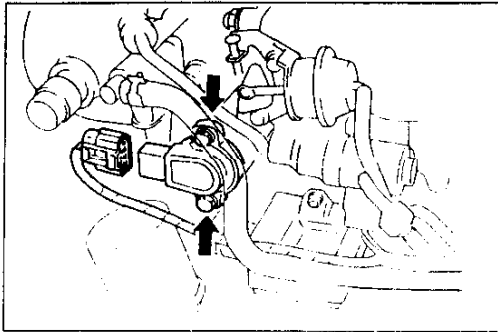

Removal / Installation

1. Turn ignition switch to OFF.
2. Disconnect the throttle sensor connector.
3. Remove the throttle sensor.

Caution

- Do not drop the throttle sensor.

4. Adjust the throttle sensor (Refer to page F-182)

WATER THERMOSENSOR

Removal / Installation

Warning

- Never remove water thermosensor while the engine is hot.

1. Remove the extension manifold. (Refer to page F-76).
2. Disconnect water thermosensor connector.
3. Remove the water thermosensor.
4. Install a new gasket and install in the reverse order of removal.

Note

- When installing the sensor, tighten to the specified torque.

Tightening torque:

19.6–24.5 N·m {200–250 kgf·cm, 174–217 in·lbf}

Inspection

1. Place the water thermosensor in water with a thermometer and heat the water gradually.
2. Measure the resistance of the sensor with an ohm meter.

Water temperature	Resistance
20°C (68°F)	2.2–2.7 kΩ
80°C (176°F)	0.29–0.35 kΩ

3. Replace the sensor, if necessary.

INTAKE AIR THERMOSENSOR

Removal / Installation

1. Remove the extension manifold (Refer to page F-76)
2. Remove the intake air thermosensor from extension manifold.

Note

- When installing the sensor, tighten to the specified torque.

Tightening torque:

7.8–12 N·m {0.8–1.2 kgf·m, 5.8–8.7 ft·lbf}

Inspection

1. Remove the intake air thermosensor and heat the sensor as shown in figure.
2. Measure the resistance of the sensor with an ohmmeter

Temperature	Resistance
20°C (68°F)	2.2–2.7 kΩ
80°C (176°F)	0.29–0.35 kΩ

3. Replace the sensor, if necessary.

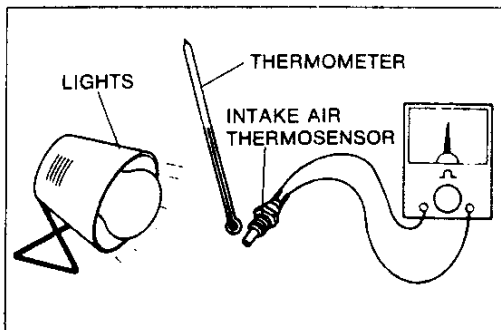
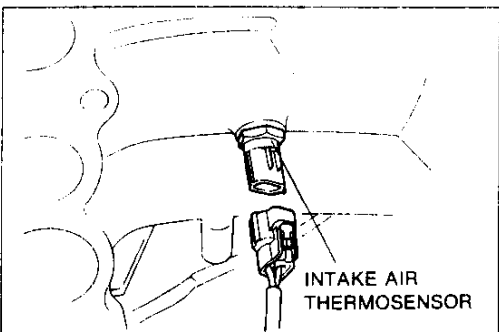
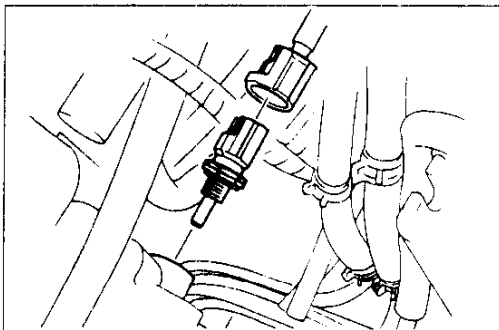
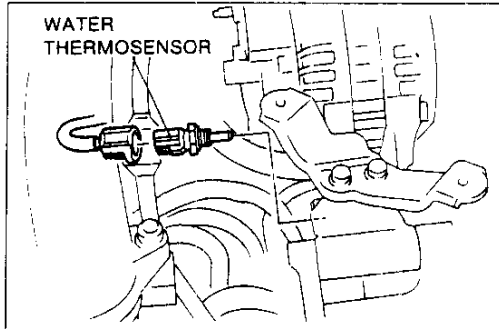

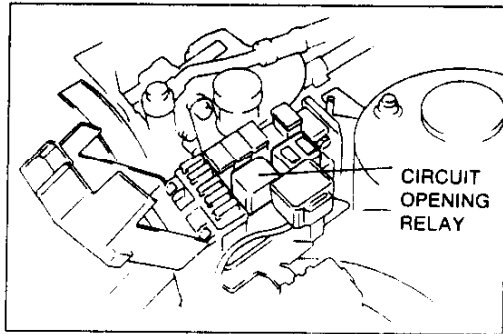

FUEL THERMOSENSOR

Removal / Installation

Warning

- Before performing the following operation, release the fuel pressure from the fuel system to reduce the possibility injury or fire (Refer to page F-95).

1. Remove the intake air system component parts. (Refer to page F-76)
2. Disconnect the fuel thermosensor connector.
3. Remove the fuel thermosensor.
4. Install in the reverse order of removal.

Note

- When installing the sensor, tighten to the specified torque.

Tightening torque:

19.6–24.5 N·m {200–250 kgf·cm, 174–217 in·lbf}

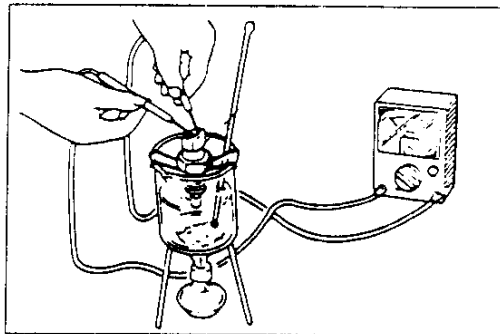
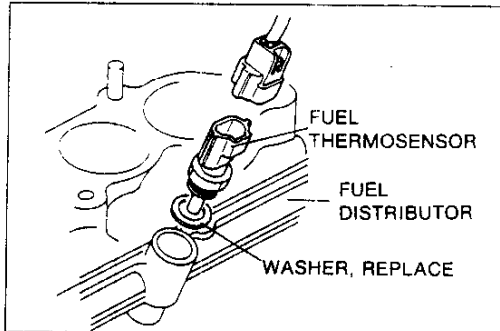

Inspection

1. Place the fuel thermosensor in water with a thermometer and heat the water gradually.
2. Measure the resistance of the sensor with an ohm meter.

Water temperature	Resistance
20°C {68°F}	2.2–2.7 kΩ
80°C {176°F}	0.29–0.35 kΩ

3. Replace the sensor, if necessary.

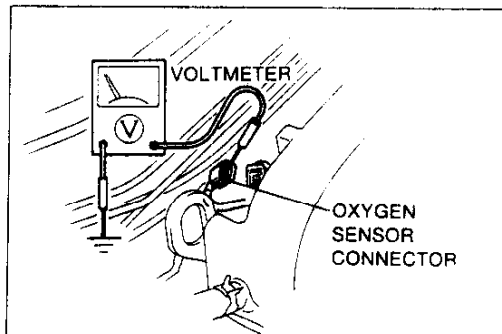

OXYGEN SENSOR

Inspection of Terminal Voltage.

1. Warm up the engine to normal operating temperature and run it at idle.
2. Disconnect the oxygen sensor connector.
3. Connect a voltmeter between the oxygen sensor terminal.

Caution

- When measuring the terminal voltage of oxygen sensor, use a high internal resistance type (More than 40 kΩ) voltmeter.

4. Measure the voltage while increasing and decreasing the engine speed suddenly several times.

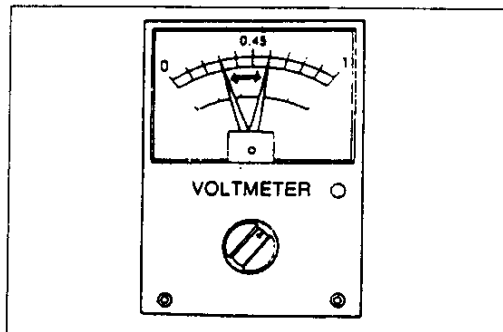

Specification

Engine condition	Voltage
While decelerating	0.0–0.4V
While accelerating	0.5–1.0V

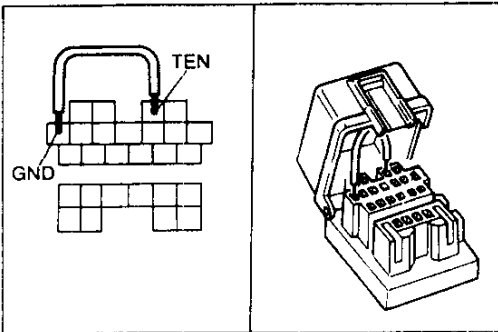
**KNOCK SENSOR****Inspection (On vehicle)**

1. Turn the ignition switch to ON.
2. Connect a voltmeter to the MEN terminal of the diagnosis connector
3. Connect the diagnosis connector terminals TEN and GND by using a jumper wire.
4. Turn ignition switch ON

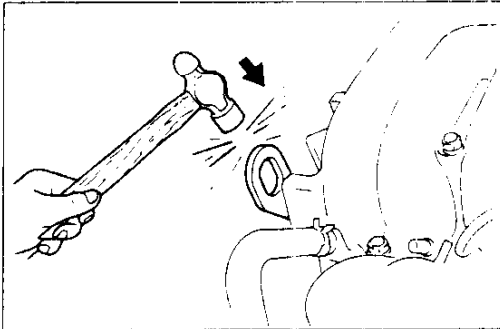

5. Lightly tap the engine hanger with a hammer.
6. Verify that the voltmeter indicator move.

Note

- When inspect again, turn ignition switch OFF.

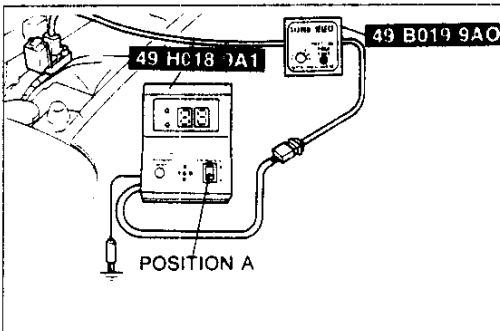
**Self Diagnosis Checker**

1. Connect the **SSTs** (System selector and Self-Diagnosis Checker) to diagnosis connector.
2. Set switch A to position of Self-Diagnosis Checker
3. Set SYSTEM SELECT position 1 and TEST SW to SELF-TEST of System selector.
4. Turn ignition switch ON
5. Lightly tap the engine hanger with a hammer.
6. Verify that the monitor lamp illuminates for approx. 0.5 seconds.

Note

- When inspect again, turn ignition switch OFF.

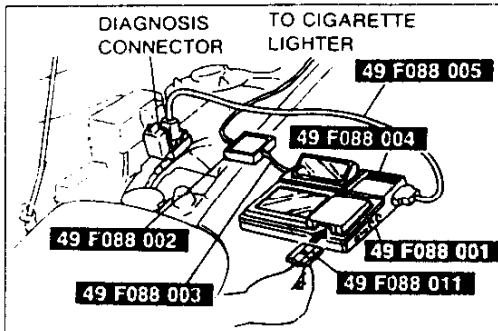
**DT-S1000**

1. Connect the **SSTs** (DT-S1000 and Harness) to diagnosis connector.
2. Select Switch Monitor function.
3. Turn ignition switch ON.
4. Lightly tap the engine hanger with a hammer.
5. Verify that the indicator, turn white to black for approx 0.5 seconds.

Note

- When inspect again, turn ignition switch OFF.

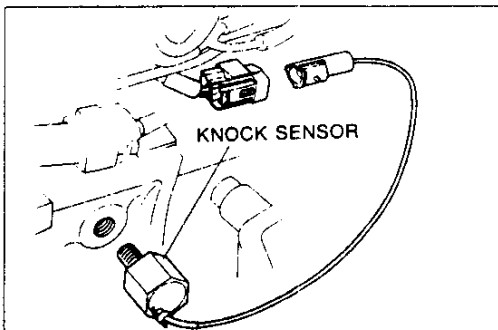
**Removal / Installation**

1. Disconnect knock sensor connector.
2. Remove the knock sensor.
3. Install in the reverse order of removal.

Tightening Torque:

20-34 N·m {2.0-3.5 kgf·m, 14-25 ft·lbf}

Caution

- Do not use a impact wrench.
- Do not drop the knock sensor.

F

CONTROL SYSTEM

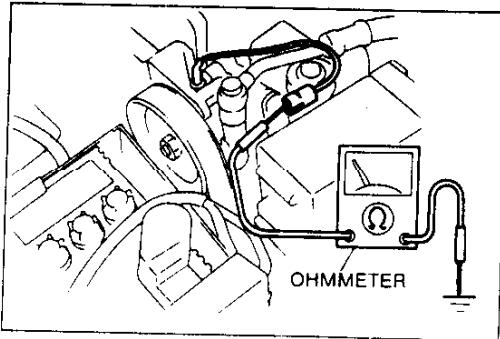

POWER STEERING PRESSURE SWITCH

Inspection (On the vehicle)

1. Disconnect the P/S pressure switch connector.
2. Start the engine, and check continuity of the switch.

Steering wheel	Continuity
Turned	Yes
Straight ahead	No

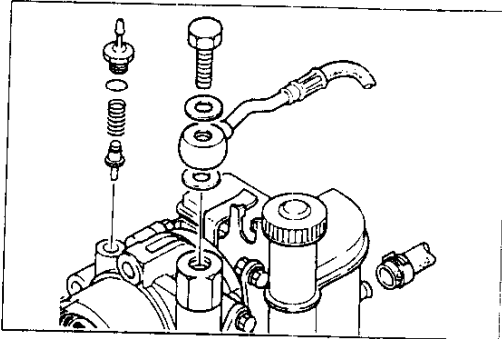

3. Replace the P/S pressure switch if not as specified

Note

- When installing the switch, tighten to the specified torque.

Tightening torque:

29–39 N·m {3.0–4.0 kgf·m, 22–29 ft·lbf}

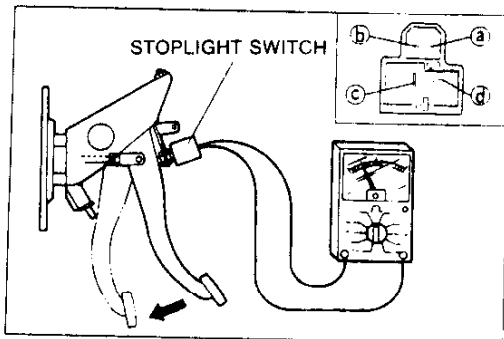

STOPLIGHT SWITCH

Inspection

1. Disconnect the stop light switch connector.
2. Connect a circuit tester between the stop light switch terminal C and D.
3. Check the continuity of the switch.

Pedal	Continuity
Depressed	Yes
Released	No

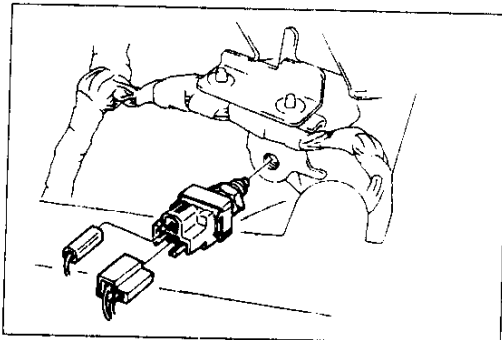

Removal / Installation

1. Disconnect the stoplight switch connector.
2. Remove the stoplight switch.
3. Install the stoplight switch.
4. Connect a circuit tester between the stoplight switch terminal C and D, and verify that the continuity when the brake pedal depressed and no continuity when the brake pedal released.
5. Tighten the adjust nut.

Tightening Torque:

14–18 N·m {1.4–1.8 kgf·m, 10–13 ft·lbf}

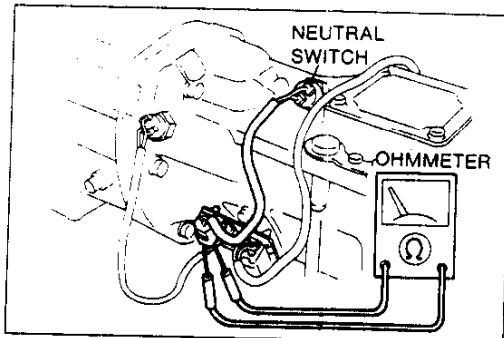

NEUTRAL SWITCH (MT)

Inspection

1. Disconnect the neutral switch connector.
2. Connect a circuit tester to the switch.
3. Check the continuity.

Transmission	Continuity
In neutral	Yes
In other ranges	No

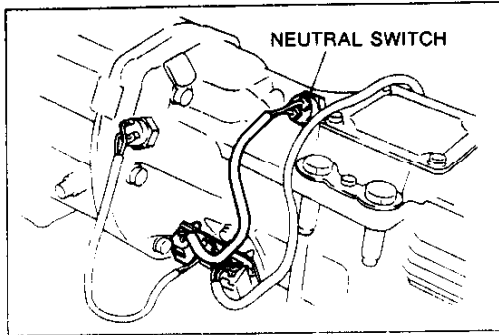

Removal / Installation

1. Remove the extension housing (Refer to Section J).
2. Disconnect the neutral switch connector.
3. Remove the neutral switch.
4. Install in the reverse order of removal.

Note

- When installing the switch tighten to the specified torque.

Tightening Torque:

25–34 N·m {2.5–3.5 kgf·m, 18–25 ft·lbf}

CLUTCH SWITCH (MT)

Inspection

1. Disconnect the clutch switch connector.
2. Connect a circuit tester to the switch.
3. Check the continuity.

Pedal	Continuity
Depressed	Yes
Released	No

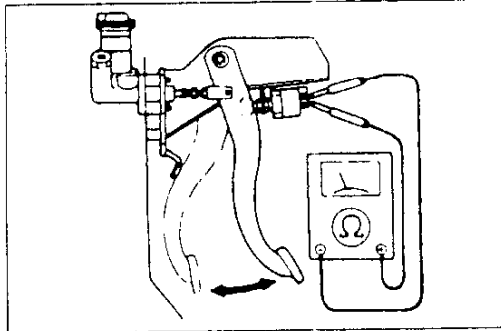

Removal / Installation

1. Remove the extension housing (Refer to Section J).
2. Remove the clutch switch.
3. Install the clutch switch.
4. Connect a circuit tester to the switch and verify that there is continuity when the clutch pedal is depressed and no continuity when the clutch pedal is released.
5. Tighten the adjust nut.

Tightening torque:

14–18 N·m {1.4–1.8 kgf·m 10–13 ft·lbf}

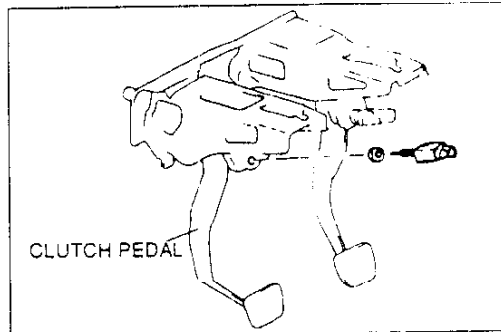

1-2 SWITCH (MT)

Inspection

1. Disconnect 1-2 switch.
2. Connect a circuit tester to the switch.
3. Check the continuity.

Terminal	Transmission	Continuity
A-B	In 1st range	No
	In other range	Yes
C-D	In 2nd	Yes
	In other range	No

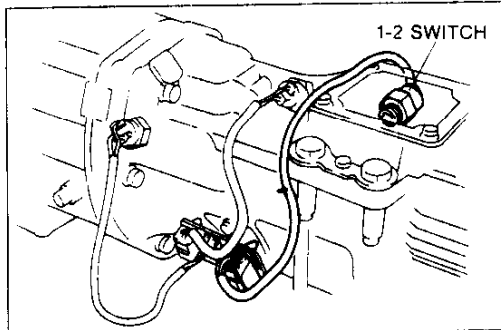
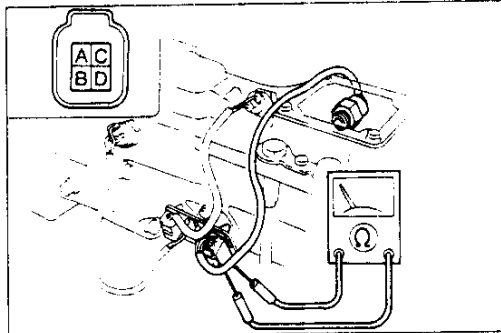

Removal / Installation

1. Remove the extension housing (Refer to Section J).
2. Remove the 1-2 switch.
3. Install in the reverse order of removal.

Note

- When installing the switch tighten to the specified torque.

Tightening torque:

25–34 N·m {2.5–3.5 kgf·m, 18–25 ft·lbf}

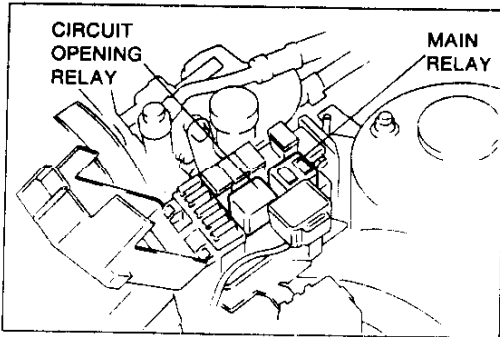

MAIN RELAY (EGI RELAY)

Inspection (On vehicle)

Check that a "clicking" sound is heard at the EGI main relay when turning the ignition switch OFF and ON

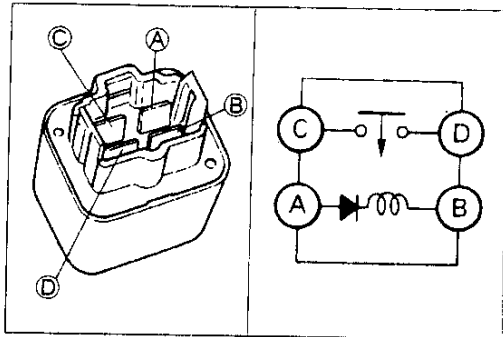

Inspection

1. Disconnect the main relay
2. Apply Battery voltage and ground to terminals A and B of the EGI main relay.
3. Check continuity of the relay.

Operation	C-D terminals
V _B Applied	Continuity
V _B Not applied	No continuity

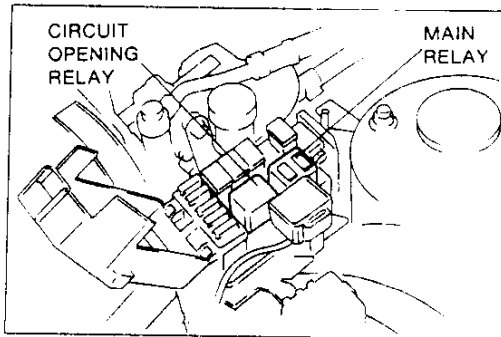

CIRCUIT OPENING RELAY

Inspection (On vehicle)

Check that a "clicking" sound is heard at the circuit opening relay, when turning the ignition switch OFF and ON.

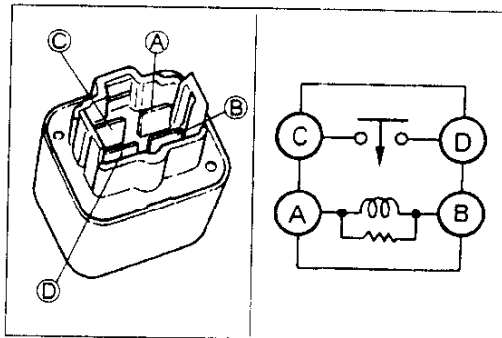

Inspection

1. Disconnect the circuit opening relay.
2. Apply battery voltage and ground to terminal A and B of the circuit opening relay.
3. Check continuity of the relay.

Operation	C-D terminals
V _E applied	Continuity
V _B Not applied	No continuity

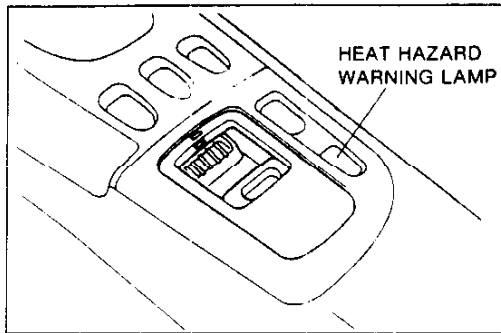

97U0F2 203

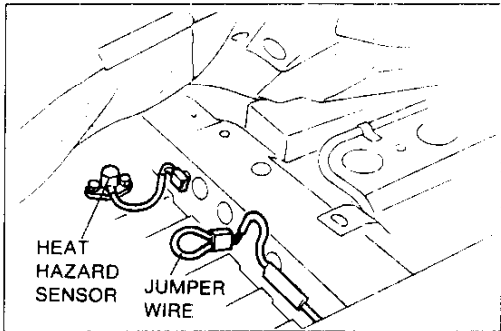

97U0F2 204

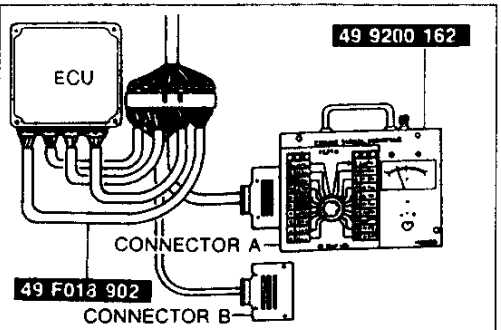
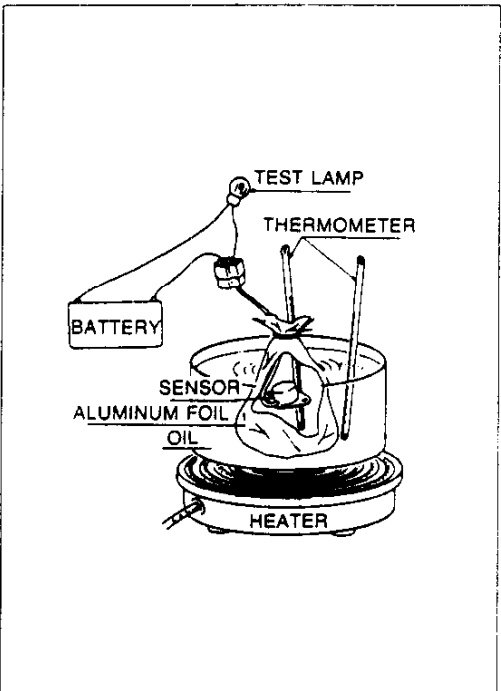

HEAT HAZARD SENSOR

Inspection (Warning system)

1. Turn the ignition switch ON. Verify that the heat hazard warning lamp illuminates.
2. Start the engine and verify that the warning lamp goes out.
3. Disconnect the heat hazard sensor connector.
4. Check that the heat hazard warning lamp illuminates on when a jumper wire is connected to the terminals of the sensor connector (harness side).

Removal

1. Remove right front seat.
2. Lift up the floor mat.
3. Disconnect the heat hazard sensor connector and remove the sensor.

Installation

Install in the reverse order of removal.

Inspection

1. Wrap the sensor and a thermometer in aluminum foil and place them in a container of oil.
2. Connect a test lamp and 12V to the terminals of the sensor connector.
3. Gradually heat the oil. Verify that the test lamp comes on when the temperature in the aluminum foil reaches 105–115°C {221–239°F}.

Caution

- Do not heat the oil to more than 150°C {302°F}.

4. Replace the sensor, if necessary.

MILEAGE SWITCH

Inspection

1. Connect the **SST** (Engine Signal Monitor) to the ECU.
2. Turn ignition switch ON.
3. Check the ECU terminal 1N as show.

Under 20,000 miles	Below 1.5V
Over 20,000 miles	V _e

Note

- When checking the terminal voltage, measure the during two second after ignition switch ON.

SOLENOID VALVES

Removal / Installation

1. Remove in the order shown in the figure.
2. Install in the reverse order of removal.

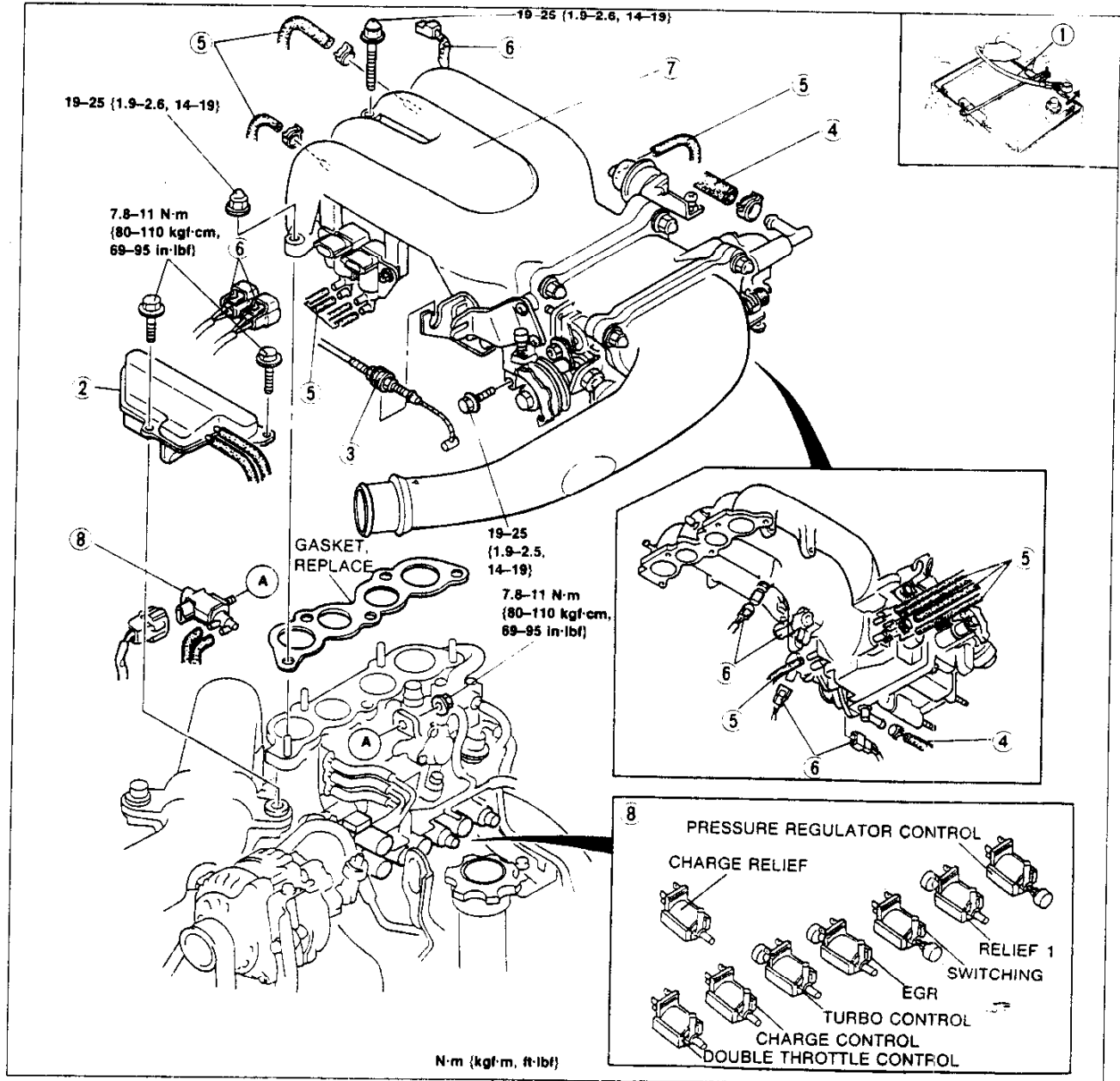

1. Battery cable
2. Pressure chamber
3. Accelerator cable
removal / installation page F-80
inspection / adjustment page F-80
4. Water hose
5. Vacuum hoses

6. Connector
7. Extension manifold
8. Solenoid valves
inspection page F-12

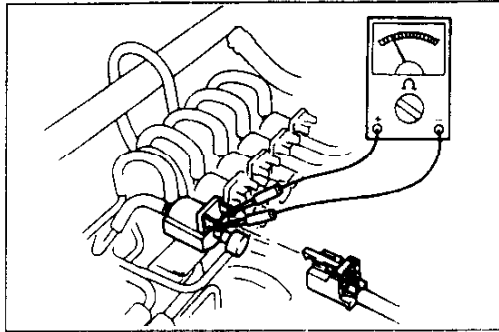

Inspection

1. Disconnect the connector.
2. Connect a circuit tester to the solenoid valve.
3. Check the continuity at the terminals.

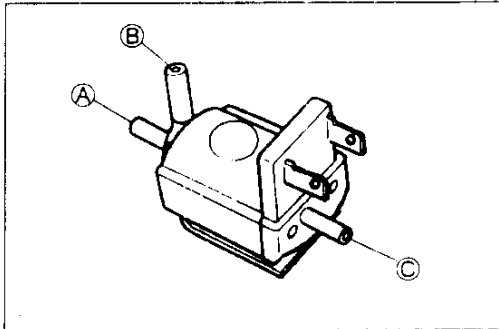

4. Verify that air flows between each ports as below.

Port	Air flow
A-B	No
A-C	No
B-C	Yes

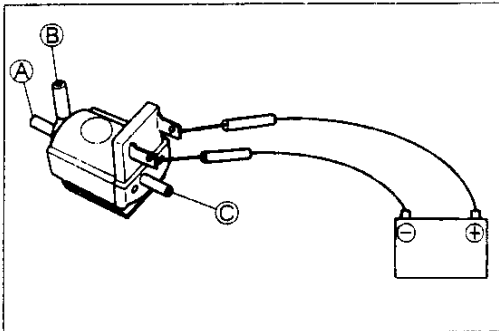

5. Connect V_B and a ground to the terminals of the solenoid valve.

6. Verify that air flows between each ports as below.

Port	Air flow
A-B	Yes
A-C	No
B-C	No

7. Replace the solenoid valve, if necessary.

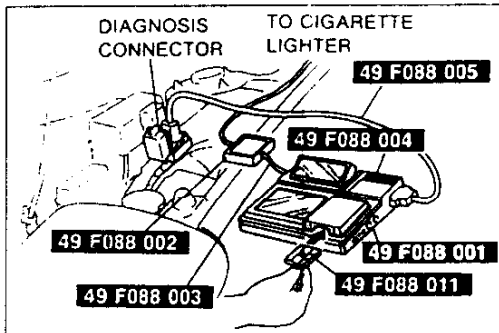

DT-S1000

1. Connect the **SST** (DT-1000) between the diagnosis connector and the wiring harness by using the **SST** (Harness).
2. Turn the ignition switch to ON.
3. Select the simulation function.
4. Listen for operational sounds of each solenoid valve.
5. If no sound is heard, check the wiring to the solenoid valves and measure the voltage of the ECU terminals. (Refer to page F-152).

F

TROUBLESHOOTING GUIDE

TROUBLESHOOTING GUIDE

QUICK DIAGNOSIS CHART

This Quick Diagnosis Chart shows the relationship between troubleshooting items and inspection points.

Possible parts and reference page		Item	Intake air system		Fuel system					Ignition system			Turbo charger system		Secondary air injection system			Emission system		
			F-16 F-83 F-83 F-137 F-79 F-76	F-105 F-105 F-103 F-100	F-110 F-109 F-110 F-104 F-112	Section G Section G Section G	F-16	F-93 F-93 F-93 F-93 F-123 F-119 F-119 F-119 F-123 F-121 F-123	F-123 F-119 F-119 F-123 F-121 F-123	F-128 F-131 F-131 F-127	F-127									
		1	Melts main or other fuse																	
		2	Will not crank or cranks slowly																	
		3	Crank normally but will not start	No combustion																
		4		Partial combustion—when engine cold																
		5		Partial combustion—after warm-up																
		7	Crank normally but hard to start	Any engine temp.																
		8		When engine cold																
		9		After warm-up																
		10	Engine stalls	Idle at any engine temp																
		11		During fast idle																
		12		Idle after warm-up																
		13		Idle with A/C, P/S, and/or E/L ON																
		14		Idle when shifted from N or P to other ranges																
		15		Driveaway																
		16		On acceleration																
		17		While cruising																
		18	On deceleration																	
		19	Engine rough	Idle at any engine temp																
		20		During fast idle																
		21		Idle after warm-up																
		22		Idle with A/C, P/S, and/or E/L ON																
		23		Idle when shifted from N or P to other ranges																
		24		On deceleration																
		25	Poor acceleration	Driveaway																
		26		On acceleration																
		27	High idle speed after warm-up																	

F

TROUBLESHOOTING GUIDE

Item	Possible parts and reference page																																					
	Intake air system				Fuel system				Ignition system		Turbo charger system		Secondary air Injection system			Emission system																						
	F-16	F-83	F-83	F-137	F-79	F-76	F-105	F-105	F-103	F-100	F-110	F-109	F-110	F-104	F-112	Section G	Section G	Section G	F-16	F-93	F-93	F-93	F-93	F-123	F-119	F-119	F-119	F-119	F-123	F-21	F-123	F-128	F-131	F-131	F-127			
	Air cleaner element	Solenoid valve (ISC)	Solenoid valve (AWS)	Solenoid valve (Double throttle)	Fast idle cam	Intake air leakage	Injector (Primary)	Injector (Secondary)	Fuel filter	Fuel pump	Fuel pump relay	Fuel pump resistor	Circuit opening relay	Pressure regulator	Solenoid valve (PRC)	Igniter	Ignition coil	Spark plug	Ignition timing	Turbo precontrol	Wastegate control	Turbo control	Charge control	Charge relief	Relief 1	Switching	Split air bypass	Port air bypass	Relief 2	Air pump	Air pump relay	Catalytic converter	Charcoal canister	Solenoid valve (Purge control)	Solenoid valve (EGR)			
28 Idle fluctuates / idle hunts	<input type="checkbox"/>	<input type="checkbox"/>				<input type="checkbox"/>	<input type="checkbox"/>	<input type="checkbox"/>		<input type="checkbox"/>						<input type="checkbox"/>	<input type="checkbox"/>	<input type="checkbox"/>	<input type="checkbox"/>																			
29 Hesitates / Stumbles on acceleration	<input type="checkbox"/>		<input type="checkbox"/>				<input type="checkbox"/>	<input type="checkbox"/>		<input type="checkbox"/>						<input type="checkbox"/>	<input type="checkbox"/>	<input type="checkbox"/>	<input type="checkbox"/>			<input type="checkbox"/>	<input type="checkbox"/>															
30 Surges while cruising							<input type="checkbox"/>	<input type="checkbox"/>		<input type="checkbox"/>						<input type="checkbox"/>	<input type="checkbox"/>	<input type="checkbox"/>	<input type="checkbox"/>			<input type="checkbox"/>	<input type="checkbox"/>															
31 Lack of power	<input type="checkbox"/>						<input type="checkbox"/>	<input type="checkbox"/>		<input type="checkbox"/>						<input type="checkbox"/>	<input type="checkbox"/>	<input type="checkbox"/>	<input type="checkbox"/>			<input type="checkbox"/>	<input type="checkbox"/>															
32 Poor fuel economy	<input type="checkbox"/>						<input type="checkbox"/>	<input type="checkbox"/>		<input type="checkbox"/>						<input type="checkbox"/>	<input type="checkbox"/>	<input type="checkbox"/>	<input type="checkbox"/>			<input type="checkbox"/>	<input type="checkbox"/>															
33 A/C does not work																																						
34 Knocking / Pinging						<input type="checkbox"/>	<input type="checkbox"/>																															
35 Fuel odor																																						
36 Exhaust sulfur smell																																						
37 High oil consumption																																						
38 Self-Diagnosis Checker flashes 88																																						
39 Self-Diagnosis Checker will not work																																						

TROUBLESHOOTING GUIDE

F

DECELERATION system	CONTROL SYSTEM (INPUT SIGNAL)	OTHERS	Possible parts and reference page
F-134	Dashpot		
F-77	Air bypass valve		
F-180	Crank angle sensor (NE)		
F-180	Crank angle sensor (G)		
F-183	Water thermostat		
F-183	Intake air thermostat		
F-184	Fuel thermostat		
F-181	Pressure sensor		
F-182	Narrow range Throttle sensor		
F-182	Fuel range		
F-184	Oxygen sensor		
F-185	Knock sensor		
Section T	Speedometer sensor		
Section D	Metering oil pump position sensor		
F-186	P/S pressure sensor		
Section U	A/C switch		
Section E	Water thermostat		
F-186	Stoplight switch		
F-189	Mileage switch		
F-187	Heat hazard sensor		
F-152	Starter signal		
F-134	E/L unit		
F-187	1-2 switch (MT)		
F-186	Neutral switch (MT)		
F-187	Clutch switch (MT)		
Section K	Solenoid valve (Shift A) (AT)		
Section K	Solenoid valve (Shift B) (AT)		
Section K	Reduce torque signal (AT)		
Section K	Slip lock-up signal (AT)		
Section K	Inhibitor signal (AT)		
Section E	Electrical cooling fan		
Section D	Metering oil pump		
F-143	A/C relay		
Section C	Compression down		
F-150	ECU		
			Item
			Idle fluctuates / idle hunts 28
			Hesitates / Stumbles on acceleration 29
			Surges while cruising 30
			Lack of power 31
			Poor fuel economy 32
			A/C does not work 33
			Knocking / Pinging 34
			Fuel odor 35
			Exhaust sulfur smell 36
			High oil consumption 37
			Self-Diagnosis Checker flashes 88 38
			Self-Diagnosis Checker will not work 39

RELATIONSHIP CHART

INPUT DEVICE		OUTPUT DEVICE		SOLENOID VALVE																						
		FUEL INJECTION AMOUNT	INJECTOR	IDLE SPEED CONTROL SYSTEM	ACCELERATED WARM-UP SYSTEM	DOUBLE THROTTLE CONTROL SYSTEM	PRESSURE REGULATOR CONTROL	TURBO PRECONTROL	WASTEGATE CONTROL	TURBO CONTROL	CHARGE CONTROL	CHARGE RELIEF	RELIEF 1	SWITCHING	SPLIT AIR BYPASS	PORT AIR BYPASS	RELIEF 2	PURGE CONTROL	EGR	EC-AT CONTROL UNIT	METERING OIL PUMP	A/C RELAY	AIR PUMP RELAY	SERVICE CODE	MONITOR LAMP	
CRANK ANGLE SENSOR	NE SIGNAL	<input type="checkbox"/>	<input type="checkbox"/>	<input type="checkbox"/>	<input type="checkbox"/>	<input type="checkbox"/>	<input type="checkbox"/>	<input type="checkbox"/>	<input type="checkbox"/>	<input type="checkbox"/>	<input type="checkbox"/>	<input type="checkbox"/>	<input type="checkbox"/>	<input type="checkbox"/>	<input type="checkbox"/>	<input type="checkbox"/>	<input type="checkbox"/>	<input type="checkbox"/>	<input type="checkbox"/>	<input type="checkbox"/>	<input type="checkbox"/>	<input type="checkbox"/>	<input type="checkbox"/>	<input type="checkbox"/>	<input type="checkbox"/>	<input type="checkbox"/>
	G SIGNAL	<input type="checkbox"/>	<input type="checkbox"/>	<input type="checkbox"/>	<input type="checkbox"/>	<input type="checkbox"/>	<input type="checkbox"/>	<input type="checkbox"/>	<input type="checkbox"/>	<input type="checkbox"/>	<input type="checkbox"/>	<input type="checkbox"/>	<input type="checkbox"/>	<input type="checkbox"/>	<input type="checkbox"/>	<input type="checkbox"/>	<input type="checkbox"/>	<input type="checkbox"/>	<input type="checkbox"/>	<input type="checkbox"/>	<input type="checkbox"/>	<input type="checkbox"/>	<input type="checkbox"/>	<input type="checkbox"/>	<input type="checkbox"/>	<input type="checkbox"/>
THROTTLE SENSOR	NARROW RANGE	<input type="checkbox"/>	<input type="checkbox"/>	<input type="checkbox"/>	<input type="checkbox"/>	<input type="checkbox"/>	<input type="checkbox"/>	<input type="checkbox"/>	<input type="checkbox"/>	<input type="checkbox"/>	<input type="checkbox"/>	<input type="checkbox"/>	<input type="checkbox"/>	<input type="checkbox"/>	<input type="checkbox"/>	<input type="checkbox"/>	<input type="checkbox"/>	<input type="checkbox"/>	<input type="checkbox"/>	<input type="checkbox"/>	<input type="checkbox"/>	<input type="checkbox"/>	<input type="checkbox"/>	<input type="checkbox"/>	<input type="checkbox"/>	<input type="checkbox"/>
	FULL RANGE	<input type="checkbox"/>	<input type="checkbox"/>	<input type="checkbox"/>	<input type="checkbox"/>	<input type="checkbox"/>	<input type="checkbox"/>	<input type="checkbox"/>	<input type="checkbox"/>	<input type="checkbox"/>	<input type="checkbox"/>	<input type="checkbox"/>	<input type="checkbox"/>	<input type="checkbox"/>	<input type="checkbox"/>	<input type="checkbox"/>	<input type="checkbox"/>	<input type="checkbox"/>	<input type="checkbox"/>	<input type="checkbox"/>	<input type="checkbox"/>	<input type="checkbox"/>	<input type="checkbox"/>	<input type="checkbox"/>	<input type="checkbox"/>	<input type="checkbox"/>
WATER THERMOSENSOR		<input type="checkbox"/>	<input type="checkbox"/>	<input type="checkbox"/>	<input type="checkbox"/>	<input type="checkbox"/>	<input type="checkbox"/>	<input type="checkbox"/>	<input type="checkbox"/>	<input type="checkbox"/>	<input type="checkbox"/>	<input type="checkbox"/>	<input type="checkbox"/>	<input type="checkbox"/>	<input type="checkbox"/>	<input type="checkbox"/>	<input type="checkbox"/>	<input type="checkbox"/>	<input type="checkbox"/>	<input type="checkbox"/>	<input type="checkbox"/>	<input type="checkbox"/>	<input type="checkbox"/>	<input type="checkbox"/>	<input type="checkbox"/>	<input type="checkbox"/>
INTAKE AIR THERMOSENSOR		<input type="checkbox"/>	<input type="checkbox"/>	<input type="checkbox"/>	<input type="checkbox"/>	<input type="checkbox"/>	<input type="checkbox"/>	<input type="checkbox"/>	<input type="checkbox"/>	<input type="checkbox"/>	<input type="checkbox"/>	<input type="checkbox"/>	<input type="checkbox"/>	<input type="checkbox"/>	<input type="checkbox"/>	<input type="checkbox"/>	<input type="checkbox"/>	<input type="checkbox"/>	<input type="checkbox"/>	<input type="checkbox"/>	<input type="checkbox"/>	<input type="checkbox"/>	<input type="checkbox"/>	<input type="checkbox"/>	<input type="checkbox"/>	<input type="checkbox"/>
FUEL THERMOSENSOR		<input type="checkbox"/>	<input type="checkbox"/>	<input type="checkbox"/>	<input type="checkbox"/>	<input type="checkbox"/>	<input type="checkbox"/>	<input type="checkbox"/>	<input type="checkbox"/>	<input type="checkbox"/>	<input type="checkbox"/>	<input type="checkbox"/>	<input type="checkbox"/>	<input type="checkbox"/>	<input type="checkbox"/>	<input type="checkbox"/>	<input type="checkbox"/>	<input type="checkbox"/>	<input type="checkbox"/>	<input type="checkbox"/>	<input type="checkbox"/>	<input type="checkbox"/>	<input type="checkbox"/>	<input type="checkbox"/>	<input type="checkbox"/>	<input type="checkbox"/>
PRESSURE SENSOR		<input type="checkbox"/>	<input type="checkbox"/>	<input type="checkbox"/>	<input type="checkbox"/>	<input type="checkbox"/>	<input type="checkbox"/>	<input type="checkbox"/>	<input type="checkbox"/>	<input type="checkbox"/>	<input type="checkbox"/>	<input type="checkbox"/>	<input type="checkbox"/>	<input type="checkbox"/>	<input type="checkbox"/>	<input type="checkbox"/>	<input type="checkbox"/>	<input type="checkbox"/>	<input type="checkbox"/>	<input type="checkbox"/>	<input type="checkbox"/>	<input type="checkbox"/>	<input type="checkbox"/>	<input type="checkbox"/>	<input type="checkbox"/>	<input type="checkbox"/>
OXYGEN SENSOR		<input type="checkbox"/>	<input type="checkbox"/>	<input type="checkbox"/>	<input type="checkbox"/>	<input type="checkbox"/>	<input type="checkbox"/>	<input type="checkbox"/>	<input type="checkbox"/>	<input type="checkbox"/>	<input type="checkbox"/>	<input type="checkbox"/>	<input type="checkbox"/>	<input type="checkbox"/>	<input type="checkbox"/>	<input type="checkbox"/>	<input type="checkbox"/>	<input type="checkbox"/>	<input type="checkbox"/>	<input type="checkbox"/>	<input type="checkbox"/>	<input type="checkbox"/>	<input type="checkbox"/>	<input type="checkbox"/>	<input type="checkbox"/>	<input type="checkbox"/>
KNOCK SENSOR		<input type="checkbox"/>	<input type="checkbox"/>	<input type="checkbox"/>	<input type="checkbox"/>	<input type="checkbox"/>	<input type="checkbox"/>	<input type="checkbox"/>	<input type="checkbox"/>	<input type="checkbox"/>	<input type="checkbox"/>	<input type="checkbox"/>	<input type="checkbox"/>	<input type="checkbox"/>	<input type="checkbox"/>	<input type="checkbox"/>	<input type="checkbox"/>	<input type="checkbox"/>	<input type="checkbox"/>	<input type="checkbox"/>	<input type="checkbox"/>	<input type="checkbox"/>	<input type="checkbox"/>	<input type="checkbox"/>	<input type="checkbox"/>	<input type="checkbox"/>
SPEEDOMETER SENSOR		<input type="checkbox"/>	<input type="checkbox"/>	<input type="checkbox"/>	<input type="checkbox"/>	<input type="checkbox"/>	<input type="checkbox"/>	<input type="checkbox"/>	<input type="checkbox"/>	<input type="checkbox"/>	<input type="checkbox"/>	<input type="checkbox"/>	<input type="checkbox"/>	<input type="checkbox"/>	<input type="checkbox"/>	<input type="checkbox"/>	<input type="checkbox"/>	<input type="checkbox"/>	<input type="checkbox"/>	<input type="checkbox"/>	<input type="checkbox"/>	<input type="checkbox"/>	<input type="checkbox"/>	<input type="checkbox"/>	<input type="checkbox"/>	<input type="checkbox"/>
MOP POSITION SENSOR		<input type="checkbox"/>	<input type="checkbox"/>	<input type="checkbox"/>	<input type="checkbox"/>	<input type="checkbox"/>	<input type="checkbox"/>	<input type="checkbox"/>	<input type="checkbox"/>	<input type="checkbox"/>	<input type="checkbox"/>	<input type="checkbox"/>	<input type="checkbox"/>	<input type="checkbox"/>	<input type="checkbox"/>	<input type="checkbox"/>	<input type="checkbox"/>	<input type="checkbox"/>	<input type="checkbox"/>	<input type="checkbox"/>	<input type="checkbox"/>	<input type="checkbox"/>	<input type="checkbox"/>	<input type="checkbox"/>	<input type="checkbox"/>	<input type="checkbox"/>
E/L UNIT		<input type="checkbox"/>	<input type="checkbox"/>	<input type="checkbox"/>	<input type="checkbox"/>	<input type="checkbox"/>	<input type="checkbox"/>	<input type="checkbox"/>	<input type="checkbox"/>	<input type="checkbox"/>	<input type="checkbox"/>	<input type="checkbox"/>	<input type="checkbox"/>	<input type="checkbox"/>	<input type="checkbox"/>	<input type="checkbox"/>	<input type="checkbox"/>	<input type="checkbox"/>	<input type="checkbox"/>	<input type="checkbox"/>	<input type="checkbox"/>	<input type="checkbox"/>	<input type="checkbox"/>	<input type="checkbox"/>	<input type="checkbox"/>	<input type="checkbox"/>
A/C SWITCH		<input type="checkbox"/>	<input type="checkbox"/>	<input type="checkbox"/>	<input type="checkbox"/>	<input type="checkbox"/>	<input type="checkbox"/>	<input type="checkbox"/>	<input type="checkbox"/>	<input type="checkbox"/>	<input type="checkbox"/>	<input type="checkbox"/>	<input type="checkbox"/>	<input type="checkbox"/>	<input type="checkbox"/>	<input type="checkbox"/>	<input type="checkbox"/>	<input type="checkbox"/>	<input type="checkbox"/>	<input type="checkbox"/>	<input type="checkbox"/>	<input type="checkbox"/>	<input type="checkbox"/>	<input type="checkbox"/>	<input type="checkbox"/>	<input type="checkbox"/>
P/S PRESSURE SWITCH		<input type="checkbox"/>	<input type="checkbox"/>	<input type="checkbox"/>	<input type="checkbox"/>	<input type="checkbox"/>	<input type="checkbox"/>	<input type="checkbox"/>	<input type="checkbox"/>	<input type="checkbox"/>	<input type="checkbox"/>	<input type="checkbox"/>	<input type="checkbox"/>	<input type="checkbox"/>	<input type="checkbox"/>	<input type="checkbox"/>	<input type="checkbox"/>	<input type="checkbox"/>	<input type="checkbox"/>	<input type="checkbox"/>	<input type="checkbox"/>	<input type="checkbox"/>	<input type="checkbox"/>	<input type="checkbox"/>	<input type="checkbox"/>	<input type="checkbox"/>
IGNITION SWITCH (ST SIGNAL)		<input type="checkbox"/>	<input type="checkbox"/>	<input type="checkbox"/>	<input type="checkbox"/>	<input type="checkbox"/>	<input type="checkbox"/>	<input type="checkbox"/>	<input type="checkbox"/>	<input type="checkbox"/>	<input type="checkbox"/>	<input type="checkbox"/>	<input type="checkbox"/>	<input type="checkbox"/>	<input type="checkbox"/>	<input type="checkbox"/>	<input type="checkbox"/>	<input type="checkbox"/>	<input type="checkbox"/>	<input type="checkbox"/>	<input type="checkbox"/>	<input type="checkbox"/>	<input type="checkbox"/>	<input type="checkbox"/>	<input type="checkbox"/>	<input type="checkbox"/>
STOPLIGHT SWITCH		<input type="checkbox"/>	<input type="checkbox"/>	<input type="checkbox"/>	<input type="checkbox"/>	<input type="checkbox"/>	<input type="checkbox"/>	<input type="checkbox"/>	<input type="checkbox"/>	<input type="checkbox"/>	<input type="checkbox"/>	<input type="checkbox"/>	<input type="checkbox"/>	<input type="checkbox"/>	<input type="checkbox"/>	<input type="checkbox"/>	<input type="checkbox"/>	<input type="checkbox"/>	<input type="checkbox"/>	<input type="checkbox"/>	<input type="checkbox"/>	<input type="checkbox"/>	<input type="checkbox"/>	<input type="checkbox"/>	<input type="checkbox"/>	<input type="checkbox"/>
NEUTRAL SWITCH (MT)		<input type="checkbox"/>	<input type="checkbox"/>	<input type="checkbox"/>	<input type="checkbox"/>	<input type="checkbox"/>	<input type="checkbox"/>	<input type="checkbox"/>	<input type="checkbox"/>	<input type="checkbox"/>	<input type="checkbox"/>	<input type="checkbox"/>	<input type="checkbox"/>	<input type="checkbox"/>	<input type="checkbox"/>	<input type="checkbox"/>	<input type="checkbox"/>	<input type="checkbox"/>	<input type="checkbox"/>	<input type="checkbox"/>	<input type="checkbox"/>	<input type="checkbox"/>	<input type="checkbox"/>	<input type="checkbox"/>	<input type="checkbox"/>	<input type="checkbox"/>
CLUTCH SWITCH (MT)		<input type="checkbox"/>	<input type="checkbox"/>	<input type="checkbox"/>	<input type="checkbox"/>	<input type="checkbox"/>	<input type="checkbox"/>	<input type="checkbox"/>	<input type="checkbox"/>	<input type="checkbox"/>	<input type="checkbox"/>	<input type="checkbox"/>	<input type="checkbox"/>	<input type="checkbox"/>	<input type="checkbox"/>	<input type="checkbox"/>	<input type="checkbox"/>	<input type="checkbox"/>	<input type="checkbox"/>	<input type="checkbox"/>	<input type="checkbox"/>	<input type="checkbox"/>	<input type="checkbox"/>	<input type="checkbox"/>	<input type="checkbox"/>	<input type="checkbox"/>
1-2 SWITCH (MT)		<input type="checkbox"/>	<input type="checkbox"/>	<input type="checkbox"/>	<input type="checkbox"/>	<input type="checkbox"/>	<input type="checkbox"/>	<input type="checkbox"/>	<input type="checkbox"/>	<input type="checkbox"/>	<input type="checkbox"/>	<input type="checkbox"/>	<input type="checkbox"/>	<input type="checkbox"/>	<input type="checkbox"/>	<input type="checkbox"/>	<input type="checkbox"/>	<input type="checkbox"/>	<input type="checkbox"/>	<input type="checkbox"/>	<input type="checkbox"/>	<input type="checkbox"/>	<input type="checkbox"/>	<input type="checkbox"/>	<input type="checkbox"/>	<input type="checkbox"/>
EGR SWITCH (Calif)		<input type="checkbox"/>	<input type="checkbox"/>	<input type="checkbox"/>	<input type="checkbox"/>	<input type="checkbox"/>	<input type="checkbox"/>	<input type="checkbox"/>	<input type="checkbox"/>	<input type="checkbox"/>	<input type="checkbox"/>	<input type="checkbox"/>	<input type="checkbox"/>	<input type="checkbox"/>	<input type="checkbox"/>	<input type="checkbox"/>	<input type="checkbox"/>	<input type="checkbox"/>	<input type="checkbox"/>	<input type="checkbox"/>	<input type="checkbox"/>	<input type="checkbox"/>	<input type="checkbox"/>	<input type="checkbox"/>	<input type="checkbox"/>	<input type="checkbox"/>
MILEAGE SWITCH		<input type="checkbox"/>	<input type="checkbox"/>	<input type="checkbox"/>	<input type="checkbox"/>	<input type="checkbox"/>	<input type="checkbox"/>	<input type="checkbox"/>	<input type="checkbox"/>	<input type="checkbox"/>	<input type="checkbox"/>	<input type="checkbox"/>	<input type="checkbox"/>	<input type="checkbox"/>	<input type="checkbox"/>	<input type="checkbox"/>	<input type="checkbox"/>	<input type="checkbox"/>	<input type="checkbox"/>	<input type="checkbox"/>	<input type="checkbox"/>	<input type="checkbox"/>	<input type="checkbox"/>	<input type="checkbox"/>	<input type="checkbox"/>	<input type="checkbox"/>
HEAT HAZARD SENSOR		<input type="checkbox"/>	<input type="checkbox"/>	<input type="checkbox"/>	<input type="checkbox"/>	<input type="checkbox"/>	<input type="checkbox"/>	<input type="checkbox"/>	<input type="checkbox"/>	<input type="checkbox"/>	<input type="checkbox"/>	<input type="checkbox"/>	<input type="checkbox"/>	<input type="checkbox"/>	<input type="checkbox"/>	<input type="checkbox"/>	<input type="checkbox"/>	<input type="checkbox"/>	<input type="checkbox"/>	<input type="checkbox"/>	<input type="checkbox"/>	<input type="checkbox"/>	<input type="checkbox"/>	<input type="checkbox"/>	<input type="checkbox"/>	<input type="checkbox"/>
SOLENOID VALVE	SHIFT A	<input type="checkbox"/>	<input type="checkbox"/>	<input type="checkbox"/>	<input type="checkbox"/>	<input type="checkbox"/>	<input type="checkbox"/>	<input type="checkbox"/>	<input type="checkbox"/>	<input type="checkbox"/>	<input type="checkbox"/>	<input type="checkbox"/>	<input type="checkbox"/>	<input type="checkbox"/>	<input type="checkbox"/>	<input type="checkbox"/>	<input type="checkbox"/>	<input type="checkbox"/>	<input type="checkbox"/>	<input type="checkbox"/>	<input type="checkbox"/>	<input type="checkbox"/>	<input type="checkbox"/>	<input type="checkbox"/>	<input type="checkbox"/>	<input type="checkbox"/>
	SHIFT B	<input type="checkbox"/>	<input type="checkbox"/>	<input type="checkbox"/>	<input type="checkbox"/>	<input type="checkbox"/>	<input type="checkbox"/>	<input type="checkbox"/>	<input type="checkbox"/>	<input type="checkbox"/>	<input type="checkbox"/>	<input type="checkbox"/>	<input type="checkbox"/>	<input type="checkbox"/>	<input type="checkbox"/>	<input type="checkbox"/>	<input type="checkbox"/>	<input type="checkbox"/>	<input type="checkbox"/>	<input type="checkbox"/>	<input type="checkbox"/>	<input type="checkbox"/>	<input type="checkbox"/>	<input type="checkbox"/>	<input type="checkbox"/>	<input type="checkbox"/>
REDUCE TORQUE SIGNAL (AT)		<input type="checkbox"/>	<input type="checkbox"/>	<input type="checkbox"/>	<input type="checkbox"/>	<input type="checkbox"/>	<input type="checkbox"/>	<input type="checkbox"/>	<input type="checkbox"/>	<input type="checkbox"/>	<input type="checkbox"/>	<input type="checkbox"/>	<input type="checkbox"/>	<input type="checkbox"/>	<input type="checkbox"/>	<input type="checkbox"/>	<input type="checkbox"/>	<input type="checkbox"/>	<input type="checkbox"/>	<input type="checkbox"/>	<input type="checkbox"/>	<input type="checkbox"/>	<input type="checkbox"/>	<input type="checkbox"/>	<input type="checkbox"/>	<input type="checkbox"/>
SLIP LOCK-UP SIGNAL (AT)		<input type="checkbox"/>	<input type="checkbox"/>	<input type="checkbox"/>	<input type="checkbox"/>	<input type="checkbox"/>	<input type="checkbox"/>	<input type="checkbox"/>	<input type="checkbox"/>	<input type="checkbox"/>	<input type="checkbox"/>	<input type="checkbox"/>	<input type="checkbox"/>	<input type="checkbox"/>	<input type="checkbox"/>	<input type="checkbox"/>	<input type="checkbox"/>	<input type="checkbox"/>	<input type="checkbox"/>	<input type="checkbox"/>	<input type="checkbox"/>	<input type="checkbox"/>	<input type="checkbox"/>	<input type="checkbox"/>	<input type="checkbox"/>	<input type="checkbox"/>
INHIBITOR SIGNAL (AT)		<input type="checkbox"/>	<input type="checkbox"/>	<input type="checkbox"/>	<input type="checkbox"/>	<input type="checkbox"/>	<input type="checkbox"/>	<input type="checkbox"/>	<input type="checkbox"/>	<input type="checkbox"/>	<input type="checkbox"/>	<input type="checkbox"/>	<input type="checkbox"/>	<input type="checkbox"/>	<input type="checkbox"/>	<input type="checkbox"/>	<input type="checkbox"/>	<input type="checkbox"/>	<input type="checkbox"/>	<input type="checkbox"/>	<input type="checkbox"/>	<input type="checkbox"/>	<input type="checkbox"/>	<input type="checkbox"/>	<input type="checkbox"/>	<input type="checkbox"/>
DIAGNOSIS CONNECTOR (TEN-TERMINAL)		<input type="checkbox"/>	<input type="checkbox"/>	<input type="checkbox"/>	<input type="checkbox"/>	<input type="checkbox"/>	<input type="checkbox"/>	<input type="checkbox"/>	<input type="checkbox"/>	<input type="checkbox"/>	<input type="checkbox"/>	<input type="checkbox"/>	<input type="checkbox"/>	<input type="checkbox"/>	<input type="checkbox"/>	<input type="checkbox"/>	<input type="checkbox"/>	<input type="checkbox"/>	<input type="checkbox"/>	<input type="checkbox"/>	<input type="checkbox"/>	<input type="checkbox"/>	<input type="checkbox"/>	<input type="checkbox"/>	<input type="checkbox"/>	<input type="checkbox"/>
ATMOSPHERIC PRESSURE SENSOR (IN ECU)		<input type="checkbox"/>	<input type="checkbox"/>	<input type="checkbox"/>	<input type="checkbox"/>	<input type="checkbox"/>	<input type="checkbox"/>	<input type="checkbox"/>	<input type="checkbox"/>	<input type="checkbox"/>	<input type="checkbox"/>	<input type="checkbox"/>	<input type="checkbox"/>	<input type="checkbox"/>	<input type="checkbox"/>	<input type="checkbox"/>	<input type="checkbox"/>	<input type="checkbox"/>	<input type="checkbox"/>	<input type="checkbox"/>	<input type="checkbox"/>	<input type="checkbox"/>	<input type="checkbox"/>	<input type="checkbox"/>	<input type="checkbox"/>	<input type="checkbox"/>

TROUBLESHOOTING GUIDE

F

Output devices and Engine condition

ENGINE CONDITION		CRANKING (COLD ENGINE)	WARMING UP (DURING IDLE)	MEDIUM LOAD		ACCELERATION	HEAVY LOAD	DECELERATION	IDLE	IG: ON (ENGINE NOT RUNNING)	REMARK	
				COLD	WARM							
OUTPUT DEVICE												
INJECTOR	FUEL INJECTION AMOUNT	Rich		Normal		Rich		FUEL CUT*	Rich	No Injection		
	Primary	Operate						Not operate	Operate			
	Secondary	Not operate				Operate		Not operate				
CIRCUIT OPENING RELAY		ON									OFF	
FUEL PUMP RELAY		OFF (Low speed)				ON (High speed)		OFF (Low speed)				
IGNITER		Fixed at BTDC 5°	Advanced: depends on engine condition						Fixed at ATDC 5° (L) ATDC 20° (T)			
ACCELERATED WARM-UP (AWS)		ON		OFF								
IDLE SPEED CONTROL (ISC)		ON (Feedback duty)		ON (Fixed duty)				ON (Feedback duty)				
DOUBLE THROTTLE CONTROL		ON (Closed)		OFF (Open)	ON (AT only)	OFF (Open)						
TURBO PRE-CONTROL		OFF (Closed)		Depends on engine condition				OFF (Closed)				
WASTEGATE CONTROL		OFF (Closed)			Depends on engine condition			OFF (Closed)				
TURBO CONTROL		OFF (Closed)			ON (Open)			OFF (Closed)				
CHARGE CONTROL		ON (Closed)			OFF (Open)			ON (Closed)				
CHARGE RELIEF CONTROL		OFF (Open)			ON (closed)			OFF (Closed)				
RELIEF 1		OFF (Closed)		ON (Open)		OFF (Closed)						
SWITCHING		OFF (Port)		ON (Split)			OFF (Port)					
SPLIT AIR BYPASS		OFF (Closed)		ON (Open)			OFF (Closed)					
PORT AIR BYPASS		OFF (Closed)		ON (Open)		OFF (Closed)						
RELIEF 2		ON (Open)		OFF (Closed)								
PRESSURE REGULATOR CONTROL (PRC)		OFF (Vacuum to pressure regulator)							ON*	OFF	* During hot start only	
PURGE CONTROL (PURGE)		OFF		ON (Purge)		OFF						
EXHAUST GAS RECIRCULATION (EGR)		OFF (EGR Cut)		ON* (EGR)		OFF (EGR Cut)					Engine speed: 1,700-3,850 rpm	
A/C RELAY		OFF (A/C cut)	ON			OFF (A/C cut)	ON					
COOLING FAN RELAY		OFF		Depends on engine coolant temperature								
METERING OIL PUMP (MOP)		OFF		ON						OFF		

F

TROUBLESHOOTING GUIDE

USING THIS SECTION

Introduction

Most of the fuel and emission control systems are electronically controlled, often making it difficult to diagnose problems, especially intermittent problems. Before undertaking actual checks, take a few minutes to talk with a customer who approaches with a drivability complaint. The customer is often a good source of information on such problems, especially the intermittent ones. Through a talk with the customer, you will usually find out what the symptoms are and under what conditions they occur.

Work flow

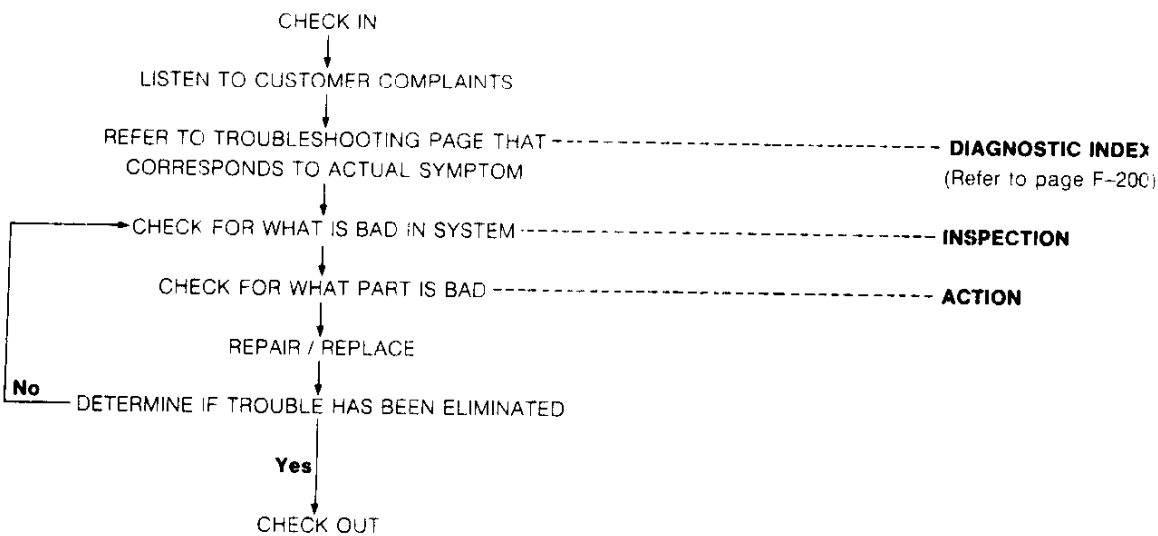

16E0F2 254

Diagnostic index

DESCRIPTION:
Describes each troubleshooting item

PAGE:
Shows the reference page or section.

No.:
Each troubleshooting item is assigned a number.

TROUBLESHOOTING ITEM:
There are 58 troubleshooting items. Choose the item that most closely corresponds to the actual symptom.

F TROUBLESHOOTING GUIDE			
DIAGNOSTIC INDEX			
No.	TROUBLESHOOTING ITEM	DESCRIPTION	PAGE
1	Melts main of other tune		F-204
2	Will not crank or cranks slowly	Starter does not work Starter cranks engine at slow speed	Section G
3	Cranks normally but will not start	No combustion Starter cranks engine at normal speed but engine shows no indication of firing	F-205
4		Partial combustion - when engine cold Starter cranks engine at normal speed and engine shows indication of firing but will not run when engine is cold or at initial starting	F-205
5		Partial combustion - when warm-up Starter cranks engine at normal speed and engine shows indication of firing but will not run when engine is warm	F-207
6	Will start in other than P and N ranges	Engine starts in P, N and other ranges	Section K
7	Cranks normally but hard to start	Any engine temp. Starter cranks engine at normal speed but engine requires excessive cranking time before starting at any engine temperature Engine starts after stalling a few times at any engine temperature	
		When engine cold Starter cranks engine at normal speed but engine requires excessive cranking time before starting when engine is cold Engine starts after stalling a few times when engine is cold	F-205
		After Starter cranks engine at normal speed but engine requires excessive cranking time before starting after warm-up Engine starts after stalling a few times at any engine temp.	
18	Engine stalls		
19			

Troubleshooting chart

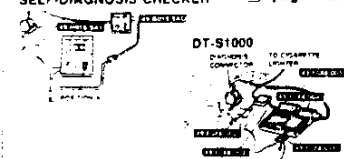
7, 8, 9	CRANKS NORMALLY BUT HARD TO START	<ul style="list-style-type: none"> • ANY ENGINE TEMPERATURE • WHEN ENGINE COLD • AFTER WARM-UP 		
DESCRIPTION	<ul style="list-style-type: none"> • Starter cranks engine at normal speed but engine requires excessive cranking time before starting • Engine starts after stalling a few times • Battery in normal condition • Engine runs normally at idle (if idle condition not OK, refer to "Engine rough" (Nos. 19, 20, 21, 22, or 23)) 			
(TROUBLESHOOTING HINTS)	<table style="width: 100%; border: none;"> <tr> <td style="width: 50%; border: none; vertical-align: top;"> <ul style="list-style-type: none"> ① Injector <ul style="list-style-type: none"> • Fuel leakage from injector(s) ② Fuel pump <ul style="list-style-type: none"> • Poor connection of pump connector • Poor connection of circuit opening relay connector ③ Pressure regulator <ul style="list-style-type: none"> • Malfunction of pressure regulator ④ Fast idle cam <ul style="list-style-type: none"> • Malfunction of fast idle cam (when engine cold) ⑤ Spark plug <ul style="list-style-type: none"> • Dirty or worn spark plug(s) </td> <td style="width: 50%; border: none; vertical-align: top;"> <ul style="list-style-type: none"> ⑥ Intake air system <ul style="list-style-type: none"> • Air leakage ⑦ Water thermostator <ul style="list-style-type: none"> • Poor connection of water thermostator • Malfunction of water thermostator ⑧ Solenoid valve (Purge control) <ul style="list-style-type: none"> • Air leakage ⑨ Metering oil pump <ul style="list-style-type: none"> • Malfunction of pump ⑩ Crank angle sensor <ul style="list-style-type: none"> • Ground circuit open </td> </tr> </table>		<ul style="list-style-type: none"> ① Injector <ul style="list-style-type: none"> • Fuel leakage from injector(s) ② Fuel pump <ul style="list-style-type: none"> • Poor connection of pump connector • Poor connection of circuit opening relay connector ③ Pressure regulator <ul style="list-style-type: none"> • Malfunction of pressure regulator ④ Fast idle cam <ul style="list-style-type: none"> • Malfunction of fast idle cam (when engine cold) ⑤ Spark plug <ul style="list-style-type: none"> • Dirty or worn spark plug(s) 	<ul style="list-style-type: none"> ⑥ Intake air system <ul style="list-style-type: none"> • Air leakage ⑦ Water thermostator <ul style="list-style-type: none"> • Poor connection of water thermostator • Malfunction of water thermostator ⑧ Solenoid valve (Purge control) <ul style="list-style-type: none"> • Air leakage ⑨ Metering oil pump <ul style="list-style-type: none"> • Malfunction of pump ⑩ Crank angle sensor <ul style="list-style-type: none"> • Ground circuit open
<ul style="list-style-type: none"> ① Injector <ul style="list-style-type: none"> • Fuel leakage from injector(s) ② Fuel pump <ul style="list-style-type: none"> • Poor connection of pump connector • Poor connection of circuit opening relay connector ③ Pressure regulator <ul style="list-style-type: none"> • Malfunction of pressure regulator ④ Fast idle cam <ul style="list-style-type: none"> • Malfunction of fast idle cam (when engine cold) ⑤ Spark plug <ul style="list-style-type: none"> • Dirty or worn spark plug(s) 	<ul style="list-style-type: none"> ⑥ Intake air system <ul style="list-style-type: none"> • Air leakage ⑦ Water thermostator <ul style="list-style-type: none"> • Poor connection of water thermostator • Malfunction of water thermostator ⑧ Solenoid valve (Purge control) <ul style="list-style-type: none"> • Air leakage ⑨ Metering oil pump <ul style="list-style-type: none"> • Malfunction of pump ⑩ Crank angle sensor <ul style="list-style-type: none"> • Ground circuit open 			
STEP	INSPECTION	ACTION		
1	Is "00" or "No service codes" displayed on SST with ignition switch ON? SELF-DIAGNOSIS CHECKER → page F-20 	Yes: "00" or "No service codes" displayed Go to next step No: Service Code No. displayed Check for cause (Refer to specified check sequence)		
2	Is air leakage felt or heard at intake air system components at idle?	Yes: Repair or replace		

16E0F-255

DESCRIPTION:

Further describes the system. Confirm that the chart addresses the actual symptom before beginning troubleshooting.

TROUBLESHOOTING HINTS:

This describes the possible point of malfunction.

STEP:

This Shows the order of troubleshooting. Proceed with troubleshooting as indicated.

INSPECTION:

This describes an inspection to quickly determine the malfunction of parts. If a detailed procedure is necessary to perform the INSPECTION, refer to the page specified by the "→" mark.

ACTION:

This recommends the appropriate action to take as a result (Yes/No) of the INSPECTION. How to perform the actions is described on the reference page specified by the "→" mark.

16E0F-256

F

TROUBLESHOOTING GUIDE

DIAGNOSTIC INDEX

TROUBLESHOOTING ITEM		DESCRIPTION	PAGE
No.	TROUBLE		
1	Melts main or other fuse	-	F-204
2	Will not crank or cranks slowly	Starter does not work Starter cranks engine at slow speed	Section G
3	Crank normally but will not start	No combustion	F-205
4		Partial combustion - when engine cold	F-205
5		Partial combustion - when warm-up	F-207
6	Will start in other than P and N ranges	Engine starts in P, N and other ranges	Section K
7	Crank normally but hard to start	Any engine temperature	F-208
8		When engine cold	
9		After warm-up	
10	Engine stalls	Idle at any engine temperature	F-210
11		During fast idle	
12		Idle after warm-up	
13		Idle with A/C, P/S, and/or E/L ON	F-212
*14		Idle when shifted from N or P to other ranges	Section K
15		Driveaway	F-213
16		On acceleration	F-215
17		While cruising	
*18	On deceleration	F-216 Section K	
19	Engine rough	Idle at any engine temperature	F-217
20		During fast idle	
21		Idle after warm-up	

* Refer to Section F2 before referring to Section K.

TROUBLESHOOTING GUIDE

F

TROUBLESHOOTING ITEM		DESCRIPTION	PAGE
No.	TROUBLE		
22	Engine rough	Idle with A/C, P/S, and/or E/L ON	F-219
23		Idle when shifted from N or P to other range	
24*		Or deceleration	F-220 Section K
25*	Poor acceleration	Driveaway	F-22 Section K
26*		Or acceleration	
27	High idle speed after warm-up	Idle speed continues at fast idle after warm-up Engine returns slowly to idle after accelerator is released	F-223
28	Idle fluctuates / Idle hunts	Engine speed hunts between specified idle speed and higher speed	F-225
29	Hesitates / Stumbles on acceleration	Momentary pause at beginning of acceleration or during acceleration	F-226
30*	Surges while cruising	Momentary minor irregularity in engine power at steady vehicle speed	F-228 Section K
31*	Lack of power	Performance poor under load (i.e., power down when climbing hills)	F-229 Section K
32*	Poor fuel economy	Fuel economy unsatisfactory	F-229 Section K
33	A/C does not work	A/C compressor magnetic clutch does not engage when A/C switch ON	F-229
34	Knocking / Pinging	Sound produced as air/fuel mixture is ignited by something other than spark plug (i.e., hot spot in combustion chamber)	F-230
35	Fuel odor	Gasoline fuel smell or visible leaks	F-230
36	Exhaust sulfur smell	Rotten egg (sulfur) smell from exhaust	F-230
37	High oil consumption	Oil consumption excessive	F-230
38	Self-Diagnosis Checker flashes 88 / DT-S1000 indicates "SYSTEM ERROR"	Checker flashes 88 with test connector grounded or DT-S1000 indicates "System error"	F-231
39	MIL never ON	Self-Diagnosis Checker or DT-S1000 indicates Service Code No. of input device but MIL never ON	F-231
40	Vehicle does not move in D, S, L and/or R ranges	No creep at all Vehicle does not move when accelerator pedal is depressed after shifted to D, S, L and/or R ranges	Section K
41	Vehicle moves in N range	Vehicle creeps in N ranges Vehicle moves with accelerator pedal not depressed	Section K
42	Vehicle moves in P range	Vehicle rolls in P range	Section K
43	Excessive creep	Vehicle moves quickly in D, S, L and R range (with accelerator pedal not depressed) Note • Excessive N to R range and N to D range shift shock felt	Section K

* Refer to Section F before referring to K Sections

F

TROUBLESHOOTING GUIDE

TROUBLESHOOTING ITEM		DESCRIPTION	PAGE	
No.	TROUBLE			
44	No shift	Single range shift (1st → 2nd, 2nd → 3rd or 3rd → O/D) only Sometimes shifts correctly Note ● Gear position held in hold mode.	Section K	
45	Abnormal shift	Shifts incorrectly (incorrect shift pattern) (ex) Vehicle shifts 1st → O/D directly when accelerating with accelerator pedal depressed slightly	Section K	
46	Frequent shifting	Downshift occurs when accelerated slightly in D, S and L ranges (except hold mode)	Section K	
47	Shift point high or low	Shift points do not match shift diagram Shift delayed when accelerating Shift occur too fast when accelerating and engine speed does not increase	Section K	
48	No lockup	No lockup when vehicle speed reaches lockup range	Section K	
49	No kickdown	Does not downshift when accelerator pedal depressed more than 7/8 within kickdown range	Section K	
50	Engine speed flares up	When accelerating	Engine speed flares up on acceleration	Section K
51		When upshifting and/or downshifting	Engine flares up when accelerator pedal depressed before upshifting Engine flares up suddenly when accelerator pedal depressed before downshifting	Section K
52	Excessive shift shock	P, N to R and/or N to D	Strong shift shock felt at idle when shifting from N to D or R range	Section K
53		When upshifting and/or downshifting	Excessive shift shock felt when accelerating at upshifting Excessive shift shock felt when accelerator pedal depressed at downshifting during cruising	Section K
54	No engine braking	Engine speed drops to idle but vehicle does not slow when accelerator pedal released during cruising at medium to high speed Engine speed drops to idle but vehicle does not slow when accelerator pedal released when in L range at low vehicle speed	Section K	
55	No mode change	Mode does not change to/from normal mode in D range Hold mode not engaged or not cancelled	Section K	
56	Transmission noise	All ranges	Transmission noisy in all ranges when vehicle is idling	Section K
57		D, S, L, R ranges	Abnormal noise from transmission in D, S, L, R	Section K
58	Transmission overheats	ATF smells burnt and/or is discolored	Section K	

16E0F2-257

Description of Drivability Problems

- STUMBLE : Mild jerking during acceleration.
- HESITATION : Flat spot occurring just after the accelerator pedal is depressed.
- SURGE : Continuous soft jerking while cruising.

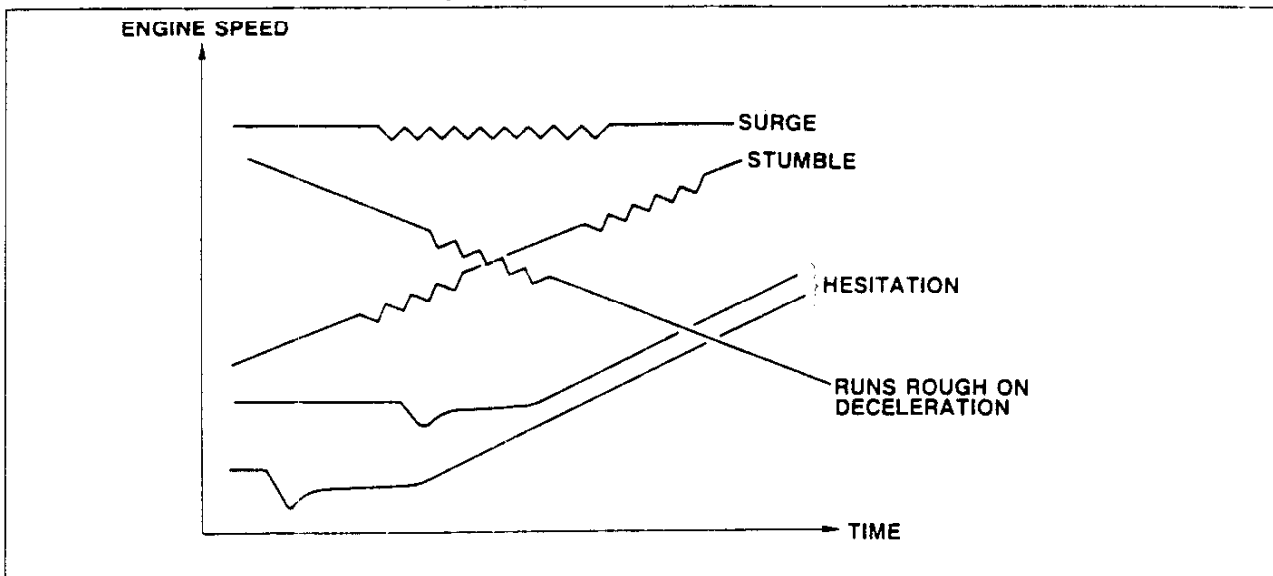

16E0F2-258

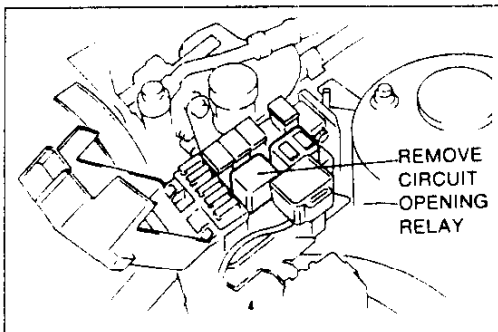

16E0F2-259

PRECAUTION

Fuel Pressure Release and Servicing Fuel System

- a) Fuel in the fuel system remains under high pressure when the engine is not running. Before disconnecting any fuel line, release the fuel pressure from the fuel system as described to reduce the possibility of injury or fire.
 1. Start the engine.
 2. Remove the circuit opening relay.
 3. After the engine stalls, turn OFF the ignition switch.
 4. Install the circuit opening relay.

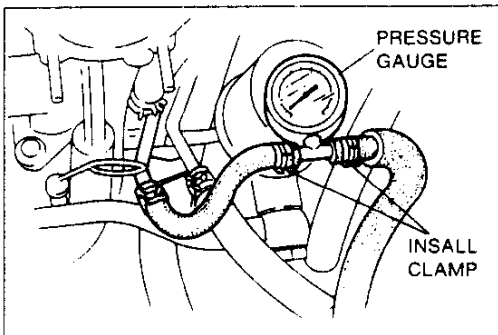

16E0F2-259

- b) Use a rag as protection from fuel spray when disconnecting the hoses. Plug the hoses after removal.
- c) When inspecting the fuel system, use a suitable fuel pressure gauge.

Caution

- Install hose clamps to secure the fuel pressure gauge to prevent fuel leakage.

SYMPTOM TROUBLESHOOTING

1 **MELTS MAIN OR OTHER FUSE**

[TROUBLESHOOTING HINTS]

Check the condition of the fuse

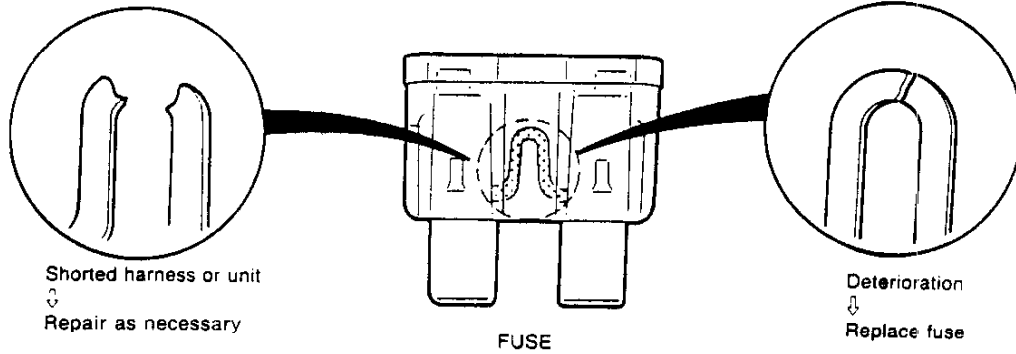

Damaged Fuse	Related Wiring Harness	
MAIN (120A)	Main fuse	Alternator (B)
BTN (60A)	BTN fuse	ROOM fuse (W/R)
ROOM (10A)	ROOM fuse	ECU terminal 1A (L/R)
EGI INJ (30A)	Main relay	<ul style="list-style-type: none"> Injectors (B/Y) ECU terminal 1B (B/W) Oxygen sensor (B/W) Solenoid valves (B/W) E/L unit (B/W) Air pump relay (B/W)
ENGINE (15A)	ENGINE fuse	Main relay (B/W)
METER (15A)	METER fuse	Diagnosis connector terminal + B (B/Y)
FUEL PUMP (20A)	FUEL PUMP fuse Circuit opening relay	Circuit opening relay (L) Fuel pump (W/R)

TROUBLESHOOTING GUIDE

F

3	CRANK NORMALLY BUT WILL NOT START	● NO COMBUSTION
DESCRIPTION	● Starter cranks engine at normal speed but engine shows no indication of firing	
[TROUBLESHOOTING HINTS]		
<ul style="list-style-type: none"> ① Crank angle sensor <ul style="list-style-type: none"> ● Poor connection of connector ② Main relay <ul style="list-style-type: none"> ● Poor connection of connector ● Malfunction of relay ③ Fuel pump <ul style="list-style-type: none"> ● No fuel in tank ● Poor connection of fuel pump connector ④ ECU <ul style="list-style-type: none"> ● Poor connection of connector (Especially 1H, 1O, 1T, 3I, 4D, 4E, 4G, 4H) ⑤ Igniter <ul style="list-style-type: none"> ● Poor connection of connector ⑥ Injector <ul style="list-style-type: none"> ● Poor connection of connector 		

4	CRANKS NORMALLY BUT WILL NOT START	● PARTIAL COMBUSTION – WHEN ENGINE COLD
DESCRIPTION	<ul style="list-style-type: none"> ● Starter cranks engine at normal speed and engine shows indication of firing but will not run when engine is cold at initial starting ● Engine will not continue running when cold when ignition switch is returned from STA to IG position ● Refer to "ENGINE STALLS" if this symptom initially appears after engine stalls ● Fuel in tank ● Battery in normal condition 	
[TROUBLESHOOTING HINTS]		
<ul style="list-style-type: none"> <li style="width: 50%;">① Igniter <ul style="list-style-type: none"> ● Poor connection of connector <li style="width: 50%;">⑥ Water thermosensor <ul style="list-style-type: none"> ● Poor connection of connector <li style="width: 50%;">② Ignition coil <ul style="list-style-type: none"> ● Poor connection of connector <li style="width: 50%;">⑦ Engine compression <li style="width: 50%;">③ Spark plug <ul style="list-style-type: none"> ● Dirty or worn spark plug(s) <li style="width: 50%;">⑧ ECU <ul style="list-style-type: none"> ● Poor connection of connector (Especially 1B, 1G, 1H, 1J, 1N, 1O, 1T, 3E, 4E, 4G, 4H) <li style="width: 50%;">④ Injector (primary) <ul style="list-style-type: none"> ● Poor connection of connector ● Fuel leakage from injector(s) <li style="width: 50%;">⑨ Solenoid valve (Purge control) <ul style="list-style-type: none"> ● Short circuit (Solenoid valve fully opened) <li style="width: 50%;">⑤ Intake air system <ul style="list-style-type: none"> ● Air leakage 		

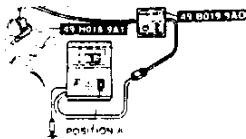
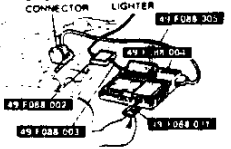
STEP	INSPECTION		ACTION
1	Is "00" or "No service codes" displayed on SST with ignition switch ON? <div style="text-align: right; margin-right: 20px;">☞ page F-20</div> <div style="display: flex; justify-content: space-around;"> <div style="text-align: center;"> SELF-DIAGNOSIS CHECKER  </div> <div style="text-align: center;"> DT-S1000 DIAGNOSIS CONNECTOR TO CIGARETTE LIGHTER  </div> </div>	Yes	"00" or "No service codes" displayed Go to next step
		No	Service Code No. displayed Check for cause (Refer to specified check sequence)

F

TROUBLESHOOTING GUIDE

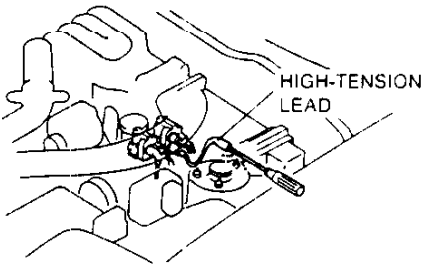
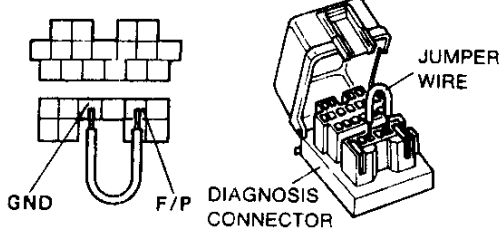
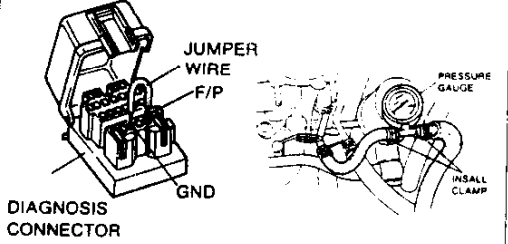
STEP	INSPECTION		ACTION
2	<p>Is strong blue spark visible at each disconnected high-tension lead while cranking engine?</p> 	<p>Yes</p>	<p>Go to next step</p>
		<p>No</p>	<p>Check ignition system ➤ Section G</p>
3	<p>Are spark plugs OK?</p> <p style="text-align: right;">➤ Section G</p>	<p>Yes</p>	<p>Go to next step</p>
		<p>No</p>	<p>Clean or replace</p>
4	<p>Connect jumper wire between F/P and GND terminals of diagnosis connector; will engine start?</p> 	<p>Yes</p>	<p>Check as follows:</p> <ul style="list-style-type: none"> ● 1T terminal voltage at ECU ➤ page F-156 ● Continuity between 1T terminal and circuit opening relay connector terminal ● Condition of ECU and circuit opening relay connector female terminals
		<p>No</p>	<p>Check if fuel pump operating sound is heard</p> <ul style="list-style-type: none"> ● If yes, go to next step ● If no, check fuel pump and wiring harness ➤ page F-100
5	<p>Are ECU terminal voltages OK?</p> <p style="text-align: right;">➤ page F-152</p>	<p>Yes</p>	<p>Go to next step</p>
		<p>No</p>	<p>Check for cause ➤ page F-153</p>
6	<p>Connect diagnosis connector terminals F/P and GND with a jumper wire; is fuel line pressure correct with ignition switch ON?</p> <p style="text-align: right;">➤ page F-98</p> <p>Fuel line pressure: 250-260 kPa { 2.5-2.7 kgf/cm², 36-38 psi }</p> 	<p>Yes</p>	<p>Go to next step</p>
		<p>No</p>	<p>Low pressure</p> <p>Check fuel line pressure while pinching fuel return hose</p> <ul style="list-style-type: none"> ● If pressure quickly increases, check pressure regulator ➤ page F-104 ● If pressure gradually increases, check for clogging between fuel pump and pressure regulator <p>If hose not clogged, check fuel pump maximum pressure ➤ page F-101</p>

TROUBLESHOOTING GUIDE

STEP	INSPECTION		ACTION
7	Are injectors OK? ☞ page F-107 <ul style="list-style-type: none"> ● Fuel leakage ● Primary injector(s) clogged 	Yes	Go to next step
		No	Replace injector(s) ☞ page F-105
8	Is engine compression OK? ☞ Section C <p>Compression 690 kPa {7.0 kgf/cm², 100 psi} – 250 rpm Differential limit of chambers 150 kPa {1.5 kgf/cm², 21psi} – 250 rpm</p>	Yes	Go to next step
		No	Check for cause ☞ Section C
9	Try known good ECU; does condition improve? ☞ page F-150		

5	CRANKS NORMALLY BUT WILL NOT START	● PARTIAL COMBUSTION – AFTER WARM UP
DESCRIP- TION	<ul style="list-style-type: none"> ● Starter cranks engine at normal speed and engine shows indication of firing but will not run when engine is warm ● Engine will not continue running when ignition switch is returned from STA to IG position 	
[TROUBLESHOOTING HINTS]		
① Solenoid valve (PRC) <ul style="list-style-type: none"> ● Poor connection of solenoid valve connector or ECU 4M terminal 	④ Evaporative emission control <ul style="list-style-type: none"> ● Malfunction of check valve (two-way) 	⑤ Fuel pump <ul style="list-style-type: none"> ● Malfunction of circuit opening relay
② Fuel <ul style="list-style-type: none"> ● High RVP (winter) fuel used in warm weather 		
③ Water thermosensor <ul style="list-style-type: none"> ● Malfunction of water thermosensor 		

F

TROUBLESHOOTING GUIDE

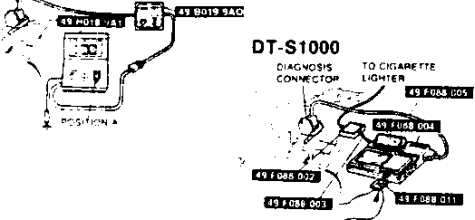
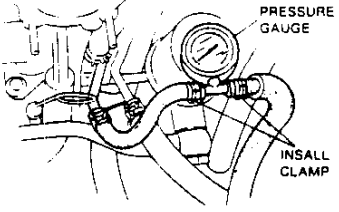
7, 8, 9	CRANKS NORMALLY BUT HARD TO START	<ul style="list-style-type: none"> ● ANY ENGINE TEMPERATURE ● WHEN ENGINE COLD ● AFTER WARM-UP 						
DESCRIPTION	<ul style="list-style-type: none"> ● Starter cranks engine at normal speed but engine requires excessive cranking time before starting ● Engine starts after stalling a few times ● Battery in normal condition ● Engine runs normally at idle (if idle condition not OK, refer to "Engine rough" [Nos. 19, 20, 21, 22, or 23]) 							
[TROUBLESHOOTING HINTS]								
<table border="0" style="width: 100%;"> <tr> <td style="width: 50%; vertical-align: top;"> <ul style="list-style-type: none"> ① Injector <ul style="list-style-type: none"> ● Fuel leakage from injector(s) ② Fuel pump <ul style="list-style-type: none"> ● Poor connection of pump connector ● Poor connection of circuit opening relay connector ③ Pressure regulator <ul style="list-style-type: none"> ● Malfunction of pressure regulator ④ Fast idle cam <ul style="list-style-type: none"> ● Malfunction of fast idle cam (when engine cold) ⑤ Spark plug <ul style="list-style-type: none"> ● Dirty or worn spark plug(s) </td> <td style="width: 50%; vertical-align: top;"> <ul style="list-style-type: none"> ⑥ Intake air system <ul style="list-style-type: none"> ● Air leakage ⑦ Water thermostator <ul style="list-style-type: none"> ● Poor connection of water thrmosensor ● Malfunction of water thermostator ⑧ Solenoid valve (Purge control) <ul style="list-style-type: none"> ● Air leakage ⑨ Metering oil pump <ul style="list-style-type: none"> ● Malfunction of pump ⑩ Crank angle sensor <ul style="list-style-type: none"> ● Ground circuit open </td> </tr> </table>			<ul style="list-style-type: none"> ① Injector <ul style="list-style-type: none"> ● Fuel leakage from injector(s) ② Fuel pump <ul style="list-style-type: none"> ● Poor connection of pump connector ● Poor connection of circuit opening relay connector ③ Pressure regulator <ul style="list-style-type: none"> ● Malfunction of pressure regulator ④ Fast idle cam <ul style="list-style-type: none"> ● Malfunction of fast idle cam (when engine cold) ⑤ Spark plug <ul style="list-style-type: none"> ● Dirty or worn spark plug(s) 	<ul style="list-style-type: none"> ⑥ Intake air system <ul style="list-style-type: none"> ● Air leakage ⑦ Water thermostator <ul style="list-style-type: none"> ● Poor connection of water thrmosensor ● Malfunction of water thermostator ⑧ Solenoid valve (Purge control) <ul style="list-style-type: none"> ● Air leakage ⑨ Metering oil pump <ul style="list-style-type: none"> ● Malfunction of pump ⑩ Crank angle sensor <ul style="list-style-type: none"> ● Ground circuit open 				
<ul style="list-style-type: none"> ① Injector <ul style="list-style-type: none"> ● Fuel leakage from injector(s) ② Fuel pump <ul style="list-style-type: none"> ● Poor connection of pump connector ● Poor connection of circuit opening relay connector ③ Pressure regulator <ul style="list-style-type: none"> ● Malfunction of pressure regulator ④ Fast idle cam <ul style="list-style-type: none"> ● Malfunction of fast idle cam (when engine cold) ⑤ Spark plug <ul style="list-style-type: none"> ● Dirty or worn spark plug(s) 	<ul style="list-style-type: none"> ⑥ Intake air system <ul style="list-style-type: none"> ● Air leakage ⑦ Water thermostator <ul style="list-style-type: none"> ● Poor connection of water thrmosensor ● Malfunction of water thermostator ⑧ Solenoid valve (Purge control) <ul style="list-style-type: none"> ● Air leakage ⑨ Metering oil pump <ul style="list-style-type: none"> ● Malfunction of pump ⑩ Crank angle sensor <ul style="list-style-type: none"> ● Ground circuit open 							
STEP	INSPECTION	ACTION						
1.	<p>Is "00" or "No service codes" displayed on SST with ignition switch ON?</p> <p>SELF-DIAGNOSIS CHECKER page F-20</p> 	<table border="0" style="width: 100%;"> <tr> <td style="width: 50px;">Yes</td> <td>"00" or "No service codes" displayed</td> </tr> <tr> <td colspan="2">Go to next step</td> </tr> <tr> <td>No</td> <td>Service Code No. displayed Check for cause (Refer to specified check sequence)</td> </tr> </table>	Yes	"00" or "No service codes" displayed	Go to next step		No	Service Code No. displayed Check for cause (Refer to specified check sequence)
Yes	"00" or "No service codes" displayed							
Go to next step								
No	Service Code No. displayed Check for cause (Refer to specified check sequence)							
2.	Is air leakage felt or heard at intake air system components at idle?	<table border="0" style="width: 100%;"> <tr> <td style="width: 50px;">Yes</td> <td>Repair or replace</td> </tr> <tr> <td>No</td> <td>Go to next step</td> </tr> </table>	Yes	Repair or replace	No	Go to next step		
Yes	Repair or replace							
No	Go to next step							
3.	Is fast idle cam OK? page F-79	<table border="0" style="width: 100%;"> <tr> <td style="width: 50px;">Yes</td> <td>Go to next step</td> </tr> <tr> <td>No</td> <td>Adjust page F-79</td> </tr> </table>	Yes	Go to next step	No	Adjust page F-79		
Yes	Go to next step							
No	Adjust page F-79							
4.	<p>Connect diagnosis connector terminals F/P and GND with a jumper wire; is fuel line pressure correct with ignition switch ON?</p> <p>Fuel line pressure: page F-98 250-260 kPa (2.5-2.7 kgf/cm², 36-38 psi)</p> 	<table border="0" style="width: 100%;"> <tr> <td style="width: 50px;">Yes</td> <td>Go to next step</td> </tr> <tr> <td>No</td> <td>Low pressure Check fuel line pressure while pinching fuel return hose <ul style="list-style-type: none"> ● If pressure quickly increases, check pressure regulator page F-104 ● If pressure gradually increases, check for clogging between fuel pump and pressure regulator If hose not clogged, check fuel pump maximum pressure page F-101 </td> </tr> </table>	Yes	Go to next step	No	Low pressure Check fuel line pressure while pinching fuel return hose <ul style="list-style-type: none"> ● If pressure quickly increases, check pressure regulator page F-104 ● If pressure gradually increases, check for clogging between fuel pump and pressure regulator If hose not clogged, check fuel pump maximum pressure page F-101		
Yes	Go to next step							
No	Low pressure Check fuel line pressure while pinching fuel return hose <ul style="list-style-type: none"> ● If pressure quickly increases, check pressure regulator page F-104 ● If pressure gradually increases, check for clogging between fuel pump and pressure regulator If hose not clogged, check fuel pump maximum pressure page F-101							

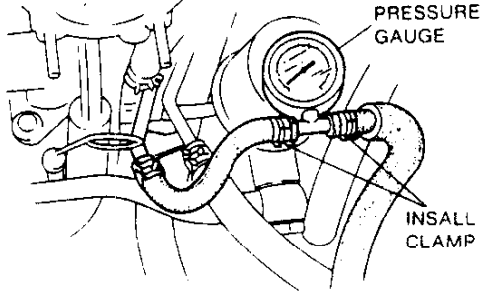
STEP	INSPECTION		ACTION
5	<p>Is fuel line pressure held after ignition switch is turned OFF?</p> <p style="text-align: right;">➤ page F-97</p> <p>Fuel pressure: More than 150 kPa (1.5 kgf/cm², 21 psi)</p> 	Yes	Go to next step
		No	<p>Plug outlet of pressure regulator, Is fuel line pressure held after ignition switch is turned OFF?</p> <p style="text-align: right;">➤ page F-100 ➤ page F-104 ➤ page F-101</p> <ul style="list-style-type: none"> ● If yes, replace pressure regulator ● If no, check fuel pump hold pressure If fuel pump OK, check injectors for fuel leakage <p style="text-align: right;">➤ page F-106</p>
6	<p>Are spark plugs OK?</p> <p style="text-align: right;">➤ Section G</p>	Yes	Go to next step
		No	Repair or replace
7	<p>Is EGR control system OK?</p> <p style="text-align: right;">➤ page F-126</p>	Yes	Go to next step
		No	<p>Check as follows:</p> <ul style="list-style-type: none"> ● Solenoid valve (EGR) for sticking ● Condition of solenoid valve connector female terminal(s)
8	<p>Try known good ECU; does condition improve?</p> <p style="text-align: right;">➤ page F-150</p>		

16E0F2-266

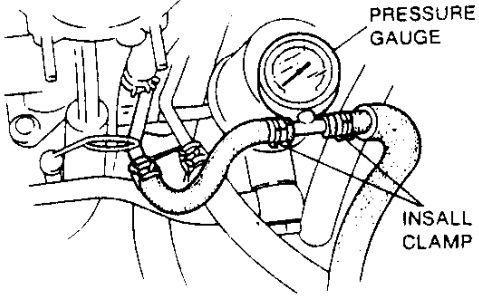
STEP	INSPECTION		ACTION
4	Are following ECU terminal voltages OK? ☞ page F-152 <ul style="list-style-type: none"> ● 1B (ECU power) ● 1G, 1H, 1J (Igniter) ● 1O (Pressure sensor) ● 1T (Circuit opening relay) ● 3E (Water thermosensor) ● 3F (Throttle sensor narrow range) ● 4E, 4G, 4H (Crank angle sensor) ● 4O (Solenoid valve (EGR)) ● 4P (Solenoid valve (AWS)) ● 4Q (Solenoid valve (ISC)) ● 4W, 4Y (Primary fuel injector) 	Yes	Go to next step
		No	Check for cause ☞ page F-153
5	Connect diagnosis connector terminals F/P and GND with a jumper wire; is fuel line pressure correct with ignition switch ON? ☞ page F-98 Fuel line pressure: 250-260 kPa {2.5-2.7 kgf/cm ² , 36-38 psi}	Yes	Go to next step
		No	Low pressure Check fuel line pressure while pinching fuel return hose <ul style="list-style-type: none"> ● If pressure quickly increases, check pressure regulator ☞ page F-104 ● If pressure gradually increases, check for clogging between fuel pump and pressure regulator If hose not clogged, check fuel pump maximum pressure ☞ page F-101
6	Is engine compression correct? ☞ Section C Compression 690 kPa {7.0 kgf/cm ² , 100 psi} - 250 rpm Differential limit of chambers 150 kPa {1.5 kgf/cm ² , 21 psi} - 250 rpm	Yes	Go to next step
		No	Check for cause
7	Are spark plugs OK? ☞ Section G	Yes	Go to next step
		No	Clean or replace
8	Try Known good ECU, does condition improves? ☞ page F-150		

F

TROUBLESHOOTING GUIDE

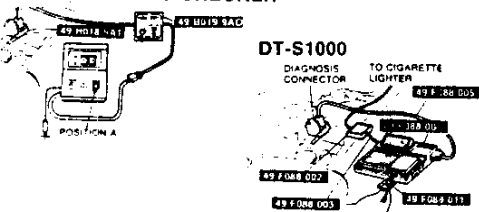



13, 14	ENGINE STALLS		<ul style="list-style-type: none"> ● IDLE WITH A/C, P/S, and/or E/L ON ● IDLE WHEN SHIFTED FROM N OR P TO OTHER RANGES
DESCRIPTION	<ul style="list-style-type: none"> ● Engine stops unexpectedly when A/C, P/S, and/or E/L turned ON at idle ● Engine stops unexpectedly when shifted from N or P to other ranges at idle ● Idle condition is normal when A/C, P/S, and E/L are OFF and in N and P 		
[TROUBLESHOOTING HINTS]			
① Monitor switch functions (SST) <ul style="list-style-type: none"> ● A/C switch ● Headlight switch ● Rear window defroster ● Blower switch 		② Solenoid valve (ISC) <ul style="list-style-type: none"> ● Solenoid valve stuck ③ Air control valve <ul style="list-style-type: none"> ● Malfunction of air control valve 	
STEP	INSPECTION		ACTION
1	Are switches correct when checked by using SST monitor switch function while ignition switch ON? ☞ page F-44 <ul style="list-style-type: none"> ● Blower switch ● Headlight switch ● Rear window defroster switch ● Electric cooling fan ● Electrical load unit ● A/C switch 	Yes	Go to next step
		No	Lamp not ON/OFF with specified switch Check for cause (Refer to specified check sequence) ☞ page F-45
2	Is "00" or "No service codes" displayed on SST with ignition switch ON? ☞ page F-20 SELF-DIAGNOSIS CHECKER 	Yes	"00" or "No service codes" displayed Go to next step
		No	Service Code No. displayed Check for cause (Refer to specified check sequence) ☞ page F-22
3	Is terminal voltage at ECU correct at idle? ☞ page F-150 4Q terminal: Approx. 5-11V (at Idle)	Yes	Check solenoid valve (ISC) and replace it if necessary ☞ page F-83 If OK, go to "ENGINE STALLS-IDLE WHEN SHIFTED FROM N or P TO OTHER RANGES" in Section K of this manual
		No	Try known good ECU and check if condition improves ☞ page F-150

15	ENGINE STALLS	● DRIVEAWAY								
DESCRIP-TION	<ul style="list-style-type: none"> ● Engine stops unexpectedly upon driveaway ● Idle condition normal 									
[TROUBLESHOOTING HINTS]										
<ul style="list-style-type: none"> ① Injector <ul style="list-style-type: none"> ● Fuel leakage from injector(s) ● Injector(s) clogged ② Pressure regulator <ul style="list-style-type: none"> ● diaphragm damaged ③ Fuel filter <ul style="list-style-type: none"> ● Fuel filter clogged ④ Metering oil pump <ul style="list-style-type: none"> ● Poor connection of connector ⑤ Water thermosensor <ul style="list-style-type: none"> ● Poor connection of connector ⑥ Crank angle sensor <ul style="list-style-type: none"> ● Malfunction of sensor 										
STEP	INSPECTION	ACTION								
1	Is "00" or "No service codes" displayed on SST with ignition switch ON? ↗ page F-20 	Yes "00" or "No service codes" displayed Go to next step								
		No Service Code No. displayed Check for cause (Refer to specified check sequence) ↗ page F-22								
2	Using Engine Signal Monitor, do voltage reading and lamp operation change as follows upon driveaway? <table border="1"> <thead> <tr> <th>Terminal</th> <th>Condition</th> </tr> </thead> <tbody> <tr> <td>1O</td> <td>Voltage gradually increase</td> </tr> <tr> <td>4D, 4E</td> <td>Voltage not suddenly change</td> </tr> <tr> <td>4W, 4Y</td> <td>Flashing of green and red lamps becomes quicker</td> </tr> </tbody> </table>	Terminal	Condition	1O	Voltage gradually increase	4D, 4E	Voltage not suddenly change	4W, 4Y	Flashing of green and red lamps becomes quicker	Yes Go to next step
		Terminal	Condition							
1O	Voltage gradually increase									
4D, 4E	Voltage not suddenly change									
4W, 4Y	Flashing of green and red lamps becomes quicker									
No Check as follows: <ul style="list-style-type: none"> ● Condition of female terminals in related connector ● Continuity between injector connector and ECU 4W or 4Y terminal 										
3	Connect diagnosis connector terminals F/P and GND with a jumper wire; is fuel line pressure correct with ignition switch ON? ↗ page F-98 Fuel line pressure: 250-260 kPa {2.5-2.7 kgf/cm ² , 36-38 psi} 	Yes Go to next step								
		No Low pressure Check fuel line pressure while pinching fuel return hose <ul style="list-style-type: none"> ● If pressure quickly increases, check pressure regulator ● If pressure gradually increases, check for clogging between fuel pump and pressure regulator If hose not clogged, check fuel pump maximum pressure ↗ page F-104 ↗ page F-101								
4	Are injectors OK? <ul style="list-style-type: none"> ● No fuel leakage ● Injectors not clogged (Perform volume test) ↗ page F-106 ↗ page F-67	Yes Go to next step								
		No Replace injector ↗ page F-105								

F

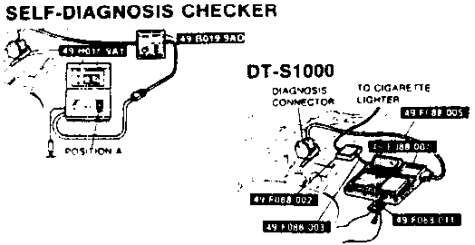
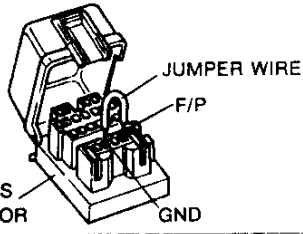
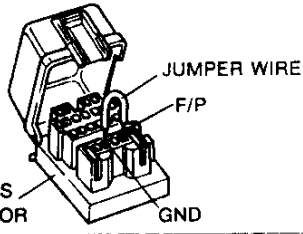
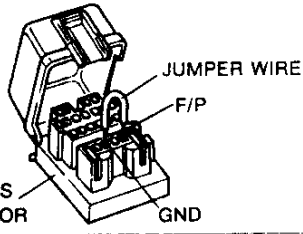

TROUBLESHOOTING GUIDE

STEP	INSPECTION		ACTION
5	Is engine compression OK? ☞ Section G Compression 690 kPa {7.0 kgf/cm ² , 100 psi} – 250 rpm Differential limit of chambers 150 kPa {1.5 kgf/cm ² , 21 psi} – 250 rpm	Yes	Go to next step
		No	Check for cause
6	Are spark plugs OK? ☞ Section G	Yes	Go to next step
		No	Clean or replace
7	Try known good ECU: does condition improve? ☞ page F-150		

16, 17	ENGINE STALLS	● ON ACCELERATION / WHILE CRUISING	
DESCRIPTION	<ul style="list-style-type: none"> ● Engine stops unexpectedly at beginning of acceleration or during acceleration ● Engine stops unexpectedly while cruising 		
[TROUBLESHOOTING HINTS]			
<div style="display: flex; justify-content: space-between;"> <div style="width: 45%;"> <p>① Fuel pump</p> <ul style="list-style-type: none"> ● Poor connection <p>② Pressure regulator</p> <ul style="list-style-type: none"> ● Diaphragm damaged <p>③ Crank angle sensor</p> <ul style="list-style-type: none"> ● Poor connection of connector </div> <div style="width: 45%;"> <p>④ Pressure sensor</p> <ul style="list-style-type: none"> ● Poor connection of connector <p>⑤ Spark plug</p> <ul style="list-style-type: none"> ● Misfire <p>⑥ Main relay</p> <ul style="list-style-type: none"> ● Poor connection of connector </div> </div>			
STEP	INSPECTION		ACTION
1	Is "00" or "No service codes" displayed on SST with ignition switch ON? 	Yes	"00" or "No service codes" displayed Go to next step
		No	Service Code No. displayed Check for cause (Refer to specified check sequence)
2	Ground terminal F/P of diagnosis connector within ignition switch ON; does condition improve? 	Yes	Check as follows; <ul style="list-style-type: none"> ● Poor connection of circuit opening relay ● Poor connection of ECU 1T terminal
		No	Go to next step
3	Is pressure regulator OK? 	Yes	Go to next step
		No	Replace
4	Try known good ECU; does condition improved? 		

F

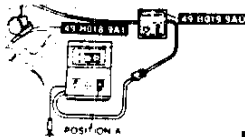
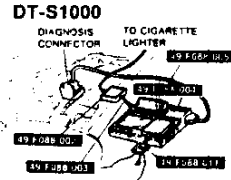
TROUBLESHOOTING GUIDE

18	ENGINE STALLS	● ON DECELERATION
DESCRIP-TION	<ul style="list-style-type: none"> ● Engine stops unexpectedly at beginning of deceleration or recovery from deceleration ● Exhaust afterburn 	
[TROUBLESHOOTING HINTS]		
<ul style="list-style-type: none"> ① Fuel pump <ul style="list-style-type: none"> ● Poor connection of connector ② Idle speed <ul style="list-style-type: none"> ● Idle speed too low ③ Crank angle sensor <ul style="list-style-type: none"> ● Poor connection of connector ④ Pressure sensor <ul style="list-style-type: none"> ● Malfunction of pressure sensor ⑤ Solenoid valve (ISC) <ul style="list-style-type: none"> ● Solenoid valve stuck ⑥ EGR control valve <ul style="list-style-type: none"> ● Solenoid valve stuck open ⑦ ECU <ul style="list-style-type: none"> ● Poor connection of connector ⑧ Fuel cut control 		
STEP	INSPECTION	ACTION
1	Is "00" or "No service codes" displayed on SST with ignition switch ON    page F-20	Yes "00" or "No service codes" displayed Go to next step
		No Service Code No. displayed Check for cause (Refer to specified check sequence)
2	Are following ECU terminal voltage correct? Note When checking voltages, tap, move, and wiggle harness and connector <ul style="list-style-type: none"> ● 1B (Main relay) ● 1G, 1H, 1J (Igniter) ● 1T (Circuit opening relay) ● 4D (Ground) ● 4W, 4Y (Primary injector) 	Yes MT Check neutral switch and clutch switch  page F-186 AT Go to "ENGINE STALLS ON DECELERATION" in Section K of this manual
		No Check for cause

TROUBLESHOOTING GUIDE

F

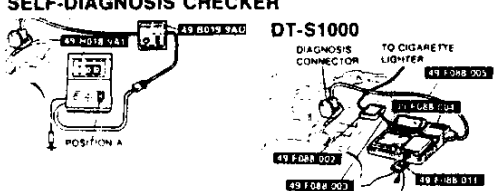
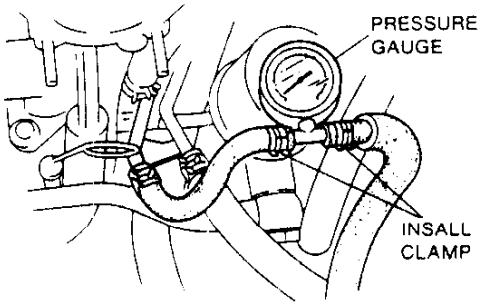







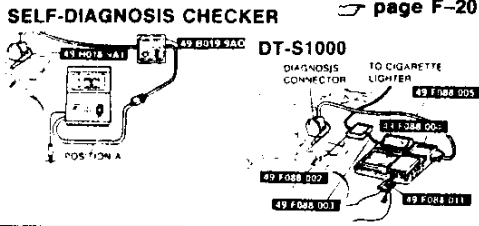

19, 20, 21	ENGINE ROUGH	● IDLE AT ANY ENGINE TEMP / DURING FAST IDLE / IDLE AFTER WARM-UP	
DESCRIP-TION	<ul style="list-style-type: none"> ● Engine speed fluctuates between specified idle speed and lower speed and excessive engine shake at any engine temperature ● Idle speed too low and excessive engine shake at any engine temperature ● Fast idle speed too low and excessive engine shake during fast idle, but returns to normal after warm-up ● Engine speed fluctuates between specified idle speed and lower speed and excessive engine shake at idle after warm-up 		
[TROUBLESHOOTING HINTS]			
<div style="display: flex; justify-content: space-between;"> <div style="width: 48%;"> <p>① Injector</p> <ul style="list-style-type: none"> ● Fuel leakage from injector(s) ● Injector(s) clogged <p>② Air pump</p> <ul style="list-style-type: none"> ● Malfunction of air pump <p>③ Circuit opening relay</p> <ul style="list-style-type: none"> ● Poor connection of connector <p>④ Spark plug</p> <ul style="list-style-type: none"> ● Misfire <p>⑤ Engine</p> <ul style="list-style-type: none"> ● Compression low </div> <div style="width: 48%;"> <p>⑥ Fast idle cam</p> <ul style="list-style-type: none"> ● Malfunction of fast idle cam <p>⑦ Pressure sensor</p> <ul style="list-style-type: none"> ● Malfunction of pressure sensor <p>⑧ Water therosensor</p> <ul style="list-style-type: none"> ● Poor connection of connector <p>⑨ EGR control valve</p> <ul style="list-style-type: none"> ● EGR control valve stuck <p>⑩ Solenoid valve (ISC)</p> <ul style="list-style-type: none"> ● Poor connection of connector <p>⑪ Fuel therosensor</p> </div> </div>			
STEP	INSPECTION		ACTION
1	Is "00" or "No service codes" displayed on SST with ignition switch ON ?  <p style="text-align: right;">➤ page F-20</p>	Yes	"00" or "No service codes" displayed Go to next step
	No	No	Service Code No. displayed Check for cause (Refer to specified check sequence) ➤ page F-22
2	Are spark plugs OK?	Yes	Go to next step
		No	Clean or replace
3	Is strong blue spark visible at each disconnected high-tension lead at idle?	Yes	Go to next step
		No	Check ignition system ➤ Section G
4	Connect diagnosis connector terminals F/P and GND with a jumper wire; is fuel line pressure correct with ignition switch ON?  <p style="text-align: right;">➤ page F-98</p>	Yes	<ul style="list-style-type: none"> ● If symptom occurs at idle at any engine temperature, go to next step ● If symptom occurs during fast idle operation, go to Step 6 ● If symptom occurs at idle after warm-up, go to Step 10
		No	Low pressure Check fuel line pressure while pinching fuel return hose <ul style="list-style-type: none"> ● If pressure quickly increases, check pressure regulator ● If pressure gradually increases, check for clogging between fuel pump and pressure regulator If hose not clogged, check fuel pump maximum pressure ➤ page F-10-1 ➤ page F-10
5	Is air pump OK? ➤ page F-121	Yes	Go to next step
		No	Repair or replace

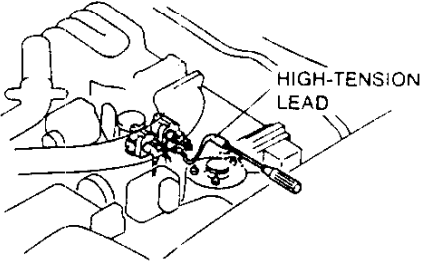



F

TROUBLESHOOTING GUIDE

STEP	INSPECTION		ACTION
6	Is solenoid valve (ISC) OK? ☞ page F-83	Yes	Go to next step
		No	Repair or replace
7	Is fast idle cam OK? ☞ page F-79	Yes	Go to next step
		No	Adjust
8	Is accelerated warm-up system OK? ☞ page F-83	Yes	Go to next step
		No	Repair or replace
9	Is engine compression correct? ☞ Section C Compression 690 kPa (7.0 kgf/cm², 100 psi) – 250 rpm Differential limit of chambers 150 kPa (1.5 kgf/cm², 21 psi) – 250 rpm	Yes	Go to next step
		No	Check for cause ☞ Section G
10	Are following ECU terminal voltages correct? ☞ page F-152 <ul style="list-style-type: none"> ● 1O (Pressure sensor) ● 3E (Water thermostat sensor) ● 3L (Intake air thermostat sensor) ● 4I, 4J, 4K, 4L (Metering oil pump) ● 4Y (Rear primary injector) ● 4W (Front primary injector) 	Yes	Go to next step
		No	Check for cause
11	Is EGR control system OK? ☞ page F-126	Yes	Try known good ECU; does condition improve? ☞ page F-150
		No	Repair or replace

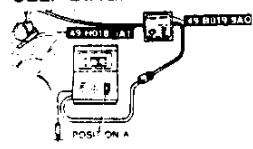
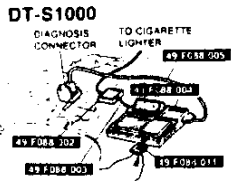
22, 23	ENGINE ROUGH	<ul style="list-style-type: none"> ● IDLE WITH A/C, P/S AND/OR E/L ON ● IDLE WHEN SHIFTED FROM N OR P TO OTHER RANGES
DESCRIPTION	<ul style="list-style-type: none"> ● Engine speed fluctuates between specified idle speed and lower speed and excessive engine shake at idle when A/C, P/S and/or E/L ON ● Engine speed fluctuates between specified idle speed and lower speed and excessive engine shake at idle when shifted from P or N to other range 	
[TROUBLESHOOTING HINTS]		
<div style="display: flex; justify-content: space-between;"> <div style="width: 45%;"> <p>① Idle speed</p> <ul style="list-style-type: none"> ● Idle speed too low <p>② Monitor switch function (SST)</p> <ul style="list-style-type: none"> ● A/C switch ● Headlight switch ● Rear window defroster switch ● Blower switch </div> <div style="width: 45%;"> <p>③ Solenoid valve (ISC)</p> <ul style="list-style-type: none"> ● Solenoid valve stuck </div> </div>		
STEP	INSPECTION	ACTION
1	Is idle speed correct? page F-16	Yes: Go to next step No: Adjust page F-16
	Is "00" or "No service codes" displayed on SST with ignition switch ON? page F-20	Yes: "00" or "No service codes" displayed Go to next step No: Service Code No. displayed Check for cause (Refer to specified check sequence) page F-22
3	Are following terminal voltage at ECU correct? page F-1 <ul style="list-style-type: none"> ● 1E (A/C switch) ● 1N (P/S pressure switch) ● 1R (EC-AT control unit) [AT] ● 3B (Electrical load unit) ● 3D (Electrical cooling fan) 	Yes: Go to next step No: Check for cause
	Warm-up engine Does idle speed decrease when solenoid valve (ISC) connector disconnected?	Yes: <ul style="list-style-type: none"> ● If symptom occurs at idle with A/C ON, check A/C system in Section U of this manual ● If symptom occurs at idle with E/L ON, check E/L unit ● If symptom occurs at idle with P/S ON, check P/S pump in Section N of this manual ● If symptom occurs at idle when shifted from N or P to other range, go to "ENGINE ROUGH-IDLE WHEN SHIFTED FROM N OR P TO OTHER RANGE" in Section K of this manual (AT) page F-13
5	No: Check fast idle cam page F-79	No: Check fast idle cam page F-79

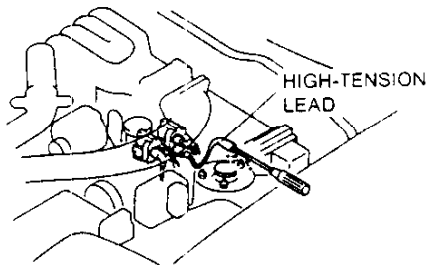
24	ENGINE ROUGH	● ON DECELERATION
DESCRIPTION	<ul style="list-style-type: none"> ● Engine shakes at beginning of deceleration, or recovery from deceleration ● Exhaust afterburn. 	
[TROUBLESHOOTING HINTS]		
<ul style="list-style-type: none"> ① Fuel pump <ul style="list-style-type: none"> ● Poor connection of connector ② Injector <ul style="list-style-type: none"> ● Fuel leakage from injector(s) ③ Dashpot <ul style="list-style-type: none"> ● Dashpot misadjusted ④ Throttle sensor <ul style="list-style-type: none"> ● Poor connection of connector ⑤ Secondary air injection system ⑥ Solenoid valve (ISC) <ul style="list-style-type: none"> ● Solenoid valve stuck 		
STEP	INSPECTION	ACTION
1	Is "00" or "No service codes" displayed on SST with ignition switch ON? SELF-DIAGNOSIS CHECKER  page F-20	Yes "00" or "No service codes" displayed Go to next step
		No Service Code No. displayed Check for cause (Refer to specified check sequence)  page F-22
2	Is strong blue spark visible at each disconnected high-tension lead?  HIGH-TENSION LEAD	Yes Check spark plugs If OK, go to next step If not OK, clean or replace spark plug
		No Check ignition system  Section G
3	Is dashpot OK?  page F-134	Yes Go to next step No Adjust
4	Is intake manifold vacuum correct at idle? Vacuum: More than 60.0 kPa {450 mmHg, 17.7 inHg}	Yes Go to next step No Check as follows: <ul style="list-style-type: none"> ● Intake air system components for proper installation ● Vacuum hoses for disconnection and damage ● Engine compression  Section C
5	Are injectors OK?  page F-106	Yes Go to next step No Replace
6	Is engine compression OK?  Section C Compression 690 kPa {7.0 kgf/cm², 100 psi} – 250 rpm Differential limit of chambers 150 kPa {1.5 kgf/cm², 21 psi} – 250 rpm	Yes Go to next step No Check for cause  Section C
7	Try known good ECU; does condition improve?  page F-150	

25, 26	POOR ACCELERATION	● DRIVEAWAY ● ON ACCELERATION			
DESCRIP-TION	● Engine speed increases normally but vehicle speed slowly increases during driveaway or acceleration				
[TROUBLESHOOTING HINTS]					
<table border="0"> <tr> <td style="vertical-align: top;"> <ul style="list-style-type: none"> ① Injector <ul style="list-style-type: none"> ● Fuel leakage from injector(s) ● Injector nozzle clogged ② Pressure regulator <ul style="list-style-type: none"> ● Pressure regulator malfunction ③ Fuel filter <ul style="list-style-type: none"> ● Filter clogged ④ Spark plug <ul style="list-style-type: none"> ● Misfire ⑤ Igniter <ul style="list-style-type: none"> ● Poor connection of connector ⑥ Air leakage in intake air system ⑦ Pressure sensor <ul style="list-style-type: none"> ● Pressure sensor filter or hose clogged ● Poor connection of connector </td> <td style="vertical-align: top;"> <ul style="list-style-type: none"> ⑧ Crank angle sensor <ul style="list-style-type: none"> ● Poor connection of connector ⑨ Metering oil pump <ul style="list-style-type: none"> ● Malfunction of oil pump (Fuel injection amount and ignition timing fixed) ⑩ Solenoid valve (Turbo control, Charge control) <ul style="list-style-type: none"> ● Malfunction of solenoid valve (Fuel injection amount and ignition timing fixed) ⑪ EGR control system <ul style="list-style-type: none"> ● EGR control valve stuck (open) ⑫ Water thermosensor <ul style="list-style-type: none"> ● Malfunction of thermosensor ⑬ Double throttle control system </td> </tr> </table>				<ul style="list-style-type: none"> ① Injector <ul style="list-style-type: none"> ● Fuel leakage from injector(s) ● Injector nozzle clogged ② Pressure regulator <ul style="list-style-type: none"> ● Pressure regulator malfunction ③ Fuel filter <ul style="list-style-type: none"> ● Filter clogged ④ Spark plug <ul style="list-style-type: none"> ● Misfire ⑤ Igniter <ul style="list-style-type: none"> ● Poor connection of connector ⑥ Air leakage in intake air system ⑦ Pressure sensor <ul style="list-style-type: none"> ● Pressure sensor filter or hose clogged ● Poor connection of connector 	<ul style="list-style-type: none"> ⑧ Crank angle sensor <ul style="list-style-type: none"> ● Poor connection of connector ⑨ Metering oil pump <ul style="list-style-type: none"> ● Malfunction of oil pump (Fuel injection amount and ignition timing fixed) ⑩ Solenoid valve (Turbo control, Charge control) <ul style="list-style-type: none"> ● Malfunction of solenoid valve (Fuel injection amount and ignition timing fixed) ⑪ EGR control system <ul style="list-style-type: none"> ● EGR control valve stuck (open) ⑫ Water thermosensor <ul style="list-style-type: none"> ● Malfunction of thermosensor ⑬ Double throttle control system
<ul style="list-style-type: none"> ① Injector <ul style="list-style-type: none"> ● Fuel leakage from injector(s) ● Injector nozzle clogged ② Pressure regulator <ul style="list-style-type: none"> ● Pressure regulator malfunction ③ Fuel filter <ul style="list-style-type: none"> ● Filter clogged ④ Spark plug <ul style="list-style-type: none"> ● Misfire ⑤ Igniter <ul style="list-style-type: none"> ● Poor connection of connector ⑥ Air leakage in intake air system ⑦ Pressure sensor <ul style="list-style-type: none"> ● Pressure sensor filter or hose clogged ● Poor connection of connector 	<ul style="list-style-type: none"> ⑧ Crank angle sensor <ul style="list-style-type: none"> ● Poor connection of connector ⑨ Metering oil pump <ul style="list-style-type: none"> ● Malfunction of oil pump (Fuel injection amount and ignition timing fixed) ⑩ Solenoid valve (Turbo control, Charge control) <ul style="list-style-type: none"> ● Malfunction of solenoid valve (Fuel injection amount and ignition timing fixed) ⑪ EGR control system <ul style="list-style-type: none"> ● EGR control valve stuck (open) ⑫ Water thermosensor <ul style="list-style-type: none"> ● Malfunction of thermosensor ⑬ Double throttle control system 				
STEP	INSPECTION	ACTION			
1	Is "00" or "No service codes" displayed on SST with ignition switch ON?  <p>SELF-DIAGNOSIS CHECKER</p>  <p>DT-S1000 DIAGNOSIS CONNECTOR TO CIGARETTE LIGHTER</p>	Yes	"00" or "No service codes" displayed Go to next step		
		No	Service Code No. displayed Check for cause (Refer to specified check sequence)  page F-22		
2	Is a strong blue spark visible at each disconnected high-tension lead while cranking engine?  <p>HIGH-TENSION LEAD</p>	Yes	Check spark plugs If OK, go to next step If not OK, clean or replace spark plug		
		No	Check ignition system  Section G		
3	Is intake manifold vacuum correct at idle? Vacuum: More than 60.0 kPa (450 mmHg, 17.7 inHg)	Yes	Go to next step		
		No	Check as follows: ● Intake air system components and installation ● Vacuum hoses for disconnection and damage ● Engine compression  Section C		
4	Is air leakage felt or heard at intake air system components?	Yes	Repair or replace		
		No	Go to next step		

F

TROUBLESHOOTING GUIDE

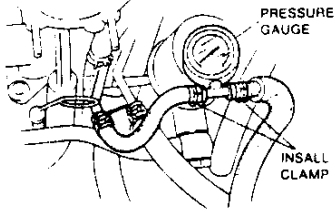
STEP	INSPECTION	ACTION	
5	<p>Is fuel line pressure correct at idle?</p> <p style="text-align: right;">☞ page F-98</p> <p>Fuel line pressure: 190-220 kPa (1.9-2.3 kgf/cm², 28-32 psi)</p>  <p style="text-align: center;">PRESSURE GAUGE</p> <p style="text-align: center;">INSTALL CLAMP</p>	Yes	Go to next step
		No	<p>Low pressure</p> <p>Check as follows:</p> <ul style="list-style-type: none"> ● Fuel filter for clogging ● Operation of pressure regulator
6	<p>Are injectors OK?</p> <p style="text-align: right;">☞ page F-106</p>	Yes	<p>MT</p> <p>Go to next step</p> <p>AT</p> <p>Go to "POOR ACCELERATION - DRIVEAWAY / ON ACCELERATION" in Section K of this manual</p>
		No	Replace
7	<p>Try known good ECU; does condition improve?</p> <p style="text-align: right;">☞ page F-150</p>		

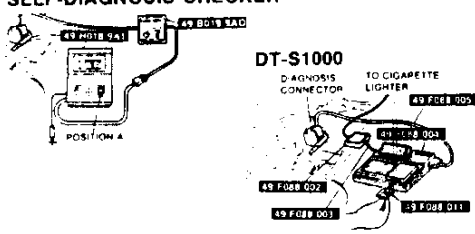
27	HIGH IDLE SPEED AFTER WARM-UP	
DESCRIP- TION	<ul style="list-style-type: none"> ● Idle speed continues at fast idle after warm-up ● Engine returns slowly to idle after accelerator is released 	
[TROUBLESHOOTING HINTS]		
<ul style="list-style-type: none"> ① Fast idle cam <ul style="list-style-type: none"> ● Malfunction of fast idle cam ② Accelerated warm-up system <ul style="list-style-type: none"> ● Solenoid valve (AWS) open ③ Water thermosensor <ul style="list-style-type: none"> ● Malfunction of water thermosensor 	<ul style="list-style-type: none"> ④ Solenoid valve (ISC) <ul style="list-style-type: none"> ● Solenoid valve (ISC) stuck (open) ● A/C, P/S, or E/L signal always ON ⑤ Throttle valve <ul style="list-style-type: none"> ● Valve not fully closed ⑥ Dashpot 	
STEP	INSPECTION	ACTION
1	Is "00" or "No service codes" displayed on SST with ignition switch ON? 	Yes "00" or "No service codes" displayed Go to next step No Service Code No. displayed Check for cause (Refer to specified check sequence)
2	Connect diagnosis connector terminals TEN and GND with a jumper wire; does idle speed decrease?	Yes Check following terminal voltage at ECU ● 1E (A/C switch) ● 1N (P/S pressure switch) ● 3B (Electrical load unit) No Go to next step
3	Are following terminal voltage at ECU correct? ● 1E (A/C switch) ● 1O (Pressure sensor) ● 3B (Electric load unit) ● 3E (Water thermosensor) ● 3F (Throttle sensor-Narrow range) ● 3L (Intake air thermosensor) ● 4P (Solenoid valve (AWS)) ● 4Q (Solenoid valve (ISC))	Yes Go to next step No Check for cause
4	Is throttle valve fully closed?	Yes Go to next step No Check following devices ● Accelerator cable linkage ● Throttle lever ● Accelerator pedal ● Fast idle cam

F**TROUBLESHOOTING GUIDE**

STEP	INSPECTION	ACTION	
5	Is solenoid valve (AWS) OK? <input type="checkbox"/> page F-83	Yes	Go to next step
		No	Repair
6	Is water thermosensor OK? <input type="checkbox"/> page F-183	Yes	Go to next step
		No	Replace
7	Try known good ECU: does condition improved? <input type="checkbox"/> page F-150		

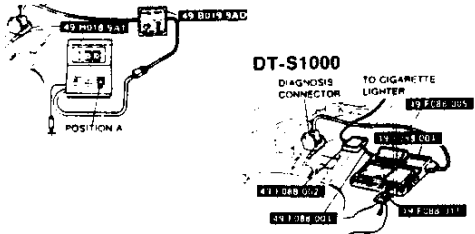
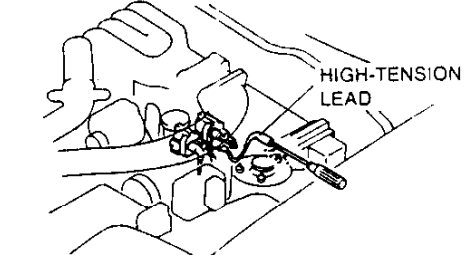
28	<ul style="list-style-type: none"> ● IDLE FLUCTUATES ● IDLE HUNTS 	
DESCRIP-TION	<ul style="list-style-type: none"> ● Engine speed changes back and forth between specified idle speed and higher speed 	
[TROUBLESHOOTING HINTS]		
<ul style="list-style-type: none"> ① PCV valve <ul style="list-style-type: none"> ● PCV valve stuck ② Spark plug <ul style="list-style-type: none"> ● Dirty or worn spark plug(s) ③ Throttle sensor <ul style="list-style-type: none"> ● Incorrect adjustment 	<ul style="list-style-type: none"> ④ Solenoid valve (ISC) <ul style="list-style-type: none"> ● Solenoid valve stuck ⑤ Intake air system <ul style="list-style-type: none"> ● Air leakage 	
STEP	INSPECTION	ACTION
1	<p>Is "00" or "No service codes" displayed on SST with ignition switch ON?</p> <p>☞ page F-20</p> <p>SELF-DIAGNOSIS CHECKER</p> 	<p>Yes "00" or "No service codes" displayed</p> <p>Go to next step</p> <p>No Service Code No. displayed</p> <p>Check for cause (Refer to specified check sequence)</p> <p>☞ page F-22</p>
2	<p>Is a strong blue spark visible at each disconnected high-tension lead while cranking engine?</p> 	<p>Yes Check spark plug(s)</p> <p>If OK, go to next step</p> <p>If not OK clean or, replace spark plug(s)</p> <p>No Check as follows:</p> <ul style="list-style-type: none"> ● Ignition coils ● Igniter ● High tension leads ● ECU 1G, 1H, 1J terminal voltage <p>☞ Section G</p>
3	<p>Is air leakage felt or heard at intake air system components?</p>	<p>Yes Repair or replace</p> <p>No Go to next step</p>
4	<p>Is PCV valve stuck?</p> <p>☞ page F-124</p>	<p>Yes Replace PCV valve</p> <p>No Go to next step</p>
5	<p>Is solenoid valve (ISC) OK?</p> <p>☞ page F-83</p>	<p>Yes Go to next step</p> <p>No Replace</p>
6	<p>Is fuel line pressure correct at idle?</p> <p>☞ page F-98</p> <p>Fuel line pressure: 190-220 kPa (1.9-2.3 kgf/cm², 28-32 psi)</p>	<p>Yes Go to next step</p> <p>No Low pressure</p> <p>Check as follows:</p> <ul style="list-style-type: none"> ● Fuel filter for clogging ● Operation of pressure regulator
7	<p>Try known good ECU, does condition improved?</p> <p>☞ page F-150</p>	

F

TROUBLESHOOTING GUIDE

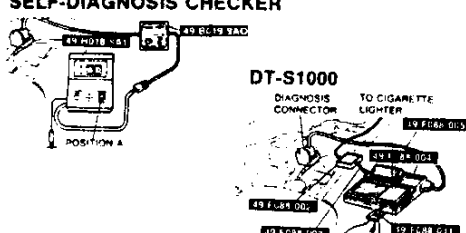
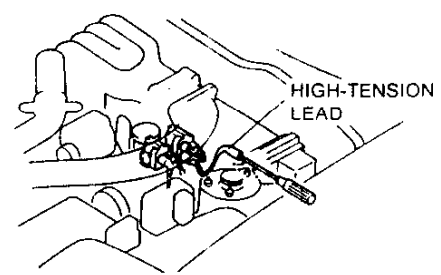
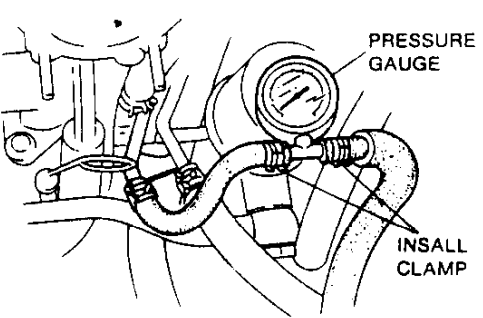
29	<ul style="list-style-type: none"> ● HESITATES ● STUMBLES ON ACCELERATION 		
DESCRIP-TION	<ul style="list-style-type: none"> ● Momentary pause at beginning of acceleration or during acceleration 		
[TROUBLESHOOTING HINTS]			
<table border="0"> <tr> <td style="vertical-align: top;"> <ul style="list-style-type: none"> ① Injector <ul style="list-style-type: none"> ● Fuel leakage from injector(s) ② Pressure regulator <ul style="list-style-type: none"> ● Pressure regulator stuck ③ High-tension lead <ul style="list-style-type: none"> ● Lead damaged ④ Spark plug <ul style="list-style-type: none"> ● Dirty or worn spark plug(s) ⑤ Pressure sensor <ul style="list-style-type: none"> ● Malfunction of pressure sensor </td> <td style="vertical-align: top; padding-left: 20px;"> <ul style="list-style-type: none"> ⑥ EGR control valve <ul style="list-style-type: none"> ● EGR control valve stuck ⑦ Double throttle control <ul style="list-style-type: none"> ● Double throttle valve stuck </td> </tr> </table>		<ul style="list-style-type: none"> ① Injector <ul style="list-style-type: none"> ● Fuel leakage from injector(s) ② Pressure regulator <ul style="list-style-type: none"> ● Pressure regulator stuck ③ High-tension lead <ul style="list-style-type: none"> ● Lead damaged ④ Spark plug <ul style="list-style-type: none"> ● Dirty or worn spark plug(s) ⑤ Pressure sensor <ul style="list-style-type: none"> ● Malfunction of pressure sensor 	<ul style="list-style-type: none"> ⑥ EGR control valve <ul style="list-style-type: none"> ● EGR control valve stuck ⑦ Double throttle control <ul style="list-style-type: none"> ● Double throttle valve stuck
<ul style="list-style-type: none"> ① Injector <ul style="list-style-type: none"> ● Fuel leakage from injector(s) ② Pressure regulator <ul style="list-style-type: none"> ● Pressure regulator stuck ③ High-tension lead <ul style="list-style-type: none"> ● Lead damaged ④ Spark plug <ul style="list-style-type: none"> ● Dirty or worn spark plug(s) ⑤ Pressure sensor <ul style="list-style-type: none"> ● Malfunction of pressure sensor 	<ul style="list-style-type: none"> ⑥ EGR control valve <ul style="list-style-type: none"> ● EGR control valve stuck ⑦ Double throttle control <ul style="list-style-type: none"> ● Double throttle valve stuck 		
STEP	INSPECTION	ACTION	
1	<p>Is "00" or "No service codes" displayed on SST with ignition switch ON?</p> <p style="text-align: right;">☞ page F-20</p> <p>SELF-DIAGNOSIS CHECKER</p> 	<p>"00" or "No service codes" displayed</p> <p>Go to next step</p> <p>No</p> <p>Service Code No. displayed</p> <p>Check for cause (Refer to specified check sequence)</p> <p style="text-align: right;">☞ page F-22</p>	
2	<p>Is strong blue spark visible at each disconnected high-tension lead at idle?</p> 	<p>Yes</p> <p>Check spark plug(s)</p> <p>If OK, go to next step</p> <p>If not OK, clean or replace spark plug(s)</p> <p>No</p> <p>Check ignition system</p> <p style="text-align: right;">☞ Section G</p>	
3	<p>Is fuel line pressure correct at idle?</p> <p style="text-align: right;">☞ page F-104</p> <p>Fuel line pressure 190-220 kPa (1.9-2.3 kgf/cm², 28-32 psi)</p> 	<p>Yes</p> <p>Go to next step</p> <p>No</p> <p>Low pressure</p> <p>Check fuel line pressure while pinching fuel return hose</p> <ul style="list-style-type: none"> ● If pressure quickly increases, check pressure regulator ● If pressure gradually increases, check for clogging between fuel pump and pressure regulator <p>If hose not clogged, check fuel pump maximum pressure</p> <p style="text-align: right;">☞ page F-104</p> <p style="text-align: right;">☞ page F-101</p>	

TROUBLESHOOTING GUIDE

F

STEP	INSPECTION		ACTION
4	Does fuel pressure increase when throttle valve opened? (engine running)	Yes	Go to next step
		No	Check pressure regulator ☞ page F-104
5	Are following terminal voltage at ECU correct? ☞ page F-154 1O (Pressure sensor) 3F (Throttle sensor-Full range) 3G (Throttle sensor-Narrow range) 3K (Solenoid valve (Relief 2)) 3O (Solenoid valve (Double throttle)) 3P (Solenoid valve (Relief 1)) 4E (Crank angle sensor (NE)) 4I, 4J, 4K, 4L (Metering oil pump) 4O (Solenoid valve (EGR)) 4R (Solenoid valve (Turbo control)) 4S (Solenoid valve (Charge relief)) 4T (Solenoid valve (Charge control)) 4V (Solenoid valve (Turbo precontrol)) 4W, 4X, 4Y, 4Z (Fuel injector)	Yes	Go to next step
		No	Check for cause ☞ page F-155
6	Are injectors OK? ☞ page F-106	Yes	Go to next step
		No	Repair or replace
7	Is EGR control system OK? ☞ page F-126		
8	Try known good ECU: does condition improve? ☞ page F-150		

F

TROUBLESHOOTING GUIDE

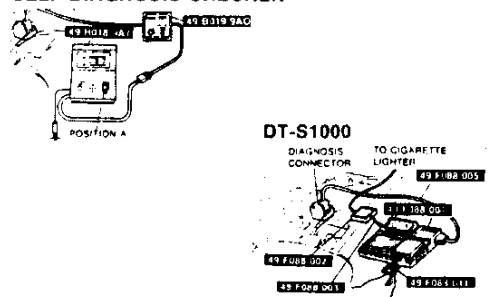
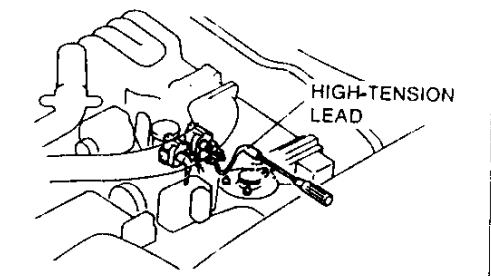
30	SURGES WHILE CRUISING	
DESCRIP-TION	● Momentary minor irregularity in engine power at steady vehicle speed.	
[TROUBLESHOOTING HINTS]		
<ul style="list-style-type: none"> ① Injector <ul style="list-style-type: none"> ● Poor connection of connector ② Spark plug <ul style="list-style-type: none"> ● Dirty or worn spark plug(s) ③ Pressure sensor <ul style="list-style-type: none"> ● Poor connection of connector 		<ul style="list-style-type: none"> ④ Igniter <ul style="list-style-type: none"> ● Poor connection of connector ⑤ Ignition coil <ul style="list-style-type: none"> ● Malfunction of ignition coil ⑥ Throttle sensor
STEP	INSPECTION	ACTION
1	Is "00" or "No service codes" displayed on SST with ignition switch ON? ☞ page F-20 SELF-DIAGNOSIS CHECKER 	Yes: "00" or "No service codes" displayed Go to next step No: Service Code No. displayed Check for cause (Refer to specified check sequence) ☞ page F-22
2	Is strong blue spark visible at each disconnected high-tension lead while cranking engine? 	Yes: Check spark plug(s) for damage If OK, go to next step If not OK, replace spark plug(s) No: Check ignition system ☞ Section G
3	Does idle become rough when shaking connector of following devices? <ul style="list-style-type: none"> ● Injector ● Igniter ● Ignition coil ● Crank angle sensor 	Yes: Check condition of connector No: Go to next step
4	Are following terminal voltage at ECU correct? ☞ page F-158 <ul style="list-style-type: none"> ● 1G, 1H, 1J (Igniter) ● 3G (Throttle sensor-Full range) ● 4O (Solenoid valve (EGR)) ● 4R (Solenoid valve (Turbo control)) ● 4S (Solenoid valve (Charge relief)) ● 4V (Solenoid valve (Turbo precontrol)) ● 4W, 4X, 4Y, 4Z (Injector) 	Yes: Go to next step No: Check for cause ☞ page F-159
5	Try known good ECU; does condition improve? ☞ page F-150	

31	LACK OF POWER
DESCRIPTION	<ul style="list-style-type: none"> ● Performance poor under load (i.e., power down when climbing hills)
[TROUBLESHOOTING HINTS]	
<ul style="list-style-type: none"> ① Pressure sensor <ul style="list-style-type: none"> ● Malfunction of pressure sensor ② Secondary injector <ul style="list-style-type: none"> ● Poor connection of connector ● Nozzle clogged ③ Air leakage <ul style="list-style-type: none"> ● Turbo boost leakage ④ Spark plug <ul style="list-style-type: none"> ● Dirty or worn spark plug(s) ⑤ Throttle sensor (Full range) <ul style="list-style-type: none"> ● Malfunction of throttle sensor ⑥ Fuel filter <ul style="list-style-type: none"> ● Filter clogged ⑦ Pressure regulator <ul style="list-style-type: none"> ● Malfunction of pressure regulator 	<ul style="list-style-type: none"> ⑧ Double throttle control system <ul style="list-style-type: none"> ● Double throttle valve not open ⑨ Sequential twin turbo control system <ul style="list-style-type: none"> ● Secondary port not open ⑩ EGR control system <ul style="list-style-type: none"> ● EGR control valve stuck (open) ⑪ Air cleaner <ul style="list-style-type: none"> ● Clogged element ⑫ Catalytic converter <ul style="list-style-type: none"> ● Clogged catalytic converter ⑬ Fuel <ul style="list-style-type: none"> ● Low octane fuel used ⑭ Metering oil pump <ul style="list-style-type: none"> ● Poor connection of connector

32	POOR FUEL ECONOMY
DESCRIPTION	<ul style="list-style-type: none"> ● Fuel economy unsatisfactory
[TROUBLESHOOTING HINTS]	
<ul style="list-style-type: none"> ① Engine compression <ul style="list-style-type: none"> ● Compression low ② Spark plug(s) <ul style="list-style-type: none"> ● Dirty or worn spark plug(s) ③ Ignition coil <ul style="list-style-type: none"> ● Malfunction of ignition coil ④ Pressure regulator <ul style="list-style-type: none"> ● Malfunction of pressure regulator ⑤ Intake air leakage <ul style="list-style-type: none"> ● Air hose damaged or disconnected 	

33	A/C DOES NOT WORK
DESCRIPTION	<ul style="list-style-type: none"> ● A/C compressor magnetic clutch does not engage when A/C switch ON
[TROUBLESHOOTING HINTS]	
<ul style="list-style-type: none"> ① A/C relay <ul style="list-style-type: none"> ● Poor connection of connector ● Relay malfunction ② A/C switch <ul style="list-style-type: none"> ● Does not send signal to ECU terminal 1E ③ ECU <ul style="list-style-type: none"> ● ECU 1L terminal circuit open 	<ul style="list-style-type: none"> ☞ Section U ☞ page F-152 ☞ page F-154

16E0F2-2 32

F

TROUBLESHOOTING GUIDE

34	<ul style="list-style-type: none"> ● KNOCKING ● PINGING
DESCRIP- TION	<ul style="list-style-type: none"> ● Sound produced when air/fuel mixture is ignited by something other than spark plug (i.e., hot spot in combustion chamber)
[TROUBLESHOOTING HINTS]	
Knock sensor	
<ul style="list-style-type: none"> ● Open or short in harness (Code No.05 output) 	
page F-165	

16E0F 2-283

35	FUEL ODOR
DESCRIP- TION	<ul style="list-style-type: none"> ● Gasoline smell or visible leaks
[TROUBLESHOOTING HINTS]	
① Solenoid valve (purge control)	
<ul style="list-style-type: none"> ● Open harness (Code No.26 output) 	
② Charcoal canister	
<ul style="list-style-type: none"> ● Canister full of fuel and leaking 	
page F-131	

16E0F 2-284

36	EXHAUST SULFUR SMELL
DESCRIP- TION	<ul style="list-style-type: none"> ● Rotten egg smell (sulfur) from exhaust
[TROUBLESHOOTING HINTS]	
High sulfur content fuel used	

16E0F 2-285

37	HIGH OIL CONSUMPTION
DESCRIP- TION	<ul style="list-style-type: none"> ● Oil consumption excessive
[TROUBLESHOOTING HINTS]	
① Metering oil pump	
<ul style="list-style-type: none"> ● Malfunction of metering oil pump ● Open or short in wiring harness 	
② PCV valve	
<ul style="list-style-type: none"> ● PCV valve stuck open 	
Section D	
page F-124	

TROUBLESHOOTING GUIDE

F

38	SELF-DIAGNOSIS CHECKER FLASHES 88 / DT-S1000 INDICATES "SYSTEM ERROR"
DESCRIP- TION	<ul style="list-style-type: none">● Checker flashes 88 with test connector (TEN) grounded● DT-S1000 indicates "System error"
[TROUBLESHOOTING HINTS]	
<ul style="list-style-type: none">① Short circuit in wiring between diagnosis connector terminal FEN and ECU terminal 1F② ECU malfunction	

16E0F 2-287

39	MIL NEVER ON
DESCRIP- TION	<ul style="list-style-type: none">● Self-Diagnosis Checker or DT-S1000 indicates Service Code No. of input device but MIL never ON
[TROUBLESHOOTING HINTS]	
<ul style="list-style-type: none">① Bulb burnt② Electrical load unit 1K terminal circuit open	

page F-135

16E0F 2-288

SERVICE POINTS**OUTLINE****[Power and Ground]****ECU ground (Injector)**

- An open circuit will not produce any symptom.
- If the ECU ground (Output devices) circuit also has an open, the engine will not start.

ECU ground (Output devices)

- An open circuit will not produce any symptom.
- If ECU ground (Injector) circuit also has an open, the engine will not start.

ECU ground (System)

- An open circuit will not produce any symptom.

ECU ground (Analogue)

- If the circuit has an open, engine hard starting and rough idle will be caused and Service Code Nos. 09, 11, 12, 13, 20 and 23 will be output.

Main relay (Battery power)

- If the circuit is shorted, the EGI INJ fuse (30A) will burn out.

Room fuse (ECU memory power)

- If the circuit is open, the ECU memory function will not operate, and service codes for intermittent malfunctions will not be indicated. Also, the learning control will be canceled, but will not produce any particular symptom.
- If the circuit is shorted, the ROOM fuse (15A) will burn out.

[Input Device]**A/C switch**

- The switch monitor function can confirm the presence of an open or short circuit.
- If the circuit is open, the air conditioner (the magnetic clutch) will not operate.
- If the circuit is shorted, the air conditioner will constantly operate when the blower is ON.

Atmospheric pressure sensor

- The sensor is contained in the ECU.
- If the sensor has an open or short circuit, Service Code No. 14 is output, and the ECU will use a preprogrammed pressure of sea level.
- A malfunction in the sensor causes engine roughness at high elevation.

Clutch switch (MT)

☞ Refer to "Neutral / clutch switches" on page F-187.

Crank angle sensor (NE, G signal)

- If the NE signal circuit has an open or short, Service Code No. 02 is output.
- If the G signal circuit has an open or short, Service Code No. 03 is output.
- If the NE or G signal circuit has an open or short, the engine will not start (No fuel injection and no ignition).

Daytime running light unit (Canada)

- If the circuit has an open, the idle speed will be slightly slow.
- If the circuit is shorted, idle speed will be slightly fast.

E/L unit

- If the circuit has an open, the switch monitor function can confirm that the blower fan, headlight, rear window defroster, and electric cooling fan operating signals are not input to the ECU.
- If the circuit is short, the Idle speed will be increased slightly.

EGR Switch (Calif.)

- If the EGR switch or circuit has an open or short, Service Code No. 16 is output.
- In the above conditions, the EGR control valve will be fully closed.

Fuel thermosensor

- If the thermosensor circuit has an open or short, Service Code No. 23 is output.
- In the above conditions, the ECU will use a preprogrammed temperature value of 50°C {122°F} and no symptom will be noticed.

Heat hazard switch

- If the circuit has open, no symptom will be noticed.
- If the switch or circuit has a short, the heat hazard warning light will illuminate and the air pump will not operate, causing rough idle.

Inhibitor signal (AT ; Refer to Section K)

- If the circuit is open or shorted, the idle speed will be slightly low in R, D, S, and L ranges.

Intake air thermosensor

- If the thermosensor or circuit has an open or short, Service code No. 11 is output.
- In the above conditions, no symptom will be noticed.

Knock sensor

- If the knock sensor or circuit has an open or short, Service Code No. 05 is output.
- In the above conditions, ignition timing is retarded.

Metering oil pump position sensor

- If the sensor or circuit has an open or short, Service Code 20 is output.
- In the above conditions, the fuel injection amount is fixed, causing poor acceleration and hesitation.

Mileage switch / Power steering pressure switch

- If the switch circuit has an open circuit, no particular symptom will be noticed.
- If the switch circuit has a short circuit, idle speed will be increased.

Neutral switches (MT)

- The switch monitor function of the Self-Diagnosis Checker can confirm the presence of an open or short circuit.
- If the circuit is open, the idle speed drops when the A/C, P/S, or electrical load is ON.

1-2 switch (MT)

- If the circuit has an open or short, no symptom will be noticed.

Oxygen sensor

- If the sensor output voltage continues below 0.55V for 100 sec. after the engine exceeds 1,500 rpm because of an open or short circuit, Service Code No. 15 is output.
- If the sensor output voltage continues unchanged 50 sec. after the engine exceeds 1,500 rpm, Service Code No. 17 is output.
- In the above conditions, no fuel injection feedback control will be present and no symptom will be noticed.

Pressure sensor

- If the sensor or circuit has an open or short, Service code No. 13 is output.
- In the above condition, the ECU uses a preprogrammed fuel injection amount, causing rough idle and poor acceleration with afterburn.

P/S pressure switch

- Refer to "Mileage switch"

F

SERVICE POINTS

Reduce torque signal (AT ; Refer to Section K)

- If a malfunction occurs in the reduce torque signal, the torque reduction control system is inhibited and line pressure will be high at shifting. Shift shock may be slightly increased.

Slip lock-up signal (AT ; Refer to Section K)

- If a malfunction occurs in the slip lock-up signal, line pressure will be high at shifting and shift shock may be slightly increased.

Solenoid valve (Shift A) (AT)

- Refer to Section K

Solenoid valve (Shift B) (AT)

- Refer to Section K

Speedometer sensor

- If the vehicle speed signal circuit has an open or short, Service Code No. 06 is output.
- If the circuit has open or short, hold mode will not operate.

Start signal

- A lack of engine cranking signal will cause hard starting when engine is cold.

Stoplight switch

- The switch monitor function can confirm the presence of an open or short circuit.
- An open or short circuit will produce no symptom.
- A short circuit will cause the STOP fuse (20A) burn out.

Throttle sensor (Narrow range)

- If the sensor or circuit has an open or short, Service Code No. 18 is output.
- In the above condition, rough idle, and engine stall on deceleration will be caused.

Throttle sensor (Full range)

- If the sensor or circuit has an open or short, Service Code No. 12 is output.
- In the above condition, poor acceleration will be caused.

TEN terminal (Diagnosis connector)

- If the circuit is open, the Self-Diagnosis Checker or DT-S1000 can not perform service code checks, switch monitoring checks, real time monitor check and simulation check.
- If the circuit is shorted, the opening amount of the solenoid valve (ISC) will not change, causing hard starting and rough idle. The Self-Diagnosis Checker or DT-S1000 cannot perform sensor monitoring checks.

Water thermosensor

- If the thermosensor or circuit has an open or short, Service Code No. 09 is output, and ECU uses a preprogrammed temperature value of 82°C {180°F}.
- A malfunction in the water thermosensor or its circuit will cause hard starting or engine stall when engine is cold.
- In the above condition, the electric cooling fan will constantly operate when the ignition switch is ON.

[Output Device]**A/C relay**

- If the circuit is open, the air conditioner (Magnetic clutch) will not operate.
- If the circuit is shorted, the air conditioner will constantly operate when blower is ON, causing rough idle.

Air pump relay

- If the relay or circuit has an open or short, Service Code No. 54 is output.
- If the circuit is short, air pump will always operate, causing catalytic converter melted.
- If the circuit is open, the air pump will never operate, causing rough idle.

Circuit opening relay

- If the circuit is open, the engine will not start.
- If the circuit is shorted, the fuel pump will operate whenever the ignition switch is ON.

EC-AT control unit (AT)

- Refer to Section K

Electric cooling fan relay

- If the circuit is shorted, the cooling fan will always operate while the ignition switch ON.
- If the circuit is open, the cooling fan will not operate until the engine temperature exceeds 108°C {226°F}.

Fuel injector

- If a secondary injector or circuit has an open or short, Service Code No. 71 (Front) or 73 (Rear) is output, causing poor acceleration and lack of engine power.
- If a primary injector or circuit has an open, engine will stall and will not start.

Fuel pump relay

- If the relay or circuit has an open or short, Service Code No. 51 is output.
- If the circuit is open, engine will hesitate or engine power will lack.

FEN terminal (Diagnosis connector)

- If the circuit between the diagnosis connector and E/L unit is open, the Self-Diagnosis Checker buzzer will not sound during the service code check or the DT-S 1000 will indicate "System error" on the display.
- If the circuit between ECU 1F terminal and E/L unit is open, the Self-Diagnosis Checker buzzer will constantly sound during the service code check or the DT-S1000 will indicate "System error" on the display.
- If the circuit is shorted, code "88" will keep flashing and the buzzer will continue sounding (Self-Diagnosis Checker), or "service error" is indicated on DT-S1000 display, preventing a service code check.

Igniter

- If a trailing igniter or circuit has an open or short, idle speed will be slightly decreased and poor acceleration will be caused.
- If the leading igniter or circuit has an open or short, hard starting and rough idle will be caused.

Metering oil pump

- If the pump or circuit has an open or short, Service Code No. 26 and 27 are output.
- In the above conditions, ECU fixes ignition timing and fuel injection amount, causing engine poor acceleration.

F

SERVICE POINTS

MEN Terminal (Diagnosis Connector)

- If the circuit is open, the monitor lamp will not illuminate.
- If the circuit is shorted, the monitor lamp will stay on.

Solenoid valve (Accelerated warm-up system)

- If the solenoid valve or circuit has an open or short, Service Code No. 38 is output.
- If the circuit is open, the fast idle speed just after engine starting will not exceed 2,000 rpm.
- If the circuit is shorted, the idle speed will be increased and then hunted at the specified speed (approx. 1500 rpm after warm-up).

Solenoid valve (Charge control)

- If the solenoid valve or circuit has an open or short, Service Code No. 45 is output.
- In the above conditions, the ECU fixes the ignition timing and fuel injection amount, causing poor acceleration and lack of power.

Solenoid valve (Charge relief)

- If the solenoid valve or circuit has an open or short, Service Code No. 46 is output.
- If the circuit is open, the charge relief valve will always open, causing poor acceleration.
- If the circuit is shorted, the charge relief valve will always closed, causing momentarily intake air noise on acceleration.

Solenoid valve (Double throttle control)

- If the solenoid valve or circuit has an open or short, Service Code No. 50 is output.
- If the circuit is open, the double throttle valve will always closed, causing poor acceleration and lack of power.
- If the circuit is shorted, the double throttle valve will always open, causing hesitation when the engine is cold.

Solenoid valve (EGR)

- If the solenoid valve or circuit has an open or short, Service Code No. 28 is output.
- If the circuit is open, no symptom will be noticed.
- If the circuit is shorted, the EGR valve will always open, causing engine stalling and hard starting.

Solenoid valve (ISC)

- If the solenoid valve or circuit has an open or short, Service Code No. 34 is output.
- If the circuit is open, the valve will always fully closed, causing rough idle and hard starting.
- If the circuit is shorted, the valve will always fully open, causing high idle speed. (After warm-up, engine hunts at approx. 1500 rpm.)

Solenoid valve (Port air bypass)

- If the solenoid valve or circuit has an open or short, Service Code No. 33 is output.
- In the above conditions, no symptom will be noticed.

Solenoid valve (Pressure regulator control)

- If the solenoid valve or circuit has an open or short, Service Code No. 25 is output.
- If the circuit is open, hard starting may result when the engine is hot.
- If the circuit is shorted, fuel pressure will always be approx. 280 kPa (2.9 kg/cm², 41 psi) and no symptom will be noticed.

Solenoid valve (Purge control)

- If the solenoid valve or circuit has an open or short, Service Code No. 40 is output.
- If the circuit is open, no symptom will be noticed.
- If the circuit is shorted, the engine stalls at low speed.

Solenoid valve (Relief 1)

- If the solenoid valve or circuit has an open or short, Service Code No. 31 is output.
- If the circuit is open, no symptom will be noticed.
- If the circuit is shorted, solenoid / valve will be always open and CO and HC will be increased.

Solenoid valve (Relief 2)

- If the solenoid valve or circuit has an open or short, Service Code No. 39 is output.
- If the circuit is open, no symptom will be noticed.
- If the circuit is shorted, secondary air noise will be heard while the air pump operates.

Solenoid valve (Split air bypass)

- If the solenoid valve or circuit has an open or short, Service Code No. 30 is output
- In the above conditions, no symptom will be produced.

Solenoid valve (switching)

- If the solenoid valve or circuit has an open or short, Service Code No. 32 is output.
- If the circuit is open, no symptom will be noticed.
- If the circuit is shorted, rough idle will result.

Solenoid valve (Turbo control 1, Turbo control 2)

- If the solenoid valve or circuit has an open or short, Service Code No. 44 is output.
- If the circuit is open, the turbo control valve will not open, causing poor acceleration and lack of power.
- If the circuit is shorted, turbo control valve will open earlier on acceleration, causing poor acceleration.

Solenoid valve (Turbo precontrol)

- If the solenoid valve or circuit has an open or short, Service Code No. 42 is output.
- If the circuit is open, the precontrol valve will open earlier, causing slightly hesitation and poor acceleration.
- If the circuit is short, precontrol valve will never open, causing hesitation and poor acceleration.

Solenoid valve (Wastegate control)

- If the solenoid valve or circuit has an open or short, Service Code No. 43 is output.
- If the circuit is open, wastegate valve will open earlier, causing poor acceleration and lack of power.
- If the circuit is shorted, wastegate valve will not open easily and no symptom will be noticed. (To prevent engine damage, the overboost fuel cut will be operated)

B-1b ENGINE CONTROL SYSTEM ■ FUEL CONTROL SYSTEM

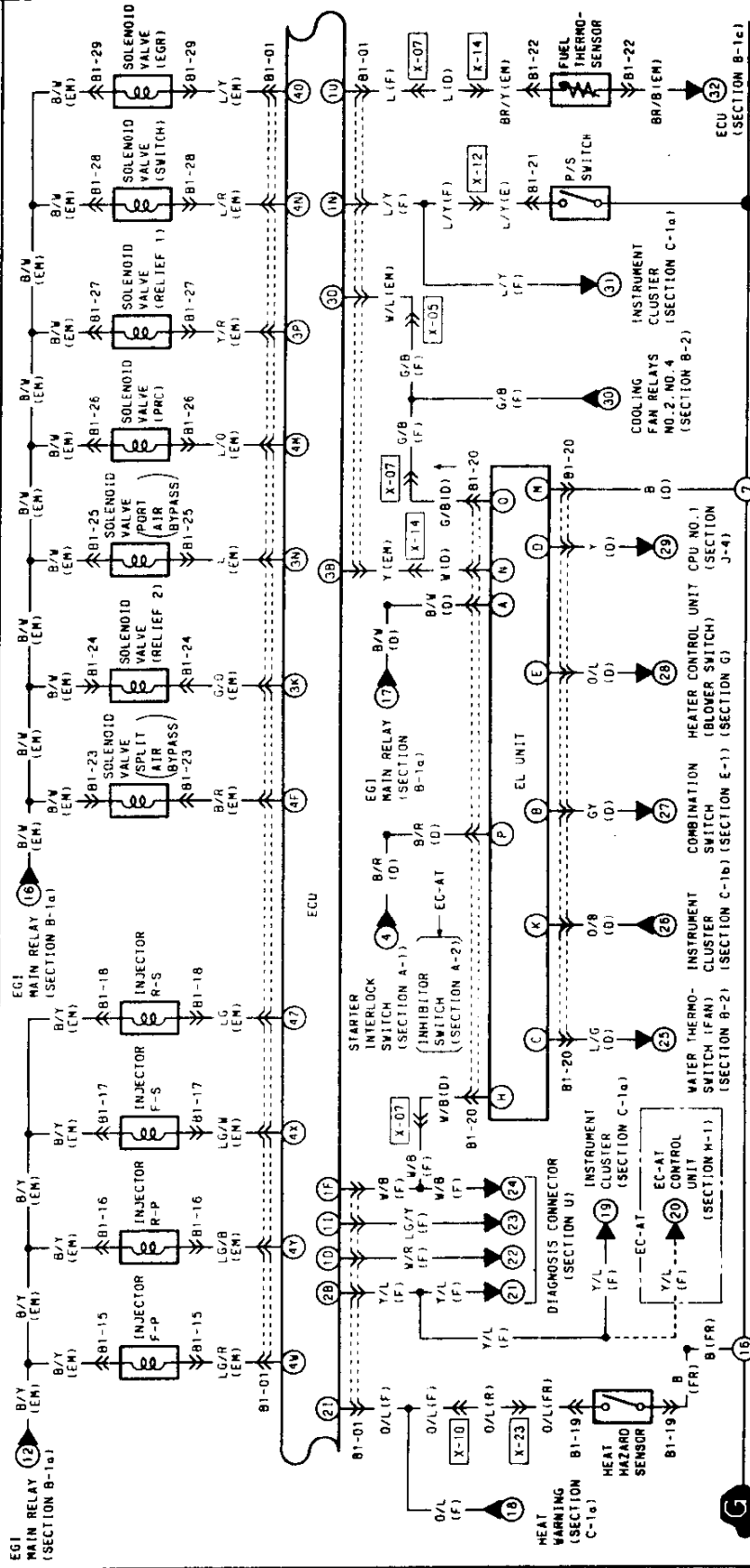

B1-01 ECU	1U 1S 10 1M 1K 1I 1G 1E 1A 1B 1C 1D 1E 1F 1G 1H 1J 1K 1L 1M 1N 1P 1Q 1R 1S 1T 1U 1V 1W 1X 1Y 1Z	2A 2B 2C 2D 2E 2F 2G 2H 2J 2K 2L 2M 2N 2P 2Q 2R 2S 2T 2U 2V 2W 2X 2Y 2Z	3A 3B 3C 3D 3E 3F 3G 3H 3J 3K 3L 3M 3N 3P 3Q 3R 3S 3T 3U 3V 3W 3X 3Y 3Z	4A 4B 4C 4D 4E 4F 4G 4H 4J 4K 4L 4M 4N 4P 4Q 4R 4S 4T 4U 4V 4W 4X 4Y 4Z	5A 5B 5C 5D 5E 5F 5G 5H 5J 5K 5L 5M 5N 5P 5Q 5R 5S 5T 5U 5V 5W 5X 5Y 5Z	6A 6B 6C 6D 6E 6F 6G 6H 6J 6K 6L 6M 6N 6P 6Q 6R 6S 6T 6U 6V 6W 6X 6Y 6Z	7A 7B 7C 7D 7E 7F 7G 7H 7J 7K 7L 7M 7N 7P 7Q 7R 7S 7T 7U 7V 7W 7X 7Y 7Z	8A 8B 8C 8D 8E 8F 8G 8H 8J 8K 8L 8M 8N 8P 8Q 8R 8S 8T 8U 8V 8W 8X 8Y 8Z	9A 9B 9C 9D 9E 9F 9G 9H 9J 9K 9L 9M 9N 9P 9Q 9R 9S 9T 9U 9V 9W 9X 9Y 9Z	10A 10B 10C 10D 10E 10F 10G 10H 10J 10K 10L 10M 10N 10P 10Q 10R 10S 10T 10U 10V 10W 10X 10Y 10Z	11A 11B 11C 11D 11E 11F 11G 11H 11J 11K 11L 11M 11N 11P 11Q 11R 11S 11T 11U 11V 11W 11X 11Y 11Z	12A 12B 12C 12D 12E 12F 12G 12H 12J 12K 12L 12M 12N 12P 12Q 12R 12S 12T 12U 12V 12W 12X 12Y 12Z	13A 13B 13C 13D 13E 13F 13G 13H 13J 13K 13L 13M 13N 13P 13Q 13R 13S 13T 13U 13V 13W 13X 13Y 13Z	14A 14B 14C 14D 14E 14F 14G 14H 14J 14K 14L 14M 14N 14P 14Q 14R 14S 14T 14U 14V 14W 14X 14Y 14Z	15A 15B 15C 15D 15E 15F 15G 15H 15J 15K 15L 15M 15N 15P 15Q 15R 15S 15T 15U 15V 15W 15X 15Y 15Z	16A 16B 16C 16D 16E 16F 16G 16H 16J 16K 16L 16M 16N 16P 16Q 16R 16S 16T 16U 16V 16W 16X 16Y 16Z	17A 17B 17C 17D 17E 17F 17G 17H 17J 17K 17L 17M 17N 17P 17Q 17R 17S 17T 17U 17V 17W 17X 17Y 17Z	18A 18B 18C 18D 18E 18F 18G 18H 18J 18K 18L 18M 18N 18P 18Q 18R 18S 18T 18U 18V 18W 18X 18Y 18Z	19A 19B 19C 19D 19E 19F 19G 19H 19J 19K 19L 19M 19N 19P 19Q 19R 19S 19T 19U 19V 19W 19X 19Y 19Z	20A 20B 20C 20D 20E 20F 20G 20H 20J 20K 20L 20M 20N 20P 20Q 20R 20S 20T 20U 20V 20W 20X 20Y 20Z	21A 21B 21C 21D 21E 21F 21G 21H 21J 21K 21L 21M 21N 21P 21Q 21R 21S 21T 21U 21V 21W 21X 21Y 21Z	22A 22B 22C 22D 22E 22F 22G 22H 22J 22K 22L 22M 22N 22P 22Q 22R 22S 22T 22U 22V 22W 22X 22Y 22Z	23A 23B 23C 23D 23E 23F 23G 23H 23J 23K 23L 23M 23N 23P 23Q 23R 23S 23T 23U 23V 23W 23X 23Y 23Z	24A 24B 24C 24D 24E 24F 24G 24H 24J 24K 24L 24M 24N 24P 24Q 24R 24S 24T 24U 24V 24W 24X 24Y 24Z	25A 25B 25C 25D 25E 25F 25G 25H 25J 25K 25L 25M 25N 25P 25Q 25R 25S 25T 25U 25V 25W 25X 25Y 25Z	26A 26B 26C 26D 26E 26F 26G 26H 26J 26K 26L 26M 26N 26P 26Q 26R 26S 26T 26U 26V 26W 26X 26Y 26Z	27A 27B 27C 27D 27E 27F 27G 27H 27J 27K 27L 27M 27N 27P 27Q 27R 27S 27T 27U 27V 27W 27X 27Y 27Z	28A 28B 28C 28D 28E 28F 28G 28H 28J 28K 28L 28M 28N 28P 28Q 28R 28S 28T 28U 28V 28W 28X 28Y 28Z	29A 29B 29C 29D 29E 29F 29G 29H 29J 29K 29L 29M 29N 29P 29Q 29R 29S 29T 29U 29V 29W 29X 29Y 29Z	30A 30B 30C 30D 30E 30F 30G 30H 30J 30K 30L 30M 30N 30P 30Q 30R 30S 30T 30U 30V 30W 30X 30Y 30Z	31A 31B 31C 31D 31E 31F 31G 31H 31J 31K 31L 31M 31N 31P 31Q 31R 31S 31T 31U 31V 31W 31X 31Y 31Z	32A 32B 32C 32D 32E 32F 32G 32H 32J 32K 32L 32M 32N 32P 32Q 32R 32S 32T 32U 32V 32W 32X 32Y 32Z	33A 33B 33C 33D 33E 33F 33G 33H 33J 33K 33L 33M 33N 33P 33Q 33R 33S 33T 33U 33V 33W 33X 33Y 33Z	34A 34B 34C 34D 34E 34F 34G 34H 34J 34K 34L 34M 34N 34P 34Q 34R 34S 34T 34U 34V 34W 34X 34Y 34Z	35A 35B 35C 35D 35E 35F 35G 35H 35J 35K 35L 35M 35N 35P 35Q 35R 35S 35T 35U 35V 35W 35X 35Y 35Z	36A 36B 36C 36D 36E 36F 36G 36H 36J 36K 36L 36M 36N 36P 36Q 36R 36S 36T 36U 36V 36W 36X 36Y 36Z	37A 37B 37C 37D 37E 37F 37G 37H 37J 37K 37L 37M 37N 37P 37Q 37R 37S 37T 37U 37V 37W 37X 37Y 37Z	38A 38B 38C 38D 38E 38F 38G 38H 38J 38K 38L 38M 38N 38P 38Q 38R 38S 38T 38U 38V 38W 38X 38Y 38Z	39A 39B 39C 39D 39E 39F 39G 39H 39J 39K 39L 39M 39N 39P 39Q 39R 39S 39T 39U 39V 39W 39X 39Y 39Z	40A 40B 40C 40D 40E 40F 40G 40H 40J 40K 40L 40M 40N 40P 40Q 40R 40S 40T 40U 40V 40W 40X 40Y 40Z	41A 41B 41C 41D 41E 41F 41G 41H 41J 41K 41L 41M 41N 41P 41Q 41R 41S 41T 41U 41V 41W 41X 41Y 41Z	42A 42B 42C 42D 42E 42F 42G 42H 42J 42K 42L 42M 42N 42P 42Q 42R 42S 42T 42U 42V 42W 42X 42Y 42Z	43A 43B 43C 43D 43E 43F 43G 43H 43J 43K 43L 43M 43N 43P 43Q 43R 43S 43T 43U 43V 43W 43X 43Y 43Z	44A 44B 44C 44D 44E 44F 44G 44H 44J 44K 44L 44M 44N 44P 44Q 44R 44S 44T 44U 44V 44W 44X 44Y 44Z	45A 45B 45C 45D 45E 45F 45G 45H 45J 45K 45L 45M 45N 45P 45Q 45R 45S 45T 45U 45V 45W 45X 45Y 45Z	46A 46B 46C 46D 46E 46F 46G 46H 46J 46K 46L 46M 46N 46P 46Q 46R 46S 46T 46U 46V 46W 46X 46Y 46Z	47A 47B 47C 47D 47E 47F 47G 47H 47J 47K 47L 47M 47N 47P 47Q 47R 47S 47T 47U 47V 47W 47X 47Y 47Z	48A 48B 48C 48D 48E 48F 48G 48H 48J 48K 48L 48M 48N 48P 48Q 48R 48S 48T 48U 48V 48W 48X 48Y 48Z	49A 49B 49C 49D 49E 49F 49G 49H 49J 49K 49L 49M 49N 49P 49Q 49R 49S 49T 49U 49V 49W 49X 49Y 49Z	50A 50B 50C 50D 50E 50F 50G 50H 50J 50K 50L 50M 50N 50P 50Q 50R 50S 50T 50U 50V 50W 50X 50Y 50Z
-----------	---	---	---	---	---	---	---	---	---	---	---	---	---	---	---	---	---	---	---	---	---	---	---	---	---	---	---	---	---	---	---	---	---	---	---	---	---	---	---	---	---	---	---	---	---	---	---	---	---	---

F

SERVICE POINTS

ELECTRICAL DIAGNOSIS SUPPORT

[Power and Ground]

Main relay (Battery power)

Circuit	Condition		
	Open circuit	Short circuit	Poor ground
ECU (1B)—Main relay	Engine hard starting	EGL INJ fuse (30A) burns out when ignition switch ON	NA

16E0F1-291

Room fuse (Memory power)

Circuit	Condition		
	Open circuit	Short circuit	Poor ground
ECU (1A)—Room fuse	No symptom	ROOM fuse (15A) burns out	NA

16E0F1-292

ECU ground (Output device, Injector, System, Analogue)

Circuit	Condition		
	Open circuit	Short circuit	Poor ground
ECU (4A)—Ground (Output device)	(One side open circuit) No symptom	NA	(One side poor ground) No symptom
ECU (4B)—Ground (Injector)	(Both sides open circuit) Engine will not start		(Both sides poor ground) Engine will not start
ECU (4C)—Ground (System)	No symptom		No symptom
ECU (4D)—Ground (Analogue)	Code Nos. 09, 11, 12, 13, 20, and 23 Engine hard starting Rough idle		Code Nos. 09, 11, 12, 13, 20, and 23 Engine hard starting Rough idle

16E0F2-293

[Input Device]

A/C switch

Circuit	Condition		
	Open circuit	Short circuit	Poor ground
ECU (1E)—A/C amplifier	Air conditioner (magnetic clutch) will not operate	Air conditioner will constantly operate with blower ON	NA

Clutch switch (MT)

Circuit	Condition		
	Open circuit	Short circuit	Poor ground
ECU (1Q)—Clutch switch	No symptom	No symptom	NA

Crank angle sensor (NE, G signal)

Circuit	Condition		
	Open circuit	Short circuit	Poor ground
ECU (4E)—Crank angle sensor (NE)	Code No. 02 output Engine will not start	Code No. 02 output Engine will not start	NA
ECU (4G)—Crank angle sensor (G)	Code No. 03 output Engine will not start	Code No. 03 output Engine will not start	
ECU (4H)—Crank angle sensor (Ground)	Code Nos. 02 and 03 output Engine will not start	NA	Engine will not start Engine suddenly stalls

Daytime running light unit (Canada)

Circuit	Condition		
	Open circuit	Short circuit	Poor ground
ECU (3J)—Daytime running light unit	Idle speed may be slightly low	Idle speed may be slightly high	NA

NA: Not applicable

SERVICE POINTS

F

E/L unit

Circuit	Condition		
	Open circuit	Short circuit	Poor ground
ECU (1F)—E/L unit (H)	MIL will never ON	MIL will always ON Self-Diagnosis Checker buzzer sounds constantly	NA
ECU (3B)—E/L unit (N)	Idle speed will be low when E/L ON* ¹	Idle speed will be high	
Main relay—E/L unit (A)	Idle speed will be low when E/L ON* ¹	EGI INJ fuse (30A) burns out when ignition switch ON	
Headlight switch—E/L unit (B)	Idle speed may be low when headlight switch ON	Parking lights will always ON	
Electric cooling fan relay—E/L unit (C)	Idle speed may be low when cooling fan operates	Cooling fan always oper- ates when ignition switch ON	
Rear defroster switch—E/L unit (D)	Idle speed may be low when defroster switch ON	Rear window defroster always ON when ignition switch ON	
Heater control unit—E/L unit (E)	Idle speed may be low when blower fan operate high speed	High idle speed when blower fan not operate	
MIL—E/L unit (K)	MIL will never ON	MIL will always ON	Idle speed hunts or drops when E/L ON* ¹ MIL will never ON
Ground—E/L unit (M)	Idle speed drops when E/L ON* ¹ MIL will never ON	NA	
Electric cooling fan relay— E/L unit (O)	Idle speed may be low when cooling fan operates	Cooling fan always oper- ates when ignition switch ON	NA
Inhibitor switch—E/L unit (P)	No symptom	No symptom	

* E/L ON: Headlight switch ON, electric cooling fan operating, rear window defroster switch ON, or blower fan control switch at 3rd or 4th position.

EGR switch (Calif.)

Circuit	Condition		
	Open circuit	Short circuit	Poor ground
ECU (3J)—EGR switch	Code No. 16 output No symptom	Code No. 16 output No symptom	NA
ECU (4D)—EGR switch		No symptom	

Fuel thermosensor

Circuit	Condition		
	Open circuit	Short circuit	Poor ground
ECU (1U)—Fuel thermosensor	Code No. 23 output No symptom	Code No. 23 output No symptom	NA
ECU (4D)—Fuel thermosensor		No symptom	

Heat hazard switch

Circuit	Condition		
	Open circuit	Short circuit	Poor ground
ECU (2I)—Heat hazard switch	No symptom	Heat hazard warning light illuminates Rough idle	NA
Ground—Heat hazard switch		No symptom	No symptom

NA: Not applicable

F

SERVICE POINTS

Inhibitor signal (AT)

Circuit	Condition		
	Open circuit	Short circuit	Poor ground
ECU (1R)—EC-AT control unit (1C)	Idle speed drops when shifted to L, S, D or R range		NA

Intake air thermosensor

Circuit	Condition		
	Open circuit	Short circuit	Poor ground
ECU (3L)—Thermosensor	Code No. 11 output No symptom	Code No. 11 output No symptom	NA
ECU (4D)—Thermosensor		No symptom	

Knock sensor

Circuit	Condition		
	Open circuit	Short circuit	Poor ground
ECU (3M)—Knock sensor	Code No. 05 output Lack of power Knocking	Code No. 05 output Lack of power Knocking	NA

Metering oil pump position sensor

Circuit	Condition		
	Open circuit	Short circuit	Poor ground
ECU (3A)—Metering oil pump (J)	Code No. 20 output Poor acceleration Hesitation	Code No. 20 output Poor acceleration Hesitation	NA
ECU (4D)—Metering oil pump (H)		No symptom	
ECU (3I)—Metering oil pump (I)		Code No. 20 output Poor acceleration Hesitation	

Mileage switch

Circuit	Condition		
	Open circuit	Short circuit	Poor ground
ECU (1N)—Mileage switch	No symptom	Idle speed slightly high	NA

Neutral switch (MT)

Circuit	Condition		
	Open circuit	Short circuit	Poor ground
ECU (1R)—Neutral switch	Idle speed slightly high	Idle speed drops when A/C, P/S, or E/L ON	NA

1-2 switch (MT)

Circuit	Condition		
	Open circuit	Short circuit	Poor ground
ECU (2K)—1-2 switch	No symptom	No symptom	NA
ECU (2L)—1-2 switch			
Ground—1-2 switch			No symptom

NA: Not applicable

SERVICE POINTS

F

Oxygen sensor

Circuit	Condition		
	Open circuit	Short circuit	Poor ground
ECU (3C)—Oxygen sensor	Code No. 15 output No symptom	Code No. 15 output No symptom	NA

Pressure sensor

Circuit	Condition		
	Open circuit	Short circuit	Poor ground
ECU (10)—Pressure sensor	Code No. 13 output Poor acceleration Rough idle	Code No. 13 output	NA
ECU (3I)—Pressure sensor		Poor acceleration	
ECU (4D)—Pressure sensor		Rough idle No symptom	

P/S Pressure sensor

Circuit	Condition		
	Open circuit	Short circuit	Poor ground
ECU (1N)—P/S Pressure switch	No symptom	Idle speed slightly high	NA

Reduced torque signal, slip lock-up signal (AT)

Circuit	Condition		
	Open circuit	Short circuit	Poor ground
ECU (1Q)—EC-AT control unit (2P)	Shift shock slightly increased		NA

Solenoid valve (Shift A) (AT)

Circuit	Condition		
	Open circuit	Short circuit	Poor ground
ECU (2K)—EC-AT CU (1D)	Shift shock slightly increased		NA

Solenoid valve (Shift B) (AT)

Circuit	Condition		
	Open circuit	Short circuit	Poor ground
ECU (2L)—EC-AT CU (1B)	Shift shock slightly increased		NA

Speedometer sensor

Circuit	Condition		
	Open circuit	Short circuit	Poor ground
ECU (1M)—Speedometer sensor	Code No. 06 output Hold mode will not operate (AT)		NA

Stoplight signal (Stoplight switch)

Circuit	Condition		
	Open circuit	Short circuit	Poor ground
ECU (1S)—Stoplight switch	No symptom	STOP fuse (20A) burns out	NA

NA: Not applicable

F

SERVICE POINTS

Throttle sensor (Narrow range, Full range)

Circuit	Condition		
	Open circuit	Short circuit	Poor ground
ECU (3F)—Throttle sensor (Narrow range)	Code No.18 output Rough idle Strong shift shock (AT)	Code No.18 output Rough idle Strong shift shock (AT)	NA
ECU (3G)—Throttle sensor (Full range)	Code No.12 output Poor acceleration Strong shift shock (AT)	Code No.12 output Poor acceleration Strong shift shock (AT)	
ECU (3I)—Throttle sensor	Code Nos 12, 18 output Rough idle	Code Nos.12 and 18 output Rough idle	
ECU (4D)—Throttle sensor	Code No.12 output Rough idle	No symptom	

TEN terminal (Diagnosis connector)

Circuit	Condition		
	Open circuit	Short circuit	Poor ground
ECU (1I)—Diagnosis connector	Cannot perform service code checks and switch monitor checks	Hard starting Rough idle	NA

16E0F2-'84

Water thermosensor

Circuit	Condition		
	Open circuit	Short circuit	Poor ground
ECU (3E)—Water thermosensor	Code No.09 output Rough idle and hard starting when engine cold	Code No.09 output Rough idle and hard starting when engine cold	NA
ECU (4D)—Water thermosensor		No symptom	

[Output Device]

A/C relay

Circuit	Condition		
	Open circuit	Short circuit	Poor ground
ECU (1L)—A/C relay	A/C will not operate	A/C constantly operate when blower ON Rough idle	NA

Air pump relay

Circuit	Condition		
	Open circuit	Short circuit	Poor ground
ECU (2J)—Air pump relay	Code No.54 output Rough idle	Code No.54 output Catalytic converter melted	NA

Fuel injector

Circuit	Condition		
	Open circuit	Short circuit	Poor ground
ECU (4X, 4Z)—Secondary injector	Code No.71 or 73 output Lack of power	Code No.71 or 73 output Engine will not start	NA
ECU (4W, 4X)—Primary injector		Engine stalls Engine will not start	

Electric cooling fan relay

Circuit	Condition		
	Open circuit	Short circuit	Poor ground
ECU (3D)—fan relay	Cooling fan will not operate until coolant temperature exceeds 108°C {226°F}	Cooling fan always operate when ignition switch ON	NA

NA : Not applicable

SERVICE POINTS

F

Fuel pump relay

Circuit	Condition		
	Open circuit	Short circuit	Poor ground
ECU (1K)—Fuel pump relay	Code No.51 output Hesitation Lack of power	Code No.51 output No symptom	NA

FEN terminal (Diagnosis connector)

Circuit	Condition		
	Open circuit	Short circuit	Poor ground
ECU (1F)—Diagnosis connector	Self-Diagnosis Checker buzzer will not sound during service code check or "system error" indicated on DT-S1000 display	Code "88" will keep flashing and buzzer will continue sounding during service code check or "system error" indicated on DT-S1000 display	NA

Igniter

Circuit	Condition		
	Open circuit	Short circuit	Poor ground
ECU (1G)—Igniter (Trailing Front) ECU (1J)—Igniter (Trailing Rear)	Poor acceleration Hard starting when engine cold		NA
ECU (1H)—Igniter (Leading)	Rough idle Poor acceleration Hard starting when engine cold		

Metering oil pump

Circuit	Condition		
	Open circuit	Short circuit	Poor ground
ECU (4I, 4J, 4K, 4L)—Metering oil pump	Code No.26 and 27 output Poor acceleration		NA

NA: Not applicable

16E0F2-320

MEN terminal (Diagnosis connector)

Circuit	Condition		
	Open circuit	Short circuit	Poor ground
ECU (1D)—MEN terminal	Monitor lamp will not illuminate	Monitor lamp stays on	NA

Solenoid valve (Accelerated warm-up system)

Circuit	Condition		
	Open circuit	Short circuit	Poor ground
ECU (4P)—Solenoid valve	Code No.38 output Fast idle speed just after engine starting will not exceed 2,000 rpm	Code No.38 output Idle speed stays stays or fluctuates at approx. 1,500 rpm after warm-up	NA
Solenoid valve—Main relay		EGI INJ fuse (30A) burns out when ignition switch ON	

16E0F2-327

Solenoid valve (Charge control)

Circuit	Condition		
	Open circuit	Short circuit	Poor ground
ECU (4T)—Solenoid valve	Code No.45 output Lack of power Poor acceleration	Code No.45 output Lack of power Poor acceleration	NA
Solenoid valve—Main relay		EGI INJ fuse (30A) burns out when ignition switch ON	

NA: Not applicable

F

SERVICE POINTS

Solenoid valve (Charge relief)

Circuit	Condition		
	Open circuit	Short circuit	Poor ground
ECU (4S)—Solenoid valve	Code No.46 output Poor acceleration	Code No.46 output Momentarily Intake air noise on acceleration	NA
Solenoid valve—Main relay		EGI INJ fuse (30A) burns out when ignition switch ON	

Solenoid valve (Double throttle control)

Circuit	Condition		
	Open circuit	Short circuit	Poor ground
ECU (3O)—Solenoid valve	Code No.50 output Poor acceleration Lack of power	Code No.50 output Hesitation when engine cold	NA
Solenoid valve—Main relay		EGI INJ fuse (30A) burns out when ignition switch ON	

Solenoid valve (EGR) [Calif.]

Circuit	Condition		
	Open circuit	Short circuit	Poor ground
ECU (4O)—Solenoid valve	Code No.28 output No symptom	Code No.28 output Engine stall Hard starting	NA
Solenoid valve—Main relay		EGI INJ fuse (30A) burns out when ignition switch ON	

Solenoid valve (ISC)

Circuit	Condition		
	Open circuit	Short circuit	Poor ground
ECU (4Q)—Solenoid valve	Code No.34 output Rough idle Hard start	Code No.34 output Idle speed stays or fluctu- ates at approx. 1,500 rpm after warm-up	NA
Solenoid valve—Main relay		EGI INJ fuse (30A) burns out when ignition switch ON	

Solenoid valve (Port air bypass)

Circuit	Condition		
	Open circuit	Short circuit	Poor ground
ECU (3N)—Solenoid valve	Code No.33 output No symptom	Code No.33 output No symptom	NA
Solenoid valve—Main relay		EGI INJ fuse (30A) burns out when ignition switch ON	

NA: Not applicable

Solenoid valve (Pressure regulator control)

Circuit	Condition		
	Open circuit	Short circuit	Poor ground
ECU (4M)—Solenoid valve	Code No.25 output Hard starting when engine warm-up	Code No.25 output No symptom	NA
Solenoid valve—Main relay		EGI INJ fuse (30A) burns out when ignition switch ON	

Solenoid valve (Purge control)

Circuit	Condition		
	Open circuit	Short circuit	Poor ground
ECU (3H)—Solenoid valve	Code No.40 output No symptom	Code No.40 output Hard starting Engine stalls at low speed	NA
Solenoid valve—Main relay		EGI INJ fuse (30A) burns out when ignition switch ON	

Solenoid valve (Relief 1)

Circuit	Condition		
	Open circuit	Short circuit	Poor ground
ECU (3P)—Solenoid valve	Code No.31 output No symptom	Code No.31 output CO and HC increased	NA
Solenoid valve—Main relay		EGI INJ fuse (30A) burns out when ignition switch ON	

Solenoid valve (Relief 2)

Circuit	Condition		
	Open circuit	Short circuit	Poor ground
ECU (3K)—Solenoid valve	Code No.39 output No symptom	Code No.39 output Secondary air noise heard while air pump operates	NA
Solenoid valve—Main relay		EGI INJ fuse (30A) burns out when ignition switch ON	

Solenoid valve (Split air bypass)

Circuit	Condition		
	Open circuit	Short circuit	Poor ground
ECU (4F)—Solenoid valve	Code No.30 output No symptom	Code No.30 output No symptom	NA
Solenoid valve—Main relay		EGI INJ fuse (30A) burns out when ignition switch ON	

Solenoid valve (Switching)

Circuit	Condition		
	Open circuit	Short circuit	Poor ground
ECU (4N)—Solenoid valve	Code No.32 output No symptom	Code No.32 output Rough idle	NA
Solenoid valve—Main relay		EGI INJ fuse (30A) burns out when ignition switch ON	

NA: Not applicable

F

SERVICE POINTS

Solenoid valve (Turbo control 1, Turbo control 2)

Circuit	Condition		
	Open circuit	Short circuit	Poor ground
ECU (4R)—Solenoid valve (s)	Code No.44 output Poor acceleration	Code No.44 output Poor acceleration	NA
Solenoid valve (s)—Main relay		EGI INJ fuse (30A) burns out when ignition switch ON	

Solenoid valve (Turbo precontrol)

Circuit	Condition		
	Open circuit	Short circuit	Poor ground
ECU (4V)—Solenoid valve	Code No.42 output Hesitation Poor acceleration	Code No.42 output Hesitation Poor acceleration	NA
Solenoid valve—Main relay		EGI INJ fuse (30A) burns out when ignition switch ON	

Solenoid valve (Wastegate control)

Circuit	Condition		
	Open circuit	Short circuit	Poor ground
ECU (4U)—Solenoid valve	Code No.43 output Lack of power Poor acceleration	Code No.43 output No symptom	NA
Solenoid valve—Main relay		EGI INJ fuse (30A) burns out when ignition switch ON	

NA: Not applicable