



This document is brought to you through the kind services of

Kevin Wright

krwright@wankel.net

<http://www.wankel.net/~krwright>

who, well, didn't do much this time, since Paul Lee provided the thing already scanned and compiled into a PDF! (Thanks!). Go visit his website: <http://www.iluvmyrx7.com/index.htm> Lots of RX-7 goodness there.

There are several ways to get around in the document. I have provided Bookmarks to all the sections, and thumbnails are also provided in the Thumbnails side bar.

I have also included a label for the spine of a binder, for those who wish to print out all the pages and keep a dead-tree edition handy.☺

The original document is © 1979 Toyo Kogyo Co., Ltd., and remains so. This version is provided as a service for owners of first generation Mazda RX-7s who are having a devil of a time locating the factory service manual for a reasonable price.

If you really want to send me money, email me and I'll tell you where to send it, but it's not necessary. Consider this payback for all the good advice and information gleaned from the various RX-7 email lists!

Subscribe to the Early Mazda Rotaries email list:

Send an email with "subscribe" (without the quotes) to list-request@sa22c.org

See <http://www.dfw-rx7.com> for information on the DFW-RX7 email list.

09/16/03

BRAKES

- 11-A. FRONT BRAKE 11 : 1
- 11-A-1. Removing Disc Brake Pads 11 : 1
- 11-A-2. Checking Disc Brake Pads 11 : 1
- 11-A-3. Installing Disc Brake Pads 11 : 1
- 11-A-4. Removing Caliper 11 : 2
- 11-A-5. Disassembling Caliper 11 : 2
- 11-A-6. Checking Caliper 11 : 3
- 11-A-7. Assembling Caliper 11 : 3
- 11-A-8. Installing Caliper 11 : 3
- 11-A-9. Checking Brake Disc 11 : 3
- 11-A-10. Replacing Brake Disc 11 : 3
- 11-B. REAR BRAKE 11 : 4
- 11-B-1. Removing Rear Brake Shoes 11 : 4
- 11-B-2. Inspecting Rear Brake 11 : 4
- 11-B-3. Installing Rear Brake Shoes 11 : 5
- 11-B-4. Removing and Disassembling Rear Wheel Cylinder 11 : 5
- 11-B-5. Checking Rear Wheel Cylinder 11 : 5
- 11-B-6. Assembling and Installing Rear Wheel Cylinder 11 : 5
- 11-B-7. Adjusting Rear Brake 11 : 6
- 11-C. BRAKE MASTER CYLINDER 11 : 6
- 11-C-1. Removing Brake Master Cylinder 11 : 6
- 11-C-2. Disassembling Brake Master Cylinder 11 : 6
- 11-C-3. Checking Brake Master Cylinder 11 : 7
- 11-C-4. Assembling Brake Master Cylinder 11 : 7
- 11-C-5. Installing Brake Master Cylinder 11 : 7
- 11-D. POWER BRAKE UNIT 11 : 8
- 11-D-1. Removing Power Brake Unit 11 : 8
- 11-D-2. Disassembling Power Brake Unit 11 : 8
- 11-D-3. Checking Power Brake Unit 11 : 9
- 11-D-4. Assembling Power Brake Unit 11 : 9
- 11-D-5. Installing Power Brake Unit 11 : 10
- 11-E. AIR BLEEDING 11 : 11
- 11-F. BRAKE PEDAL 11 : 11
- 11-F-1. Adjusting Brake Pedal Height 11 : 11
- 11-F-2. Adjusting Brake Pedal Free Travel 11 : 11
- 11-G. PARKING BRAKE ADJUSTMENT 11 : 12
- 11-H. BRAKE FLUID LEVEL SENSOR 11 : 12
- 11-H-1. Checking Brake Fluid Level Sensor 11 : 12
- 11-H-2. Replacing Brake Fluid Level Sensor 11 : 12
- 11-I. PROPORTIONING BYPASS VALVE 11 : 12
- 11-J. HYDRAULIC LINES INSPECTION 11 : 12

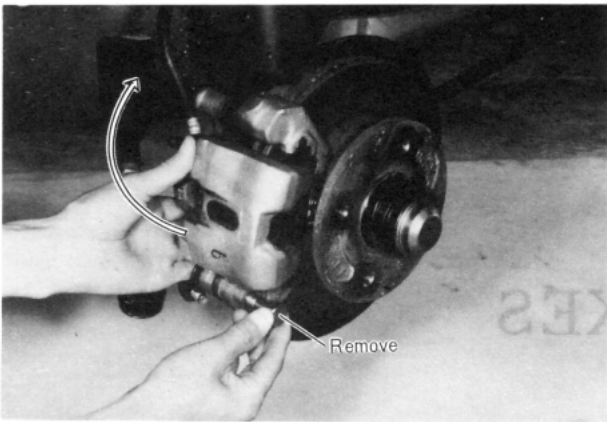

Fig. 11-1



Fig. 11-2

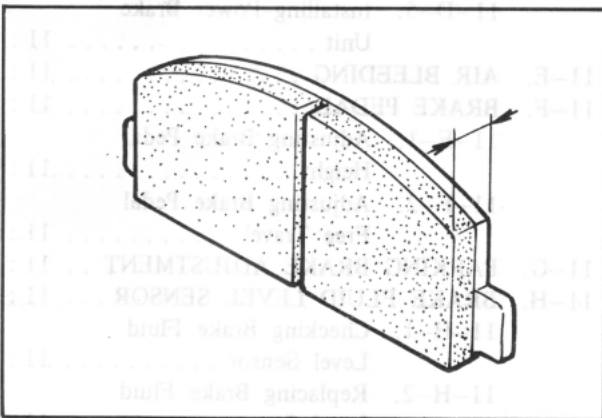

Fig. 11-3

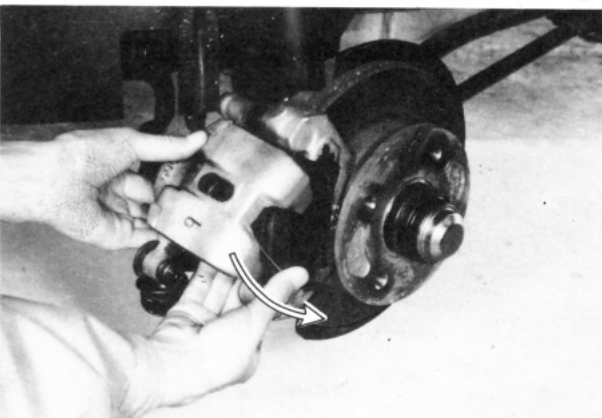

Fig. 11-4

11-A. FRONT BRAKE

11-A-1. Removing Disc Brake Pads

1. Raise the front end of the vehicle and support it with stands.
2. Remove the front wheel.
3. Remove the caliper attaching bolt (lower side).
4. Lift up the lower side of the caliper.

5. Remove the anti-rattle spring.
6. Remove the disc brake pads and the shims.

11-A-2. Checking Disc Brake Pads

Measure the thickness of the shoe and lining. If it exceeds limit, replace the disc brake pad with a new one.

Thickness limit: 6 mm (0.236 in)

Note:

- a) When the disc brake pads are replaced, replace all pads on both wheels at the same time.
- b) Do not mix different types of pads when replacing.

11-A-3. Installing Disc Brake Pads

Install the disc brake pads in the reverse order of removing.

Note:

When installing the caliper, coat the grease that contained in a brake pad kit or 8175 49 248 onto the caliper mounting pins.

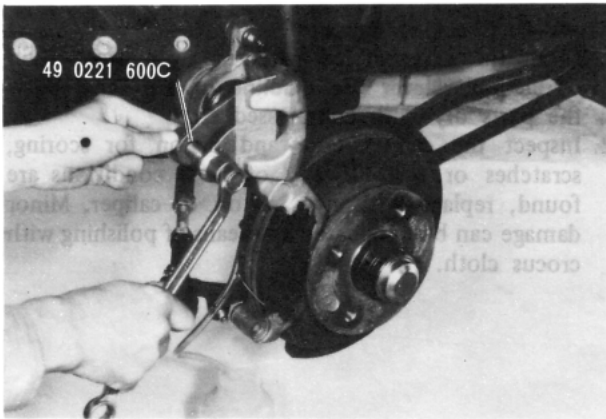

Fig. 11-5

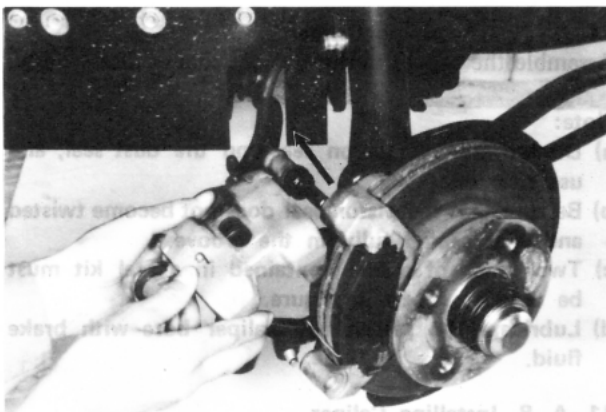

Fig. 11-6



Fig. 11-7



Fig. 11-8

If it is difficult to install the caliper, conduct the followings.

1. Remove the rubber cap from the bleeder screw and attach a vinyl tube to the bleeder screw. Submerge the other end of the vinyl tube into a suitable container.
2. Loosen the bleeder screw and press the piston into the cylinder with the **expand tool** (49 0221 600C).
3. Tighten the bleeder screw and remove the vinyl tube and expand tool.
4. Install the caliper.

11-A-4. Removing Caliper

1. Raise the front end of the vehicle and support it with stands.
2. Remove the front wheel.
3. Temporarily loosen the brake flexible hose at the caliper.
4. Remove the caliper attaching bolt (lower side) and lift up the caliper.
5. Slide out the caliper toward the inside of the vehicle and remove the caliper.
6. Disconnect the flexible hose from the caliper and plug the end of the flexible hose.

11-A-5. Disassembling Caliper

1. Clean the out side of the caliper.
2. Remove the dust boot retainer and dust boot.
3. Remove the piston.
Place a hard wood in the caliper pit and gradually blow compressed air from the fluid hole.

Note:

If it is difficult to remove the piston, lightly tap around the piston while applying air pressure.

4. Remove the piston seal by using the suitable tool.
5. Remove the bleeder cap and screw.

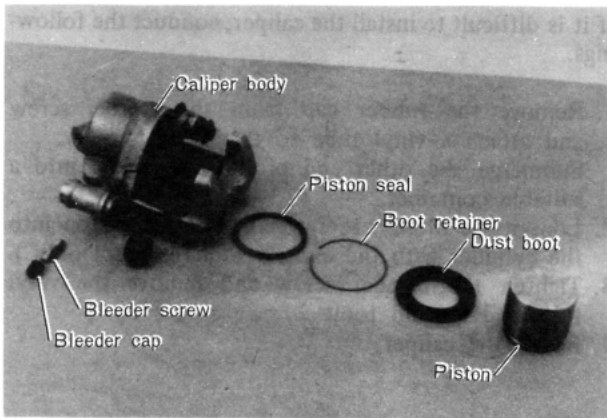

Fig. 11-9

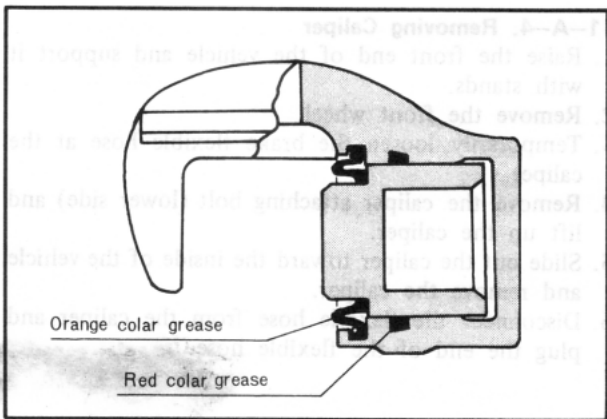

Fig. 11-10

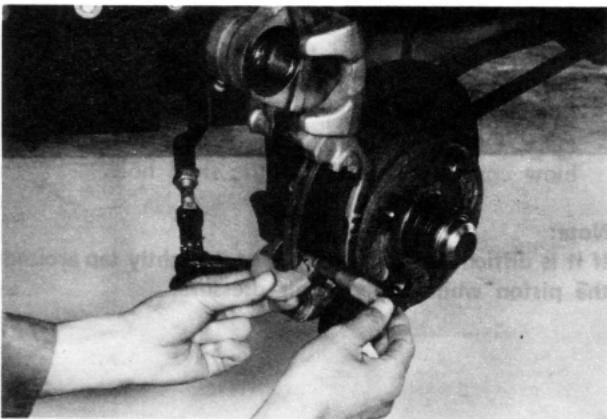

Fig. 11-11

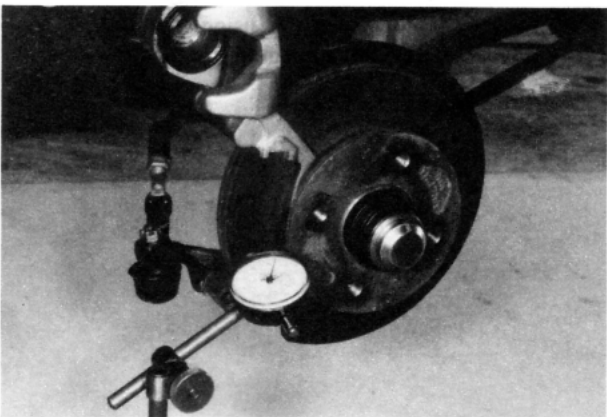

Fig. 11-12

11-A-6. Checking Caliper

1. Clean the disassembled parts in clean brake fluid or alcohol. **Never use gasoline or kerosene.** Blow the parts dry with compressed air.
2. Inspect the caliper bore and piston for scoring, scratches or rust. If any of these conditions are found, replace with new piston or caliper. Minor damage can be eliminated by means of polishing with crocus cloth.

11-A-7. Assembling Caliper

Assemble the caliper in the reverse order of disassembly.

Note:

- a) Discard the old piston seal and the dust seal, and use new ones.
- b) Be sure that the piston seal does not become twisted and it is seated fully in the groove.
- c) Two kinds of grease contained in a seal kit must be used as shown in figure.
- d) Lubricate the piston and caliper bore with brake fluid.

11-A-8. Installing Caliper

Install the caliper in the reverse order of removing and bleed the hydraulic system referring to Par. 11-E.

11-A-9. Checking Brake Disc

1. Remove the disc brake pads and caliper as described in Par. 11-A-1.
2. Inspect the surface of the disc for scoring, scratches, rust and excessive wear. Reface the disc as necessary.

Brake disc thickness:

Standard 18 mm (0.7087 in)

Thickness limit 17 mm (0.6693 in)

3. Check the lateral run-out of the disc with a dial indicator.

Run-out limit: 0.1 mm (0.0039 in)

Note:

Make certain that the wheel bearing preload is correctly adjusted, before checking the run-out of the disc.

11-A-10. Replacing Brake Disc

To remove or replace the brake disc and wheel hub assembly, refer to Par. 12-E-2.

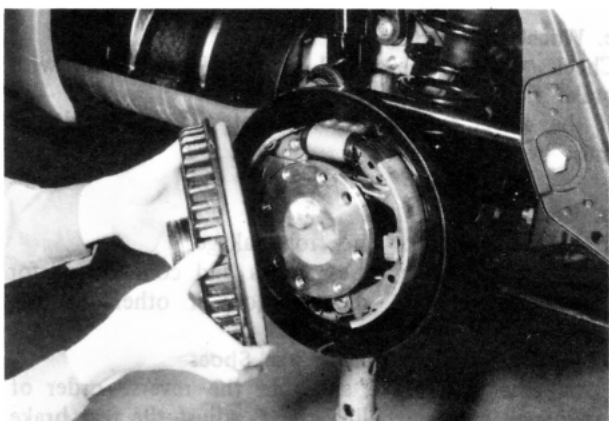

Fig. 11-13

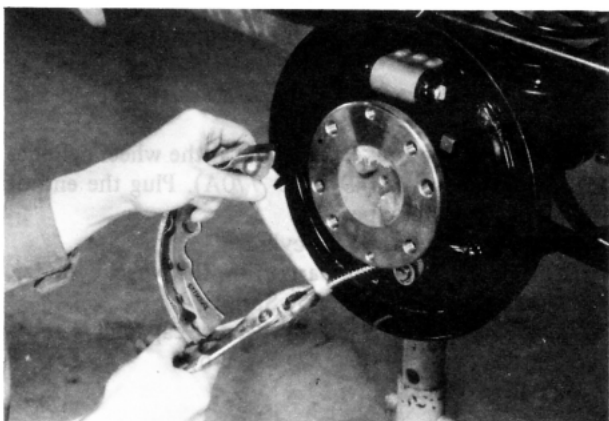

Fig. 11-14

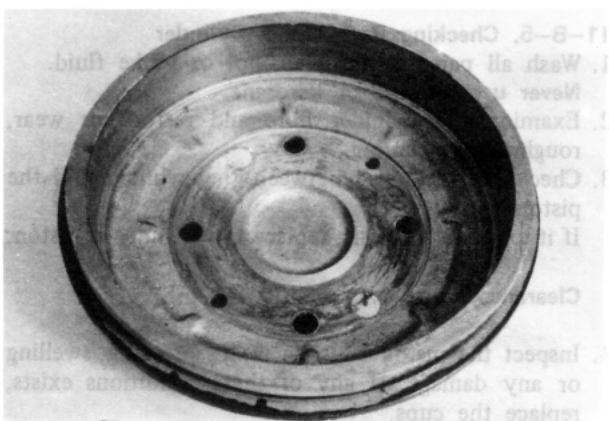

Fig. 11-15

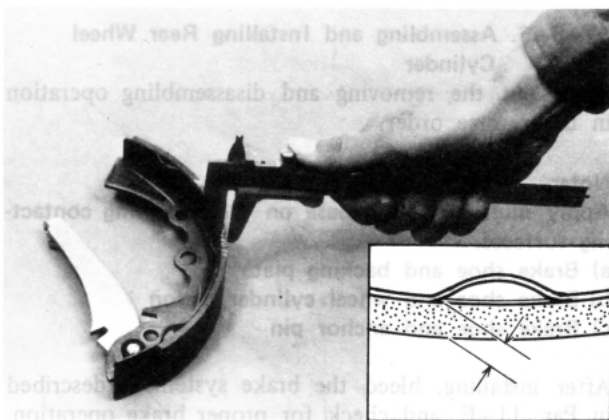

Fig. 11-16

11-B. REAR BRAKE

11-B-1. Removing Rear Brake Shoes

1. Raise the rear end of the vehicle and support the rear axle housing with stands.
2. Remove the rear wheel.
3. Remove the brake drum attaching screws.
4. Fully release the parking brake and remove the brake drum.

5. Remove the return springs and parking brake strut rod.
6. Remove the brake shoe retaining springs and guide pins.
7. Remove the brake shoes.
8. Remove the parking brake cable from the operating lever on the brake shoe.

11-B-2. Inspecting Rear Brake

Check the following parts and repair or replace any part if found defective.

a. Brake drum

Inspect the brake drum for damage, wear and scores.

Roughness limit: 0.15 mm (0.006 in)

**Drum inner diameter limit:
201 mm (7.9135 in)**

**Standard diameter:
200 mm (7.8741 in)**

b. Brake linings

Inspect the brake lining for wear, damage and deformation.

**Lining thickness:
Limit 1.0 mm (0.039 in)
Standard 4.0 mm (0.1575 in)**

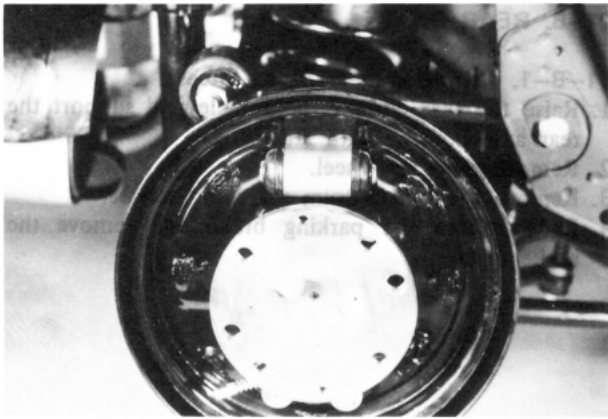

Fig. 11-17

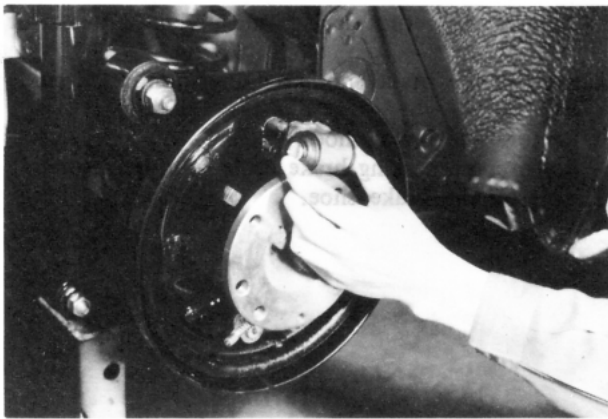

Fig. 11-18

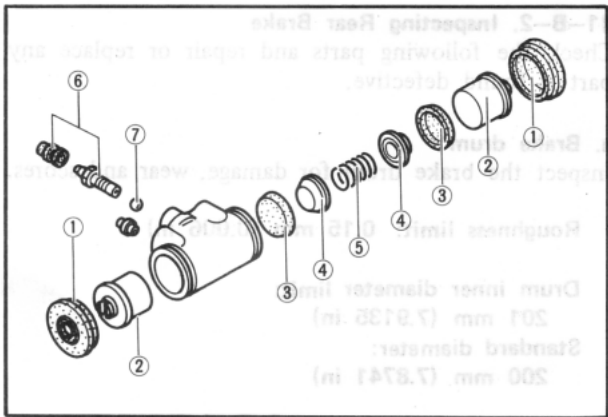

Fig. 11-19

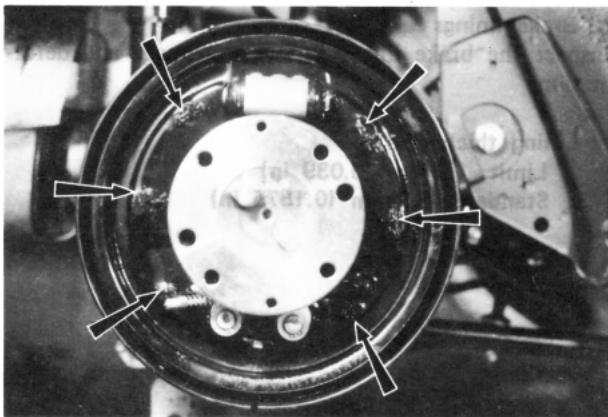

Fig. 11-20

c. Wheel cylinders

Check whether the wheel cylinder boot is wet with brake fluid.

If the wheel cylinder boot is wet, the wheel cylinder must be overhauled.

d. Brake lines

1. Inspect all brake lines for leakage.
2. Check all brake pipes, hoses and connections for signs of chafing, deterioration or other damage.

11-B-3. Installing Rear Brake Shoes

Install the rear brake shoes in the reverse order of removing. After installing them, adjust the rear brake as described in Par. 11-B-7.

11-B-4. Removing and Disassembling Rear Wheel Cylinder

1. Remove the rear brake shoes, as described in Par. 11-B-1.
2. Disconnect the brake fluid pipe at the wheel cylinder using the **spanner** (49 0259 770A). Plug the end of the brake fluid pipe.
3. Remove the rear wheel cylinder.
4. Remove the following parts from the wheel cylinder.

1) Dust boots	5) Spring
2) Pistons	6) Bleeder cap and screw
3) Piston cups	7) Steel ball
4) Filling blocks	

11-B-5. Checking Rear Wheel Cylinder

1. Wash all parts in clean alcohol or brake fluid. **Never use gasoline or kerosene.**
2. Examine the cylinder bore and piston for wear, roughness or scoring.
3. Check the clearance between the cylinder and the piston. If it exceeds the limit, replace the cylinder or piston.

Clearance limit: 0.15 mm (0.006 in)

4. Inspect the piston cups for wear, softening, swelling or any damage. If any of these conditions exists, replace the cups.

11-B-6. Assembling and Installing Rear Wheel Cylinder

Carry out the removing and disassembling operation in the reverse order.

Note:

Apply multi-purpose grease on the following contact surfaces.

- a) Brake shoe and backing plate
- b) Brake shoe and wheel cylinder piston
- c) Brake shoe and anchor pin

After installing, bleed the brake system as described in Par. 11-E, and check for proper brake operation.

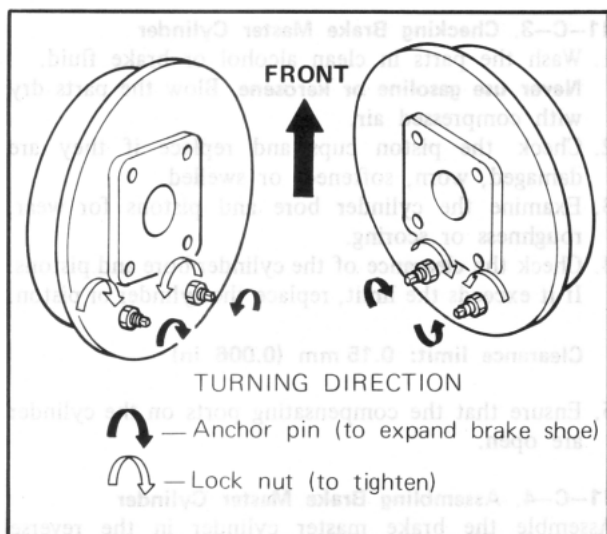

Fig. 11-21

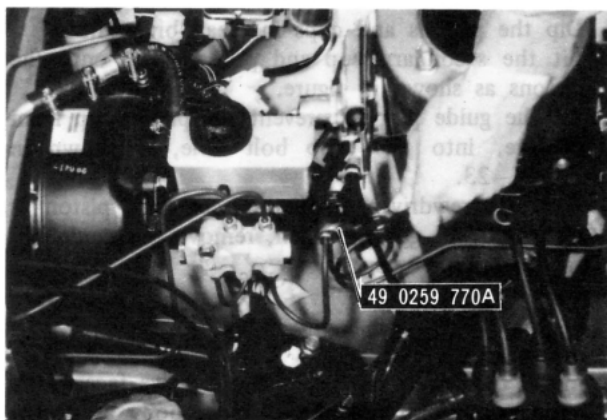

Fig. 11-22

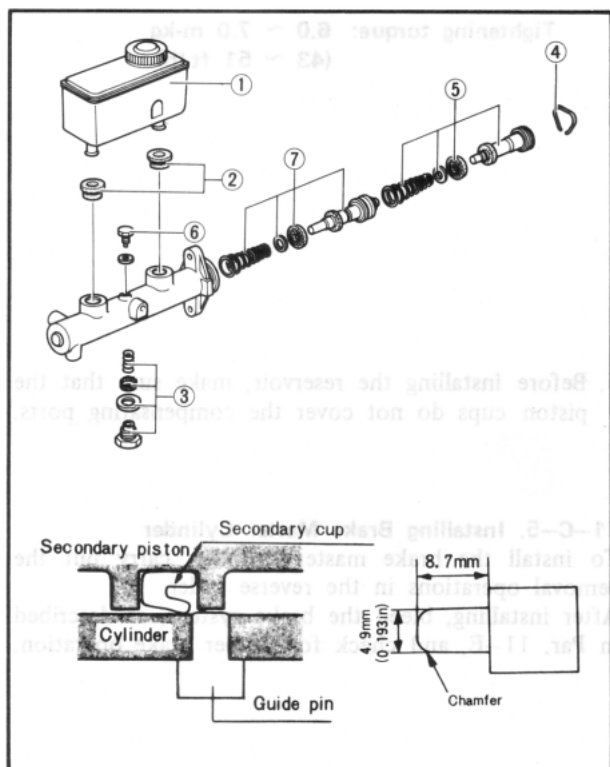

Fig. 11-23

11-B-7. Adjusting Rear Brake

1. Raise the rear end of the vehicle until the wheels are free to turn and support it with stands.
2. Release the parking brake fully.
3. Loosen the anchor pin lock nut.
4. Hold the lock nut and turn the anchor pin in the allow direction until the wheel is locked.
5. Back off the anchor pin until the wheel just turns freely.
6. Hold the anchor pin in position and tighten the lock nut.
7. Repeat the above procedure on the other side brake shoes.
8. Lower the vehicle.

11-C. BRAKE MASTER CYLINDER

11-C-1. Removing Brake Master Cylinder

1. Disconnect the oil level sensor coupler.
2. Disconnect the fluid pipes at the master cylinder outlets using the **spanner** (49 0259 770A).
3. Remove the proportioning by-pass valve attaching bolt.
4. Remove the brake master cylinder assembly.

Note:

Never allow the brake fluid to drop on any painted surface.

11-C-2. Disassembling Brake Master Cylinder

After draining the brake fluid, remove the following parts.

- 1) Reservoir
- 2) Bushes
- 3) Joint bolt, check valve and spring
- 4) Stop ring
- 5) Primary piston assembly and spring
- 6) Secondary piston stop bolt and washer
- 7) Secondary piston assembly and spring

To remove the secondary piston;

Push in the secondary piston with a screwdriver and then, remove the stop bolt and insert the guide pin in its place to prevent the piston cup from damage.

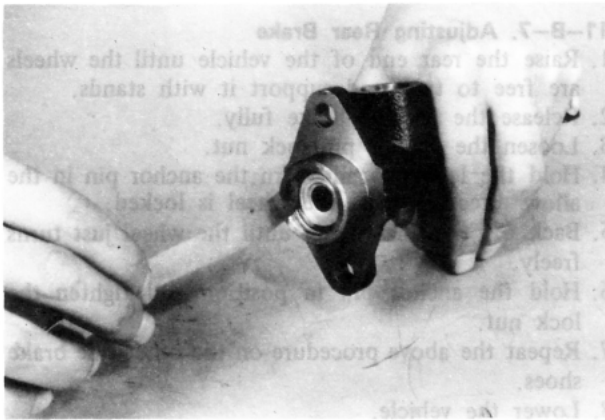

Fig. 11-24

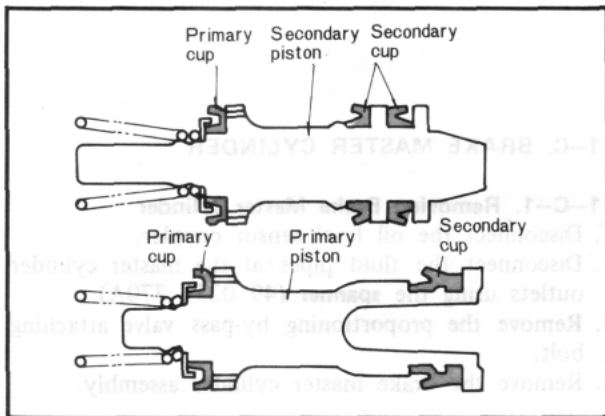

Fig. 11-25



Fig. 11-26

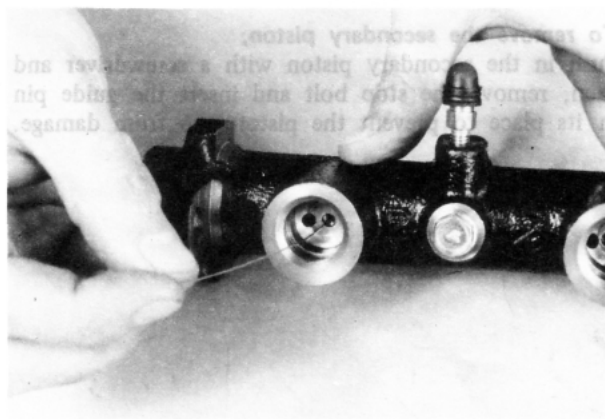

Fig. 11-27

11-C-3. Checking Brake Master Cylinder

1. Wash the parts in clean alcohol or brake fluid. **Never use gasoline or kerosene.** Blow the parts dry with compressed air.
2. Check the piston cups and replace if they are damaged, worn, softened, or swelled.
3. Examine the cylinder bore and pistons for wear, roughness or scoring.
4. Check the clearance of the cylinder bore and pistons. If it exceeds the limit, replace the cylinder or piston.

Clearance limit: 0.15 mm (0.006 in)

5. Ensure that the compensating ports on the cylinder are open.

11-C-4. Assembling Brake Master Cylinder

Assemble the brake master cylinder in the reverse order of disassembly, **noting** the following points.

1. Dip the pistons and cups in clean brake fluid.
2. Fit the secondary cup and primary cup onto the pistons as shown in figure.
3. Fit the guide pin, to prevent the piston cup from damage, into the stop bolt hole, as shown in Fig. 11-23. With a screwdriver, push the secondary piston as far as it will go, and then, remove the guide pin and install the stop ring.
4. Install the check valve so that the valve face which has six holes directs the cylinder body as shown in figure and tighten the joint bolt.

**Tightening torque: 6.0 ~ 7.0 m-kg
(43 ~ 51 ft-lb)**

5. Before installing the reservoir, make sure that the piston cups do not cover the compensating ports.

11-C-5. Installing Brake Master Cylinder

To install the brake master cylinder, carry out the removal operations in the reverse order. After installing, bleed the brake system, as described in Par. 11-E, and check for proper brake operation.

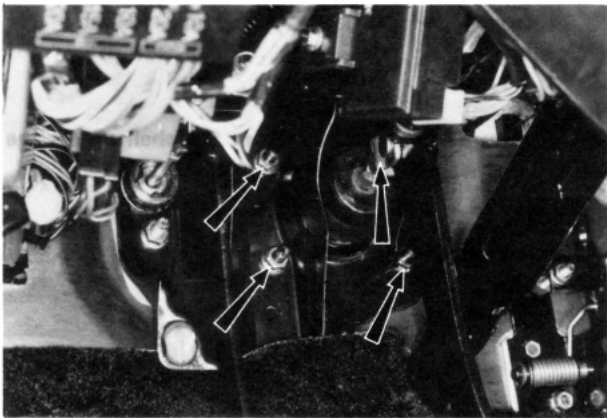

Fig. 11-28

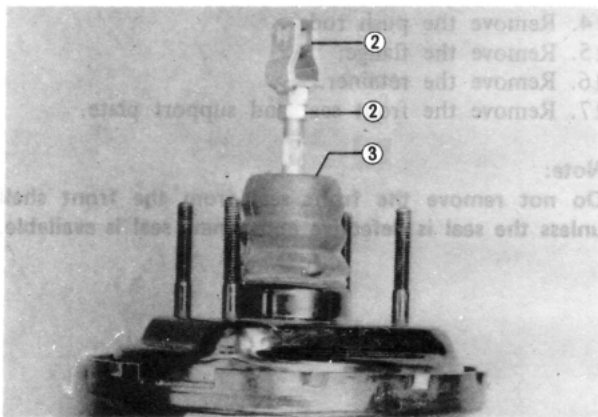

Fig. 11-29

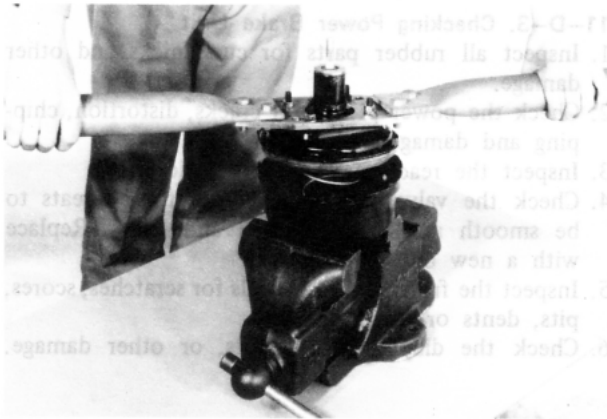

Fig. 11-30

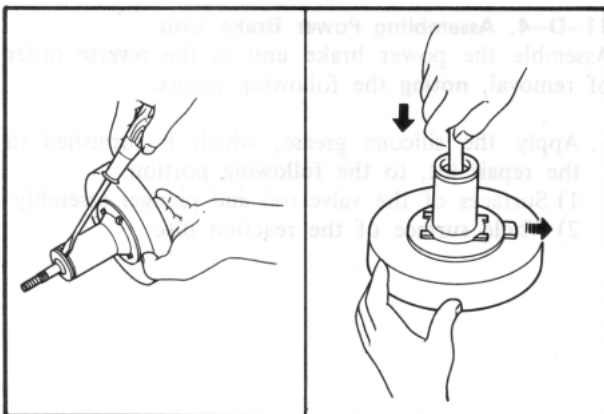

Fig. 11-31

11-D. POWER BRAKE UNIT

11-D-1. Removing Power Brake Unit

1. Remove the brake master cylinder, as described in Par. 11-C-1.
2. Disconnect the vacuum hose at the power brake unit.
3. Disconnect the push rod fork from the brake pedal.
4. Remove the power brake unit.

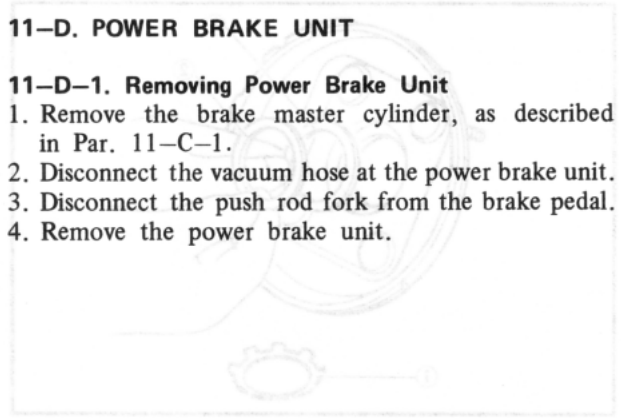

Fig. 11-27

11-D-2. Disassembling Power Brake Unit

1. Apply mating marks on the rear shell and front shell to facilitate reassembly.
2. Remove the fork end and lock nut.
3. Remove the dust boot.

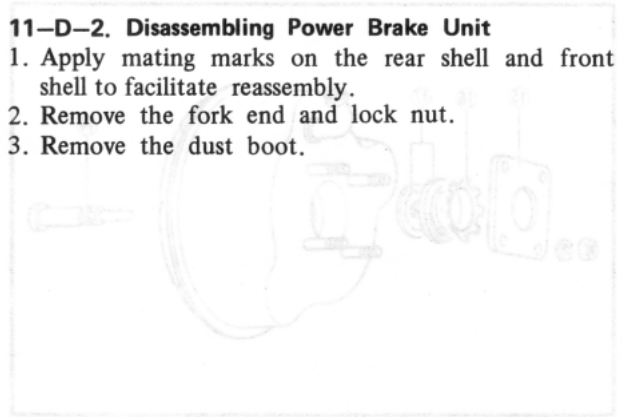

Fig. 11-28

4. Remove the rear shell assembly.
Attach the suitable wrench to the studs of the rear shell. Press down the rear shell and rotate the rear shell clockwise to unlocked position.

Note:

Loosen the rear shell carefully as it is spring-loaded.

5. Remove the spring.

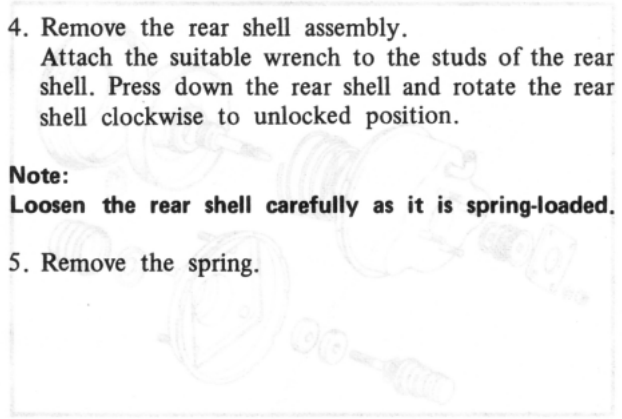

Fig. 11-29

6. Remove the air silencer retainer.
7. Remove the power piston, valve rod and plunger assembly from the rear shell.
8. Remove the diaphragm.
9. Press in the valve rod and remove the valve retainer key.
10. Remove the valve rod and plunger assembly.
11. Remove the air silencer and filter.

Note:

The valve rod and plunger are serviced as an assembly only.

12. Remove the reaction disc.

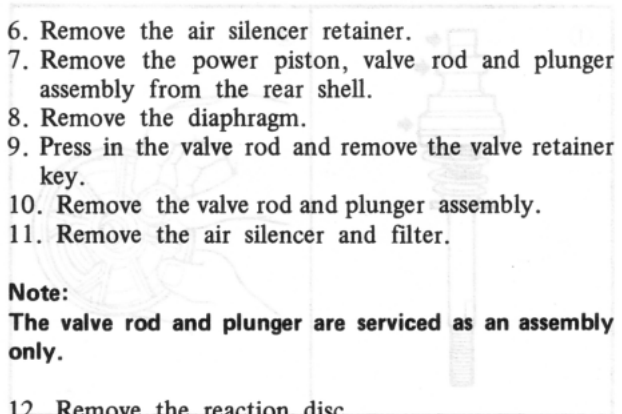

Fig. 11-30

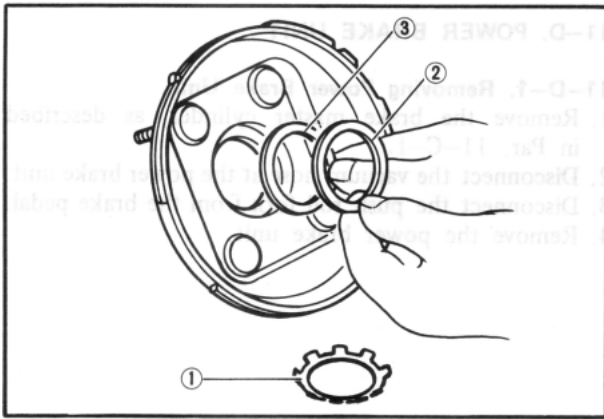

Fig. 11-32

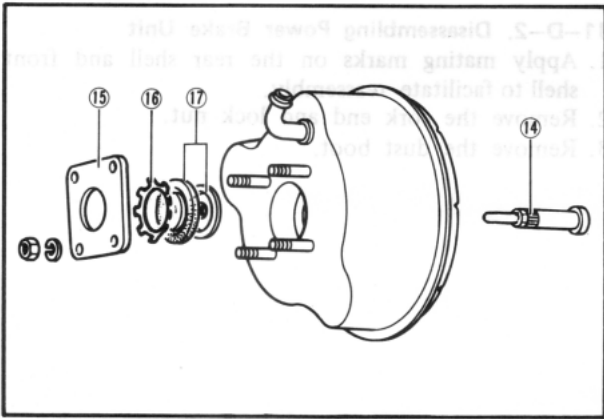

Fig. 11-33

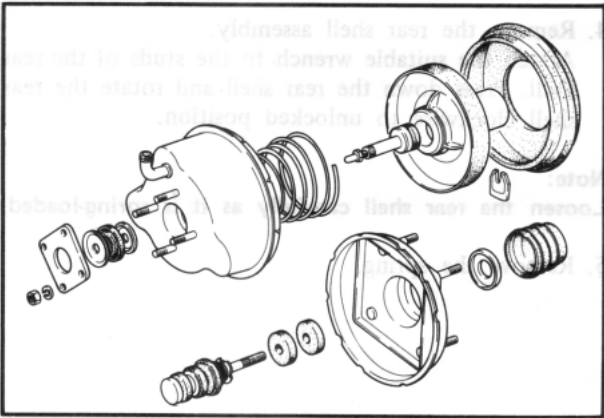

Fig. 11-34

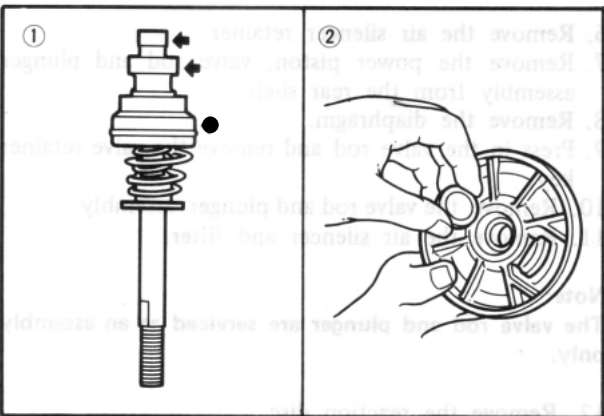

Fig. 11-35

13. Remove the retainer (1), bearing (2) and rear seal (3).

Note:

Do not remove the rear seal from the shell unless the seal is defective and a new seal is available.

14. Remove the push rod.

15. Remove the flange.

16. Remove the retainer.

17. Remove the front seal and support plate.

Note:

Do not remove the front seal from the front shell unless the seal is defective and a new seal is available.

11-D-3. Checking Power Brake Unit

1. Inspect all rubber parts for cuts, nicks and other damage.
2. Check the power piston for cracks, distortion, chipping and damaged seats.
3. Inspect the reaction disc for deterioration.
4. Check the valve rod and plunger for all seats to be smooth and free of nicks and dents. Replace with a new one if defective.
5. Inspect the front and rear shells for scratches, scores, pits, dents or other damage.
6. Check the diaphragm for cuts, or other damage.

11-D-4. Assembling Power Brake Unit

Assemble the power brake unit in the reverse order of removal, **noting** the following points.

1. Apply the silicone grease, which is furnished in the repair kit, to the following portion.
 - 1) Surfaces of the valve rod and plunger assembly
 - 2) Whole surface of the reaction disc

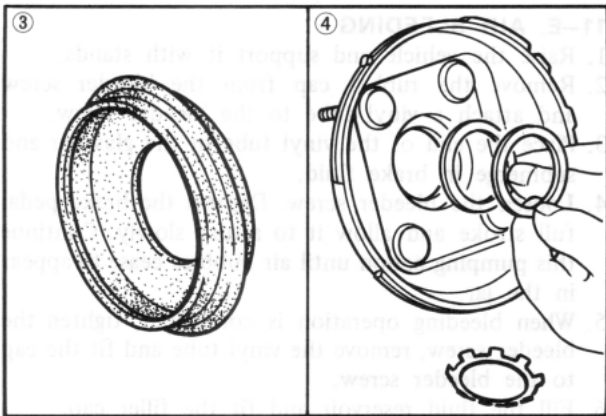

Fig. 11-36

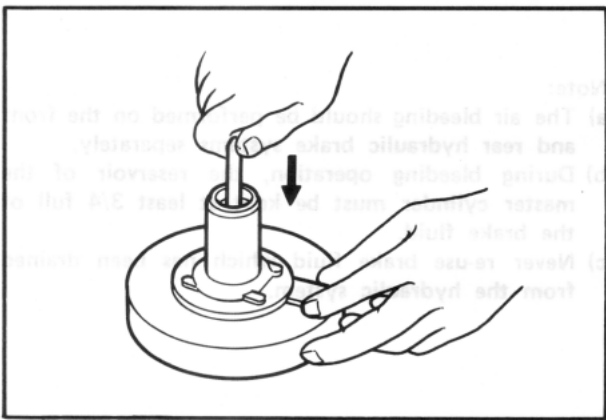

Fig. 11-37

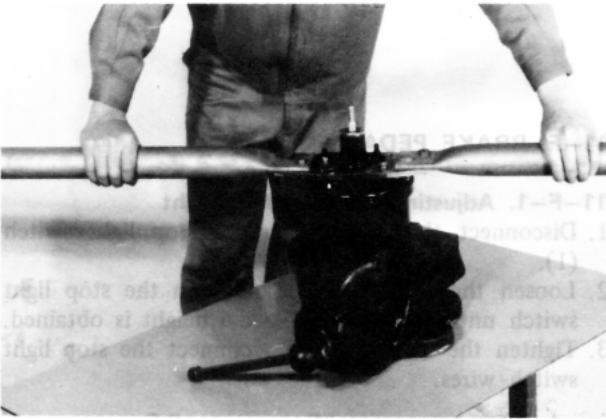

Fig. 11-38

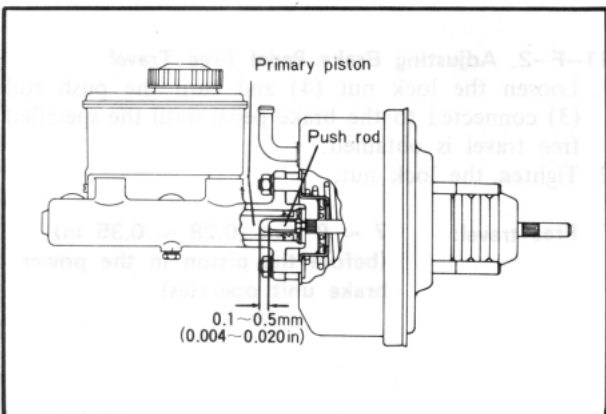

Fig. 11-39

- 3) Outer bead of the diaphragm
- 4) Front and rear seal lips

2. To install the valve retainer key, press down the valve rod and align the groove on the valve rod with the slot of the power piston.

3. Install the rear shell assembly onto the front shell by using the wrench to rotate the rear shell counterclockwise until mating marks aligned.

Note:

Press the rear shell down firmly, maintaining a pressure until the shell flanges are fully locked.

11-D-5. Installing Power Brake Unit

Install the power brake unit in the reverse order of removal.

Note:

Before installing the power brake unit, adjust the push rod length so that the proper clearance between the primary piston and the push rod is obtained.

Standard clearance:

0.1 ~ 0.5 mm (0.004 ~ 0.020 in)

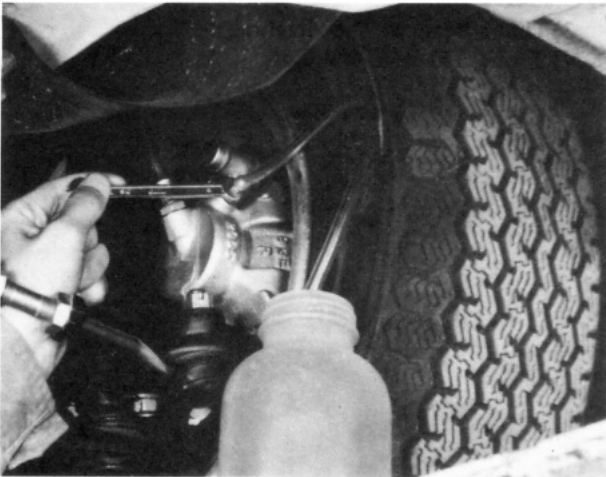

Fig. 11-40

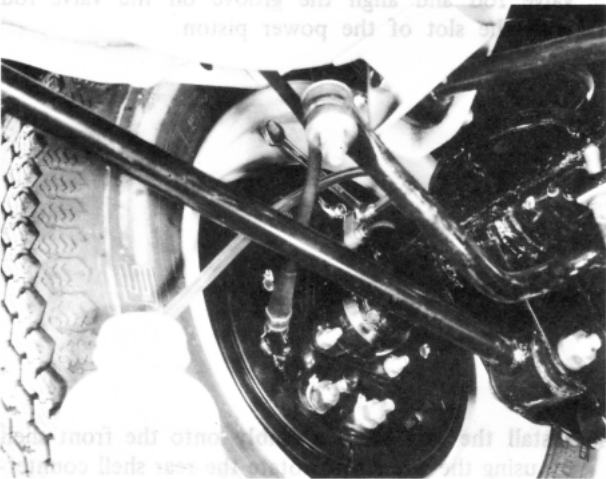

Fig. 11-41

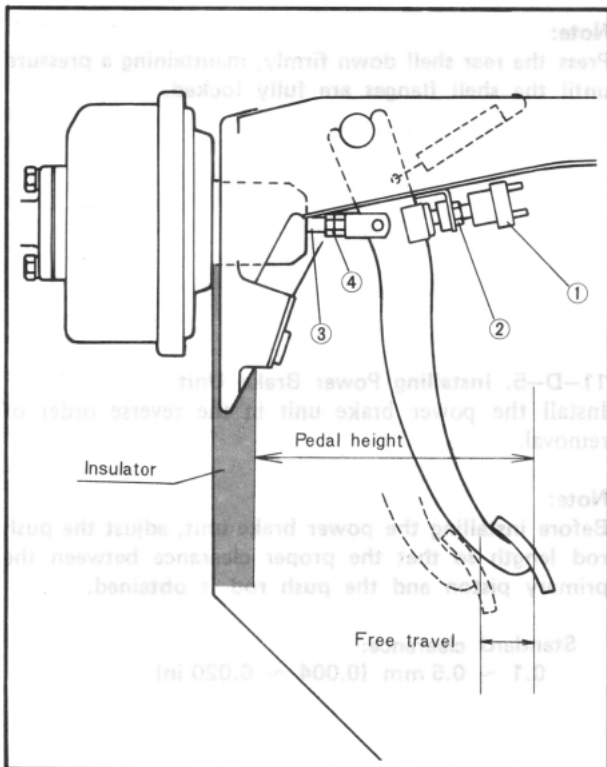

Fig. 11-42

11-E. AIR BLEEDING

1. Raise the vehicle and support it with stands.
2. Remove the rubber cap from the bleeder screw and attach a vinyl tube to the bleeder screw.
3. Place the end of the vinyl tube in the glass jar and submerge in brake fluid.
4. Loosen the bleeder screw. Depress the brake pedal full stroke and allow it to return slowly. Continue this pumping action until air bubbles cease to appear in the jar.
5. When bleeding operation is completed, tighten the bleeder screw, remove the vinyl tube and fit the cap to the bleeder screw.
6. Fill the fluid reservoir and fit the filler cap.

Note:

- a) The air bleeding should be performed on the front and rear hydraulic brake systems separately.
- b) During bleeding operation, the reservoir of the master cylinder must be kept at least 3/4 full of the brake fluid.
- c) Never re-use brake fluid which has been drained from the hydraulic system.

11-F. BRAKE PEDAL

11-F-1. Adjusting Brake Pedal Height

1. Disconnect the wires from the stop light switch (1).
2. Loosen the lock nut (2) and turn the stop light switch until the specified pedal height is obtained.
3. Tighten the lock nut and reconnect the stop light switch wires.

Pedal height: $190 \begin{smallmatrix} +5 \\ -0 \end{smallmatrix} \text{ mm } (7.5 \begin{smallmatrix} +0.2 \\ -0 \end{smallmatrix} \text{ in})$

11-F-2. Adjusting Brake Pedal Free Travel

1. Loosen the lock nut (4) and turn the push rod (3) connected to the brake pedal until the specified free travel is obtained.
2. Tighten the lock nut.

Free travel: $7 \sim 9 \text{ mm } (0.28 \sim 0.35 \text{ in})$
(before the piston in the power brake unit operates)



Fig. 11-43

11-G. PARKING BRAKE ADJUSTMENT

When the parking brake requires adjustment, proceed as follows.

1. Make sure that the parking brake is fully released.
2. Jack up the rear end of the vehicle until the wheels are free to turn. Then, support it with stands.
3. Adjust the parking brake lever adjusting screw so that the rear brakes are locked at **3 ~ 7 notches** when the parking brake lever is pulled by approx. **10 kg (22 lb)** of force.
4. After adjustment is completed, apply the parking brake several times, then, release and make sure that the rear wheels rotate freely without dragging.
5. Lower the vehicle.
6. Adjust the parking brake warning light switch so that the light comes on with the parking brake lever pulled out 1 notch and turns off when the lever is fully released.

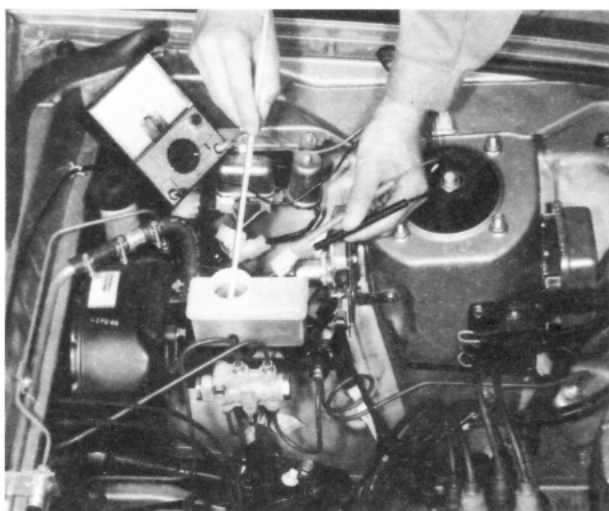

Fig. 11-44

11-H. BRAKE FLUID LEVEL SENSOR

11-H-1. Checking Brake Fluid Level Sensor

1. Disconnect the coupler of the sensor.
2. Connect a circuit tester to the coupler and check the continuity by moving the float up and down. When the float is below "MIN" mark, the tester should show a continuity while the tester should not show any continuity when the float is above "MIN" mark. If it is found not to be so, replace the fluid level sensor.

11-H-2. Replacing Brake Fluid Level Sensor

1. Disconnect the coupler of the sensor.
2. Pull out the fluid sensor from the reservoir.
3. Install a new fluid level sensor and connect the coupler.

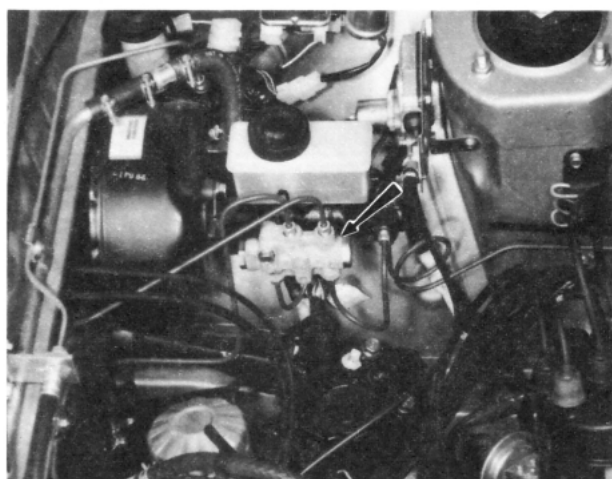

Fig. 11-45

11-I. PROPORTIONING BYPASS VALVE

To replace the proportioning bypass valve, proceed as follows.

1. Disconnect the fluid pipes at the proportioning bypass valve.
2. Remove the proportioning bypass valve.
3. Install the new proportioning bypass valve.
4. Connect the fluid pipes to the proportioning bypass valve, noting the identification markd on the valve body.
5. Bleed the brake system, as described in Par. 11-E.

Note:

Never allow the brake fluid to drop on any painted surface.

11-J. HYDRAULIC LINES INSPECTION

Inspect all brake lines for any leakage with the foot brakes applied.

Check all brake pipes, hoses and connections for signs of chafing, deterioration or any other damage.